



**Thienes Engineering, Inc.**  
CIVIL ENGINEERING • LAND SURVEYING

# Preliminary Water Quality Management Plan (PWQMP)

For:

**Yorba Avenue Industrial Development**  
**13610 Yorba Avenue**  
**Chino, CA 91710**  
**PL 23-0034**

APNs: 1019-501-01 and 1019-511-07

**Prepared for:**

CRP/Lovett Chino Industrial Owner, L.L.C.  
610 Newport Center Drive, Suite 340  
Newport Beach, CA 92660  
Phone: (949) 402-2760  
Contact: Tyler Banton

**Prepared by:**

Thienes Engineering, Inc.  
14349 Firestone Boulevard  
La Mirada, CA 90638  
Phone: (714) 521-4811  
Contact: Luis Prado (luisp@thieneseng.com)  
Job No. 4163

Approval Date: \_\_\_\_\_

Implementation Date: \_\_\_\_\_

1<sup>st</sup> Submittal: July 24, 2023  
2<sup>nd</sup> Submittal: September 7, 2023  
3<sup>rd</sup> Submittal: October 18, 2023  
4<sup>th</sup> Submittal: April 23, 2024

## Project Owner's Certification

This Water Quality Management Plan (WQMP) has been prepared for **CRP/Lovett Chino Industrial Owner, L.L.C.** by **Thienes Engineering, Inc.** The WQMP is intended to comply with the requirements of the **City of Chino** and the NPDES Areawide Stormwater Program requiring the preparation of a WQMP.

The undersigned, while it owns the subject property, is responsible for the implementation of the provisions of this plan and will ensure that this plan is amended as appropriate to reflect up-to-date conditions on the site consistent with the San Bernardino County's Municipal Storm Water Management Program and the intent of the NPDES Permit for San Bernardino County and the incorporated cities of San Bernardino County within the Santa Ana Region. Once the undersigned transfers its interest in the property, its successors in interest and the city/county shall be notified of the transfer. The new owner will be informed of its responsibility under this WQMP. A copy of the approved WQMP shall be available on the subject site in perpetuity.

"I certify under a penalty of law that the provisions (implementation, operation, maintenance, and fund) of the WQMP have been accepted and that the plan will be transferred to future successors."

Project Data			
Permit/Application Number(s):	PL 23-0034	Grading Permit Number(s):	
Tract/Parcel Map Number(s):		Building Permit Number(s):	
CUP, SUP, and/or APN (Specify Lot Numbers if Portions of Tract):			APNs: 1019-501-01 and 1019-511-07
Owner's Signature			
<b>Owner Name: CRP/Lovett Chino Industrial Owner, L.L.C.</b>			
Name/Title	Tyler Banton / Director, Southern California		
Company	CRP/Lovett Chino Industrial Owner, L.L.C.		
Address	610 Newport Center Drive, Suite 340, Newport Beach, CA 92660		
Email	Tyler.Banton@Lovettindustrial.com		
Telephone #	(949) 402-2760		
Signature		Date	

## Preparer's Certification

Project Data			
Permit/Application Number(s):	PL 23-0034	Grading Permit Number(s):	
Tract/Parcel Map Number(s):		Building Permit Number(s):	
CUP, SUP, and/or APN (Specify Lot Numbers if Portions of Tract):			APNs: 1019-501-01 and 1019-511-07

“The selection, sizing and design of stormwater treatment and other stormwater quality and quantity control measures in this plan were prepared under my oversight and meet the requirements of Regional Water Quality Control Board Order No. R8-2010-0036.”

<b>Engineer: Reinhard Stenzel</b>		<p><b>PE Stamp Below</b></p> 
Title	Director of Engineering	
Company	Thienes Engineering, Inc.	
Address	14349 Firestone Boulevard, La Mirada, CA 90638	
Email	reinhard@thieneseng.com	
Telephone #	(714) 521-4811	
Signature		

# Contents

Section 1	Discretionary Permit(s).....	1-1
Section 2	Project Description .....	2-1
2.1	Project Information .....	2-1
2.2	Property Ownership/Management .....	2-2
2.3	Potential Stormwater Pollutants .....	2-2
2.4	Water Quality Credits .....	2-3
Section 3	Site and Watershed Description .....	3-1
Section 4	Best Management Practices (BMP) .....	4-1
4.1	Source Control BMP .....	4-1
4.1.1	Pollution Prevention .....	4-1
4.1.2	Preventive LID Site Design Practices.....	4-6
4.2	Project Performance Criteria.....	4-7
4.3	Project Conformance Analysis.....	4-12
4.3.1	Site Design Hydrologic Source Control BMP.....	4-14
4.3.2	Infiltration BMPs.....	4-16
4.3.3	Harvest and Use BMP .....	4-18
4.3.4	Biotreatment BMP.....	4-19
4.3.5	Conformance Summary.....	4-23
4.3.6	Hydromodification Control BMP .....	4-24
4.4	Alternative Compliance Plan (if applicable).....	4-25
Section 5	Inspection and Maintenance Responsibility for Post Construction BMP .....	5-1
Section 6	WQMP Attachments.....	6-1
6.1	Site Plan and Drainage Plan.....	6-1
6.2	Electronic Data Submittal .....	6-2
6.3	Post Construction .....	6-3
6.4	Other Supporting Documentation.....	6-4

## Forms

Form 1-1 Project Information.....	1-1
Form 2.1-1 Description of Proposed Project.....	2-1
Form 2.2-1 Property Ownership/Management .....	2-2
Form 2.3-1 Pollutants of Concern .....	2-2
Form 2.4-1 Water Quality Credits .....	2-3
Form 3-1 Site Location and Hydrologic Features .....	3-1
Form 3-2 Existing Hydrologic Characteristics for Drainage Area (DA).....	3-2
Form 3-3 Watershed Description .....	3-3
Form 4.1-1 Non-Structural Source Control BMPs .....	4-2
Form 4.1-2 Structural Source Control BMPs .....	4-4
Form 4.1-3 Preventive LID Site Design Practices Checklist.....	4-6
Form 4.2-1 LID BMP Performance Criteria for Design Capture Volume (DMA 1) .....	4-7
Form 4.2-2 Summary of HCOC Assessment.....	4-8
Form 4.2-3 HCOC Assessment for Runoff Volume .....	4-9
Form 4.2-4 HCOC Assessment for Time of Concentration .....	4-10
Form 4.2-5 HCOC Assessment for Peak Runoff .....	4-11
Form 4.3-1 Infiltration BMP Feasibility (DMA 1) .....	4-13
Form 4.3-2 Site Design Hydrologic Source Control BMPs .....	4-15
Form 4.3-3 Infiltration LID BMP (including underground BMPs) (DMA 1) .....	4-17
Form 4.3-4 Harvest and Use BMPs.....	4-18
Form 4.3-5 Selection and Evaluation of Biotreatment BMP .....	4-19
Form 4.3-6 Volume Based Biotreatment – Bioretention and Planter Boxes with Underdrains.....	4-20
Form 4.3-7 Volume Based Biotreatment – Constructed Wetlands and Extended Detention.....	4-21
Form 4.3-8 Flow Based Biotreatment .....	4-22
Form 4.3-9 Conformance Summary and Alternative Compliance Volume Estimate (DMA 1) .....	4-23
Form 4.3-10 Hydromodification Control BMPs .....	4-24
Form 5-1 BMP Inspection and Maintenance.....	5-1

## Attachments

- Attachment A: Existing Condition Site Photos
- Attachment B: BMP Design Calculations & Supporting Documentation
- Attachment C: WQMP Site Map
- Attachment D: WQMP and Stormwater BMP Transfer, Access and Maintenance Agreement
- Attachment E: Educational Materials
- Attachment F: Infiltration Report
- Attachment G: HCOC

## Section 1 Discretionary Permit(s)

<b>Form 1-1 Project Information</b>					
<b>Project Name</b>		Yorba Avenue Industrial Development			
<b>Project Owner Contact Name:</b>		Tyler Banton			
<b>Mailing Address:</b>	610 Newport Center Drive, Suite 340 Newport Beach, CA 92660	<b>E-mail Address:</b>	tyler.banton@lovetindustrial.com	<b>Telephone:</b>	(949) 402-2760
<b>Permit/Application Number(s):</b>		PL 23-0034	<b>Tract/Parcel Map Number(s):</b>		
<b>Additional Information/Comments:</b>		n/a			
<b>Description of Project:</b>	<p>The project site encompasses approximately 13.51 acres. Proposed improvements to the site consist of the construction of one warehouse type building of approximately 298,839 square feet. A truck yard will be located west of the building. Vehicle parking lots will be located along the east and west sides of the building. Landscaping will be located throughout the site.</p> <p>Runoff from the easterly half of the building's rooftop and the easterly vehicle parking lot will surface drain to three grated inlets located in the parking lot. A proposed storm drain (LINE "B") will convey this runoff northerly, wrap around the building along the north side, then head southerly through the truck yard towards a proposed storm drain that captures and conveys offsite run-on from the northerly offsite area (LAT "A1").</p> <p>Runoff from the northerly drive aisle, the westerly half of the building's rooftop and the truck yard area will surface drain to six grated inlets before also draining to LINE "B" and then LAT "A1". LAT "A1" ultimately connects to a proposed public storm drain system in Schaefer Avenue.</p> <p>Runoff from the southerly vehicle parking lot will drain to one grated inlet located at the westerly end of the parking lot. A proposed storm drain (LAT "A-1a") will convey this runoff westerly into LAT "A1". LAT "A1" ultimately connects to a proposed public storm drain system in Schaefer Avenue.</p> <p>Infiltration type BMPs were deemed feasible in the truck yard area where infiltration rates ranged between 5.7 to 6.8 inches per hour. Before runoff is discharged offsite, the DCV will be diverted to the proposed underground infiltration chambers. Once the DCV is met, "high flows" will continue to drain offsite as mentioned above. A hydrodynamic separator will be utilized for pretreatment.</p> <p>Approximately 0.34 acres of landscaped areas (including some driveway areas) along Schaefer Avenue will drain offsite without being routed to the BMPs. The landscaped areas are considered self-treating areas.</p>				
<b>Provide summary of Conceptual WQMP conditions (if previously submitted and approved). Attach complete copy.</b>	<p>"Full trash capture" filters will be added to public catch basins on Yorba Avenue and Schaeffer Avenue to comply with the Statewide Trash Mandate.</p>				

## Section 2 Project Description

### 2.1 Project Information

This section of the WQMP should provide the information listed below. The information provided for Conceptual/ Preliminary WQMP should give sufficient detail to identify the major proposed site design and LID BMPs and other anticipated water quality features that impact site planning. Final Project WQMP must specifically identify all BMP incorporated into the final site design and provide other detailed information as described herein.

The purpose of this information is to help determine the applicable development category, pollutants of concern, watershed description, and long term maintenance responsibilities for the project, and any applicable water quality credits. This information will be used in conjunction with the information in Section 3, Site Description, to establish the performance criteria and to select the LID BMP or other BMP for the project or other alternative programs that the project will participate in, which are described in Section 4.

<b>Form 2.1-1 Description of Proposed Project</b>					
<b><sup>1</sup> Development Category (Select all that apply):</b>					
<input type="checkbox"/> Significant re-development involving the addition or replacement of 5,000 ft <sup>2</sup> or more of impervious surface on an already developed site	<input checked="" type="checkbox"/> New development involving the creation of 10,000 ft <sup>2</sup> or more of impervious surface collectively over entire site	<input type="checkbox"/> Automotive repair shops with standard industrial classification (SIC) codes 5013, 5014, 5541, 7532-7534, 7536-7539	<input type="checkbox"/> Restaurants (with SIC code 5812) where the land area of development is 5,000 ft <sup>2</sup> or more		
<input type="checkbox"/> Hillside developments of 5,000 ft <sup>2</sup> or more which are located on areas with known erosive soil conditions or where the natural slope is 25 percent or more	<input type="checkbox"/> Developments of 2,500 ft <sup>2</sup> of impervious surface or more adjacent to (within 200 ft) or discharging directly into environmentally sensitive areas or waterbodies listed on the CWA Section 303(d) list of impaired waters.	<input checked="" type="checkbox"/> Parking lots of 5,000 ft <sup>2</sup> or more exposed to storm water	<input type="checkbox"/> Retail gasoline outlets that are either 5,000 ft <sup>2</sup> or more, or have a projected average daily traffic of 100 or more vehicles per day		
<input type="checkbox"/> Non-Priority / Non-Category Project <i>May require source control LID BMPs and other LIP requirements. Please consult with local jurisdiction on specific requirements.</i>					
<b><sup>2</sup> Project Area (ft<sup>2</sup>):</b>	588,496* (13.51 acres)	<b><sup>3</sup> Number of Dwelling Units:</b>	n/a	<b><sup>4</sup> SIC Code:</b>	4225
<b><sup>5</sup> Is Project going to be phased?</b> <input type="checkbox"/> Yes <input checked="" type="checkbox"/> No <i>If yes, ensure that the WQMP evaluates each phase as a distinct DA, requiring LID BMPs to address runoff at time of completion.</i>					
<b><sup>6</sup> Does Project include roads?</b> <input type="checkbox"/> Yes <input checked="" type="checkbox"/> No <i>If yes, ensure that applicable requirements for road projects are addressed (see Appendix A of TGD for WQMP)</i>					

\* Approximately 0.34 acres of landscaped areas (including some driveway areas) along Schaefer Avenue will drain offsite without being routed to the BMPs. The landscaped areas are considered self-treating areas.

## 2.2 Property Ownership/Management

Describe the ownership/management of all portions of the project and site. State whether any infrastructure will transfer to public agencies (City, County, Caltrans, etc.) after project completion. State if a homeowners or property owners association will be formed and be responsible for the long-term maintenance of project stormwater facilities. Describe any lot-level stormwater features that will be the responsibility of individual property owners.

<b>Form 2.2-1 Property Ownership/Management</b>	
Describe property ownership/management responsible for long-term maintenance of WQMP stormwater facilities:	
CRP/Lovett Chino Industrial Owner, L.L.C. 610 Newport Center Drive, Suite 340 Newport Beach, CA 92660 Phone: (949) 402-2760 Contact: Tyler Banton	
No infrastructure will be transferred to a public agency after project completion. A property owner's association (POA) will not be formed for long-term maintenance of project stormwater facility.	

## 2.3 Potential Stormwater Pollutants

Determine and describe expected stormwater pollutants of concern based on land uses and site activities (refer to Table 3-3 in the TGD for WQMP).

<b>Form 2.3-1 Pollutants of Concern</b>			
Pollutant	Circle One: E=Expected, N=Not Expected	Listed for Receiving Water	Additional Information and Comments
Pathogens (Bacterial / Virus)	E	N	Bacterial indicators are routinely detected in pavement runoff.
Phosphorous	E	N	
Nitrogen	E	N	Expected pollutant since landscaping exists on-site.
Sediment / Total Suspended Solids	E	N	Expected pollutant from landscaping, roofs and pavement.
Metals	E	N	Expected pollutant from vehicle brake pad wear deposits.
Oil and Grease	E	N	Expected pollutant from vehicle fluid leakage.
Trash / Debris	E	N	
Pesticides / Herbicides	E	N	Expected pollutant since landscaping exists on-site.
Organic Compounds	E	N	Expected pollutant if landscaping exists on-site. Including petroleum hydrocarbons and solvents.
Oxygen Demanding Compounds	E	N	
Other:			

The expected POCs for the project site are **Indicator Bacteria, Nutrients (Nitrogen/Phosphorous, Metals (Copper and Lead).**

## 2.4 Water Quality Credits

A water quality credit program is applicable for certain types of development projects if it is not feasible to meet the requirements for on-site LID. Proponents for eligible projects, as described below, can apply for water quality credits that would reduce project obligations for selecting and sizing other treatment BMP or participating in other alternative compliance programs. Refer to Section 6.2 in the TGD for WQMP to determine if water quality credits are applicable for the project.

<b>Form 2.4-1 Water Quality Credits</b>			
<b><sup>1</sup> Project Types that Qualify for Water Quality Credits:</b> <i>Select all that apply</i>			
<input type="checkbox"/> Redevelopment projects that reduce the overall impervious footprint of the project site. [Credit = % impervious reduced]	Higher density development projects <input type="checkbox"/> Vertical density [20%] <input type="checkbox"/> 7 units/ acre [5%]	<input type="checkbox"/> Mixed use development, (combination of residential, commercial, industrial, office, institutional, or other land uses which incorporate design principles that demonstrate environmental benefits not realized through single use projects) [20%]	<input type="checkbox"/> Brownfield redevelopment (redevelop real property complicated by presence or potential of hazardous contaminants) [25%]
<input type="checkbox"/> Redevelopment projects in established historic district, historic preservation area, or similar significant core city center areas [10%]	<input type="checkbox"/> Transit-oriented developments (mixed use residential or commercial area designed to maximize access to public transportation) [20%]	<input type="checkbox"/> In-fill projects (conversion of empty lots & other underused spaces < 5 acres, substantially surrounded by urban land uses, into more beneficially used spaces, such as residential or commercial areas) [10%]	<input type="checkbox"/> Live-Work developments (variety of developments designed to support residential and vocational needs) [20%]
<b><sup>2</sup> Total Credit %:</b> n/a <i>(Total all credit percentages up to a maximum allowable credit of 50 percent)</i>			
<b>Description of Water Quality Credit Eligibility (if applicable)</b>	n/a		

The proposed project will **not** utilize any water quality credits.

## Section 3 Site and Watershed Description

Describe the project site conditions that will facilitate the selection of BMP through an analysis of the physical conditions and limitations of the site and its receiving waters. Identify distinct drainage areas (DA) that collect flow from a portion of the site and describe how runoff from each DA (and sub-watershed DMAs) is conveyed to the site outlet(s). Refer to Section 3.2 in the TGD for WQMP. Complete form 3.2 for each DA on the project site.

<b>Form 3-1 Site Location and Hydrologic Features</b>			
<b>Site coordinates</b> <i>Take GPS measurement at approximate center of site</i>	<b>Latitude:</b> 34.0058	<b>Longitude:</b> -117.7034	<b>Thomas Bros Map page:</b> Page 681
<sup>1</sup> <b>San Bernardino County climatic region:</b> <input checked="" type="checkbox"/> Valley <input type="checkbox"/> Mountain <input type="checkbox"/> Desert			
<sup>2</sup> <b>Does the site have more than one drainage area (DA):</b> <input type="checkbox"/> Yes <input checked="" type="checkbox"/> No <i>If no, proceed to Form 3-2. If yes, then use this form to show a conceptual schematic describing DMAs and hydrologic feature connecting DMAs to the site outlet(s). An example is provided below that can be modified for proposed project or a drawing clearly showing DMA and flow routing may be attached.</i>			

**Form 3-2 Existing Hydrologic Characteristics for Drainage Area (DA)**

For each drainage area's sub-watershed DMA, provide the following characteristics	Nodes 100-103	Nodes 110-111	Nodes 120-121	n/a
<sup>1</sup> DMA drainage area (ft <sup>2</sup> )	235,660 (5.41 acres)	177,289 (4.07 acres)	175,547 (4.03 acres)	n/a
<sup>2</sup> Existing site impervious area (ft <sup>2</sup> )	10,730	941	1,044	n/a
<sup>3</sup> Antecedent moisture condition <i>For desert areas, use <a href="http://www.sbcounty.gov/dpw/floodcontrol/pdf/20100412_map.pdf">http://www.sbcounty.gov/dpw/floodcontrol/pdf/20100412_map.pdf</a></i>	AMC II	AMC II	AMC II	n/a
<sup>4</sup> Hydrologic soil group <i>Refer to Watershed Mapping Tool – <a href="http://sbcounty.permitrack.com/WAP">http://sbcounty.permitrack.com/WAP</a></i>	HSG B	HSG B	HSG B	n/a
<sup>5</sup> Longest flowpath length (ft)	1,008	943	1,280	n/a
<sup>6</sup> Longest flowpath slope (ft/ft)	0.007	0.008	0.007	n/a
<sup>7</sup> Current land cover type(s) <i>Select from Fig C-3 of Hydrology Manual</i>	Barren Residential	Barren Residential	Barren Residential	n/a
<sup>8</sup> Pre-developed pervious area condition: <i>Based on the extent of wet season vegetated cover good &gt;75%; Fair 50-75%; Poor &lt;50% See Attachment A for photos of site to support rating</i>	Poor	Poor	Poor	n/a

<b>Form 3-3 Watershed Description</b>	
<p><b>Receiving Waters</b> Refer to Watershed Mapping Tool - <a href="http://sbcounty.permitrack.com/WAP">http://sbcounty.permitrack.com/WAP</a> See "Drainage Facilities" link at this website</p>	<p>Chino Creek, Reach 2 Chino Creek, Reach 1B Chino Creek, Reach 1A Santa Ana River, Reach 3 Santa Ana River, Reach 2 Santa Ana River, Reach 1 Pacific Ocean</p>
<p><b>Applicable TMDLs</b> Refer to Local Implementation Plan</p>	<p>Chino Creek, Reach 2: Indicator Bacteria Chino Creek, Reach 1B: Indicator Bacteria Chino Creek, Reach 1A: Indicator Bacteria Santa Ana River, Reach 3: Indicator Bacteria Santa Ana River, Reach 2: None Santa Ana River, Reach 1: None Pacific Ocean: None</p>
<p><b>303(d) listed impairments</b> Refer to Local Implementation Plan and Watershed Mapping Tool – <a href="http://sbcounty.permitrack.com/WAP">http://sbcounty.permitrack.com/WAP</a> and State Water Resources Control Board website – <a href="http://www.waterboards.ca.gov/santaana/water_iss/ues/programs/tmdl/index.shtml">http://www.waterboards.ca.gov/santaana/water_iss/ues/programs/tmdl/index.shtml</a></p>	<p>Chino Creek, Reach 2: Indicator Bacteria, pH Chino Creek, Reach 1B: Chemical Oxygen Demand (COD), Indicator Bacteria, Nutrients Chino Creek, Reach 1A: Indicator Bacteria, Nutrients Santa Ana River, Reach 3: Copper, Indicator Bacteria, Lead Santa Ana River, Reach 2: None Santa Ana River, Reach 1: None Pacific Ocean: None</p>
<p><b>Environmentally Sensitive Areas (ESA)</b> Refer to Watershed Mapping Tool – <a href="http://sbcounty.permitrack.com/WAP">http://sbcounty.permitrack.com/WAP</a></p>	<p>n/a</p>
<p><b>Unlined Downstream Water Bodies</b> Refer to Watershed Mapping Tool – <a href="http://sbcounty.permitrack.com/WAP">http://sbcounty.permitrack.com/WAP</a></p>	<p>Chino Creek Santa Ana River</p>
<p><b>Hydrologic Conditions of Concern</b></p>	<p><input checked="" type="checkbox"/> Yes Complete Hydrologic Conditions of Concern (HCOC) Assessment. Include Forms 4.2-2 through Form 4.2-5 and Hydromodification BMP Form 4.3-10 in submittal <input type="checkbox"/> No</p>
<p><b>Watershed-based BMP included in a RWQCB approved WAP</b></p>	<p><input type="checkbox"/> Yes Attach verification of regional BMP evaluation criteria in WAP</p> <ul style="list-style-type: none"> <li>• More Effective than On-site LID</li> <li>• Remaining Capacity for Project DCV</li> <li>• Upstream of any Water of the US</li> <li>• Operational at Project Completion</li> <li>• Long-Term Maintenance Plan</li> </ul> <p><input checked="" type="checkbox"/> No</p>

## Section 4 Best Management Practices (BMP)

### 4.1 Source Control BMP

#### 4.1.1 Pollution Prevention

Non-structural and structural source control BMP are required to be incorporated into all new development and significant redevelopment projects. Form 4.1-1 and 4.1-2 are used to describe specific source control BMPs used in the WQMP or to explain why a certain BMP is not applicable. Table 7-3 of the TGD for WQMP provides a list of applicable source control BMP for projects with specific types of potential pollutant sources or activities. The source control BMP in this table must be implemented for projects with these specific types of potential pollutant sources or activities.

The preparers of this WQMP have reviewed the source control BMP requirements for new development and significant redevelopment projects. The preparers have also reviewed the specific BMP required for project as specified in Forms 4.1-1 and 4.1-2. All applicable non-structural and structural source control BMP shall be implemented in the project.

**Water Quality Management Plan (WQMP)  
Yorba Avenue Industrial Development**

<b>Form 4.1-1 Non-Structural Source Control BMPs</b>				
Identifier	Name	Check One		Describe BMP Implementation OR, if not applicable, state reason
		Included	Not Applicable	
N1	Education of Property Owners, Tenants and Occupants on Stormwater BMPs	X		Property owner will familiarize him/herself with the educational materials in Section 6.4, Attachment "E" and the contents of the WQMP.
N2	Activity Restrictions	X		No outdoor work areas, processing, storage or wash area. Activities are restricted to only those for which a BMP has been implemented and will be enforced through lease agreements and CC&R's.
N3	Landscape Management BMPs	X		Irrigation must be consistent with City's Water Conservation Ordinance. Fertilizer and pesticide usage will be consistent with County Management Guidelines for Use of Fertilizers and Pesticides. Mowing and trimming waste shall be properly removed from the site and herbicides, pesticides and fertilizers shall be properly applied to prevent storm drainage contamination.
N4	BMP Maintenance	X		BMP maintenance, implementation schedules, and responsible parties are included with each specific BMP narrative in Form 5-1.
N5	Title 22 CCR Compliance (How development will comply)		X	If hazardous materials are stored onsite they shall be handled, labeled and disposed of in accordance with all Title 22 CCR regulations.
N6	Local Water Quality Ordinances	X		Owner/tenants will operate in compliance with the City of Chino Water Quality Ordinance.
N7	Spill Contingency Plan	X		Owner/tenant will prepare spill contingency plans based on hazmat regulations and individual site needs.
N8	Underground Storage Tank Compliance		X	No USTs onsite.
N9	Hazardous Materials Disclosure Compliance		X	If hazardous materials are stored/used onsite, the owners shall provide all required public disclosure.
N10	Uniform Fire Code Implementation	X		Owner will comply with Article 80 of the Uniform Fire Code enforced by the fire protection agency.
N11	Litter/Debris Control Program	X		Owner shall contract with their landscape maintenance firm to provide this service during regularly schedule maintenance.
N12	Employee Training	X		The owner will ensure that tenants are also familiar with onsite BMPs and necessary maintenance required of the tenants. Owner will check with City and County at least once a year to obtain new or updated educational materials and provide these materials to tenants. Employees shall be trained to clean up spills and participate in ongoing maintenance. The WQMP requires annual employee training and new hires within 2 months.
N13	Housekeeping of Loading Docks	X		Keep all fluids indoors. Clean up spills immediately and keep spills from entering storm drain system. No direct discharges into the storm drain system. Area shall be inspected weekly for proper containment and practices with spills cleaned up immediately and disposed of properly.

**Water Quality Management Plan (WQMP)  
Yorba Avenue Industrial Development**

<b>Form 4.1-1 Non-Structural Source Control BMPs</b>				
Identifier	Name	Check One		Describe BMP Implementation OR, if not applicable, state reason
		Included	Not Applicable	
N14	Catch Basin Inspection Program	X		Monthly inspection by property owner's designee for debris accumulation and evidence of illegal discharges. Catch basins and filter inserts will be vacuumed when sediment or trash becomes 2-inches deep and disposed of properly.
N15	Vacuum Sweeping of Private Streets and Parking Lots	X		All landscape maintenance contractors will be required to sweep up all landscape cuttings, mowings and fertilizer materials off paved areas weekly and dispose of properly. Parking areas and drive ways will be vacuum swept monthly by sweeping contractor.
N16	Other Non-structural Measures for Public Agency Projects		X	Not a public agency project.
N17	Comply with all other applicable NDPES permits	X		Owners will comply with the Construction General Permit and the tenant shall comply with the Industrial General Permit requirements, as needed.

**Water Quality Management Plan (WQMP)  
Yorba Avenue Industrial Development**

**Form 4.1-2 Structural Source Control BMPs**

Identifier	Name	Check One		Describe BMP Implementation OR, if not applicable, state reason
		Included	Not Applicable	
S1	Provide storm drain system stenciling and signage (CASQA New Development BMP Handbook SD-13)	X		“No Dumping – Drains to River” painted stencils will be applied to concrete pavement adjacent to each storm drain inlet. Legibility of stencil will be maintained on a yearly basis.
S2	Design and construct outdoor material storage areas to reduce pollution introduction (CASQA New Development BMP Handbook SD-34)		X	No outdoor material storage areas onsite and owners shall prohibit outdoor material storage by employees and tenants.
S3	Design and construct trash and waste storage areas to reduce pollution introduction (CASQA New Development BMP Handbook SD-32)	X		Trash enclosures shall be roofed with a solid canopy style roof and paved with an impervious surface, designed not to allow run-on from adjoining areas, designed to divert drainage from adjoining roofs and pavements around the area, and screened or walled to prevent off-site transport of trash.
S4	Use efficient irrigation systems & landscape design, water conservation, smart controllers, and source control (Statewide Model Landscape Ordinance; CASQA New Development BMP Handbook SD-12)	X		Irrigation systems shall include reducers or shutoff valves triggered by a pressure drop to control water loss in the event of broken sprinkler heads or lines. Timers will be used to avoid over watering and watering cycles and duration shall be adjusted seasonally by the landscape maintenance contractor. The landscaping areas will be grouped with plants that have similar water requirements. Native or drought tolerant species shall also be used where appropriate to reduce excess irrigation runoff and promote surface filtration.
S5	Finish grade of landscaped areas at a minimum of 1-2 inches below top of curb, sidewalk, or pavement	X		Finish grades of landscaped areas will be depressed 1”-2” below top of curbs in order to increase retention of stormwater/irrigation water and promote infiltration.
S6	Protect slopes and channels and provide energy dissipation (CASQA New Development BMP Handbook SD-10)		X	No slopes proposed.
S7	Covered dock areas (CASQA New Development BMP Handbook SD-31)		X	Finished goods being loaded and unloaded will be through ‘dock high’ rollup doors/docks to reduce the potential to contribute to stormwater pollution. No direct connections will be made to a MS4. Paved parking lot under rollup doors shall be swept weekly.
S8	Covered maintenance bays with spill containment plans (CASQA New Development BMP Handbook SD-31)		X	No maintenance bays onsite and owners will prohibit vehicle maintenance onsite through activity restrictions.
S9	Vehicle wash areas with spill containment plans (CASQA New Development BMP Handbook SD-33)		X	No vehicle wash areas onsite and owners will prohibit truck/vehicle washing onsite through activity restrictions.
S10	Covered outdoor processing areas (CASQA New Development BMP Handbook SD-36)		X	No outdoor processing areas onsite and owners will prohibit the activity.

**Water Quality Management Plan (WQMP)  
Yorba Avenue Industrial Development**

**Form 4.1-2 Structural Source Control BMPs**

Identifier	Name	Check One		Describe BMP Implementation OR, if not applicable, state reason
		Included	Not Applicable	
S11	Equipment wash areas with spill containment plans (CASQA New Development BMP Handbook SD-33)		X	No equipment wash areas onsite and owners will prohibit this activity.
S12	Fueling areas (CASQA New Development BMP Handbook SD-30)		X	No fueling areas onsite.
S13	Hillside landscaping (CASQA New Development BMP Handbook SD-10)		X	No hillsides onsite.
S14	Wash water control for food preparation areas		X	No food preparation onsite.
S15	Community car wash racks (CASQA New Development BMP Handbook SD-33)		X	No community cars wash racks onsite.

### 4.1.2 Preventive LID Site Design Practices

Site design practices associated with new LID requirements in the MS4 Permit should be considered in the earliest phases of a project. Preventative site design practices can result in smaller DCV for LID BMP and hydromodification control BMP by reducing runoff generation. Describe site design and drainage plan including:

- A narrative of site design practices utilized or rationale for not using practices
- A narrative of how site plan incorporates preventative site design practices
- Include an attached Site Plan layout which shows how preventative site design practices are included in WQMP

Refer to Section 5.2 of the TGD for WQMP for more details.

<b>Form 4.1-3 Preventive LID Site Design Practices Checklist</b>	
<b>Site Design Practices</b> <i>If yes, explain how preventative site design practice is addressed in project site plan. If no, other LID BMPs must be selected to meet targets.</i>	
<b>Minimize impervious areas:</b> <input type="checkbox"/> Yes <input checked="" type="checkbox"/> No	Not applicable, development consists of a light industrial facility. Most areas will be paved; however, disturbed areas will be fully stabilized with landscaping and overflow runoff collected by the underground infiltration chambers.
<b>Maximize natural infiltration capacity:</b> <input checked="" type="checkbox"/> Yes <input type="checkbox"/> No	The proposed underground chambers will maximize natural infiltration into the subsoil below the chambers.
<b>Preserve existing drainage patterns and time of concentration:</b> <input checked="" type="checkbox"/> Yes <input type="checkbox"/> No	Post-development drainage patterns will mimic pre-development conditions.
<b>Disconnect impervious areas:</b> <input checked="" type="checkbox"/> Yes <input type="checkbox"/> No	The underground infiltration chambers and biofiltration system will disconnect impervious areas before discharging offsite.
<b>Protect existing vegetation and sensitive areas:</b> <input type="checkbox"/> Yes <input checked="" type="checkbox"/> No	Not applicable. No sensitive areas with native vegetation to protect. The site is being developed into a light industrial facility.
<b>Re-vegetate disturbed areas:</b> <input type="checkbox"/> Yes <input checked="" type="checkbox"/> No	Not applicable, development consists of a light industrial facility. Most of the disturbed areas will be paved; however, remaining disturbed areas not built-over, will be landscaped with drought tolerant plants and overflow runoff collected by the underground infiltration chambers.
<b>Minimize unnecessary compaction in stormwater retention/infiltration basin/trench areas:</b> <input checked="" type="checkbox"/> Yes <input type="checkbox"/> No	Heavy construction vehicles will be prohibited from unnecessary soil compaction around landscape and BMP areas and retention/infiltration pits shall not be over-excavated, to prevent backfilling and re-compaction of base soil, in pits. A note will be placed on grading plan sheets, requiring this.
<b>Utilize vegetated drainage swales in place of underground piping or imperviously lined swales:</b> <input type="checkbox"/> Yes <input checked="" type="checkbox"/> No	Underground piping and imperviously lined swales are located at truck and car loading areas that could not be substituted with vegetated swales. All imperviously lined swales will be directed to the underground infiltration chambers.
<b>Stake off areas that will be used for landscaping to minimize compaction during construction :</b> <input checked="" type="checkbox"/> Yes <input type="checkbox"/> No	Landscaped/BMP areas will be staked to minimize unnecessary compaction during construction.

## 4.2 Project Performance Criteria

The purpose of this section of the Project WQMP is to establish targets for post development hydrology based on performance criteria specified in the MS4 Permit. These targets include runoff volume for water quality control (referred to as LID design capture volume), and runoff volume, time of concentration, and peak runoff for protection of any downstream waterbody segments with a HCOC. ***If the project has more than one outlet for stormwater runoff, then complete additional versions of these forms for each DA / outlet.***

Methods applied in the following forms include:

- For LID BMP Design Capture Volume (DCV), the San Bernardino County Stormwater Program requires use of the P6 method (MS4 Permit Section XI.D.6a.ii) – Form 4.2-1
- For HCOC pre- and post-development hydrologic calculation, the San Bernardino County Stormwater Program requires the use of the Rational Method (San Bernardino County Hydrology Manual Section D). Forms 4.2-2 through Form 4.2-5 calculate hydrologic variables including runoff volume, time of concentration, and peak runoff from the project site pre- and post-development using the Hydrology Manual Rational Method approach. For projects greater than 640 acres (1.0 mi<sup>2</sup>), the Rational Method and these forms should not be used. For such projects, the Unit Hydrograph Method (San Bernardino County Hydrology Manual Section E) shall be applied for hydrologic calculations for HCOC performance criteria.

Refer to Section 4 in the TGD for WQMP for detailed guidance and instructions.

<b>Form 4.2-1 LID BMP Performance Criteria for Design Capture Volume (DMA 1)</b>	
<sup>1</sup> Project area (ft <sup>2</sup> ): 573,685 (DMA 1 – 13.17 ac)	<sup>2</sup> Imperviousness after applying preventative site design practices (Imp%): 95%
<sup>3</sup> Runoff Coefficient (R <sub>c</sub> ): 0.807 $R_c = 0.858(\text{Imp}\%)^3 - 0.78(\text{Imp}\%)^2 + 0.774(\text{Imp}\%) + 0.04$	
<sup>4</sup> Determine 1-hour rainfall depth for a 2-year return period P <sub>2yr-1hr</sub> (in): 0.594 <a href="http://hdsc.nws.noaa.gov/hdsc/pfds/sa/sca_pfds.html">http://hdsc.nws.noaa.gov/hdsc/pfds/sa/sca_pfds.html</a>	
<sup>5</sup> Compute P6, Mean 6-hr Precipitation (inches): 0.880 <i>P6 = Item 4 * C<sub>1</sub>, where C<sub>1</sub> is a function of site climatic region specified in Form 3-1 Item 1 (Valley = 1.4807; Mountain = 1.909; Desert = 1.2371)</i>	
<sup>6</sup> Drawdown Rate <i>Use 48 hours as the default condition. Selection and use of the 24 hour drawdown time condition is subject to approval by the local jurisdiction. The necessary BMP footprint is a function of drawdown time. While shorter drawdown times reduce the performance criteria for LID BMP design capture volume, the depth of water that can be stored is also reduced.</i>	24-hrs <input type="checkbox"/> 48-hrs <input checked="" type="checkbox"/>
<sup>7</sup> Compute design capture volume, DCV (ft <sup>3</sup> ): 66,645 <i>DCV = 1/12 * [Item 1 * Item 3 * Item 5 * C<sub>2</sub>], where C<sub>2</sub> is a function of drawdown rate (24-hr = 1.582; 48-hr = 1.963) Compute separate DCV for each outlet from the project site per schematic drawn in Form 3-1 Item 2</i>	

### Form 4.2-2 Summary of HCOC Assessment

Does project have the potential to cause or contribute to an HCOC in a downstream channel:  Yes  No

Go to: <http://sbcounty.permitrack.com/WAP/>

If "Yes", then complete HCOC assessment of site hydrology for 2yr storm event using Forms 4.2-3 through 4.2-5 and insert results below (Forms 4.2-3 through 4.2-5 may be replaced by computer software analysis based on the San Bernardino County Hydrology Manual)

If "No," then proceed to Section 4.3 Project Conformance Analysis

Condition	Runoff Volume (ft <sup>3</sup> )	Time of Concentration (min)	Peak Runoff (cfs)
<b>Pre-developed</b>	<sup>1</sup> 39,525 <i>Form 4.2-3 Item 12</i>	<sup>2</sup> N/A <i>Form 4.2-4 Item 13</i>	<sup>3</sup> N/A <i>Form 4.2-5 Item 10</i>
<b>Post-developed</b>	<sup>4</sup> 109,736 <i>Form 4.2-3 Item 13</i>	<sup>5</sup> N/A <i>Form 4.2-4 Item 14</i>	<sup>6</sup> N/A <i>Form 4.2-5 Item 14</i>
<b>Difference</b>	<sup>7</sup> 70,211 <i>Item 4 – Item 1</i>	<sup>8</sup> N/A <i>Item 5 – Item 2</i>	<sup>9</sup> N/A <i>Item 6 – Item 3</i>
<b>Difference</b> (as % of pre-developed)	<sup>10</sup> 178% <i>Item 7 / Item 1</i>	<sup>11</sup> N/A <i>Item 8 / Item 2</i>	<sup>12</sup> N/A <i>Item 9 / Item 3</i>

To meet HCOC requirements, a mitigation volume must be achieved by using LID and/or hydromodification mitigation BMPs. The mitigation volume is approximately 64,724 cu-ft ((0.95 \* 109,736) – 39,525). The total volume being detained/retained is 66,799 cu-ft which is greater than the mitigation volume needed. As a result, the mitigation volume has been contained by the proposed BMPs. Since the mitigation volume has been met, it is physically impossible for the project to avoid increasing the time of concentration and reducing peak runoff by more than five percent of pre-development conditions (see Section 5.6.1 of the Technical Guidance Document for more information).

### Form 4.2-3 HCOC Assessment for Runoff Volume

Compute weighted curve number for pre and post developed conditions	Pre-developed DA <i>Add more columns if more than 4 DMA</i>				Post-developed DA <i>Add more columns if more than 4 DMA</i>			
	DMA A	DMA B	DMA C	DMA D	DMA A	DMA B	DMA C	DMA D
<sup>1</sup> Land Cover type	Open Brush (fair cover)	Barren	Impervious Cover		Roof, Asphalt & Concrete	Urban Cover Comm. Landscape		
<sup>2</sup> Hydrologic Soil Group (HSG)	B	B	B		B	B		
<sup>3</sup> DMA Area, ft <sup>2</sup> <i>sum of areas of DMA should equal area of DA</i>	307,098	268,584	12,814		559,071	29,425		
<sup>4</sup> Curve Number (CN) <i>Use Items 1 and 2 to select the appropriate CN from Appendix C-2 of the TGD for WQMP</i>	66	86	98		98	56		
	<sup>5</sup> Pre-Developed area-weighted CN: 76				<sup>6</sup> Post-Developed area-weighted CN: 96			
	<sup>7</sup> Pre-developed soil storage capacity, S (in): 3.16 <i>S = (1000 / Item 5) - 10</i>				<sup>8</sup> Post-developed soil storage capacity, S (in): 0.42 <i>S = (1000 / Item 6) - 10</i>			
	<sup>9</sup> Initial abstraction, I <sub>a</sub> (in): 0.63 <i>I<sub>a</sub> = 0.2 * Item 7</i>				<sup>10</sup> Initial abstraction, I <sub>a</sub> (in): 0.08 <i>I<sub>a</sub> = 0.2 * Item 8</i>			
<sup>11</sup> Precipitation for 2 yr, 24 hr storm (in): 2.68 <i>Go to: <a href="http://hdsc.nws.noaa.gov/hdsc/pfds/sa/sca_pfds.html">http://hdsc.nws.noaa.gov/hdsc/pfds/sa/sca_pfds.html</a></i>								
<sup>12</sup> Pre-developed Volume (ft <sup>3</sup> ): 39,525 <i>V<sub>pre</sub> = (1 / 12) * (Item sum of Item 3) * [(Item 11 - Item 9)^2 / ((Item 11 - Item 9 + Item 7))]</i>								
<sup>13</sup> Post-developed Volume (ft <sup>3</sup> ): 109,736 <i>V<sub>pre</sub> = (1 / 12) * (Item sum of Item 3) * [(Item 11 - Item 10)^2 / ((Item 11 - Item 10 + Item 8))]</i>								
<sup>14</sup> Volume Reduction needed to meet HCOC Requirement, (ft <sup>3</sup> ): 64,724 <i>V<sub>HCOC</sub> = (Item 13 * 0.95) - Item 12</i>								

**Water Quality Management Plan (WQMP)  
Yorba Avenue Industrial Development**

**Form 4.2-4 HCOC Assessment for Time of Concentration**

Compute time of concentration for pre and post developed conditions for each DA (For projects using the Hydrology Manual complete the form below)

Variables	Pre-developed DA <i>Add more columns if more than 4 DMA</i>				Post-developed DA <i>Add more columns if more than 4 DMA</i>			
	DMA A	DMA B	DMA C	DMA D	DMA A	DMA B	DMA C	DMA D
<sup>1</sup> Length of flowpath (ft) <i>Use Form 3-2 Item 5 for pre-developed condition</i>								
<sup>2</sup> Change in elevation (ft)								
<sup>3</sup> Slope (ft/ft), $S_o = \text{Item 2} / \text{Item 1}$								
<sup>4</sup> Land cover								
<sup>5</sup> Initial DMA Time of Concentration (min) <i>Appendix C-1 of the TGD for WQMP</i>								
<sup>6</sup> Length of conveyance from DMA outlet to project site outlet (ft) <i>May be zero if DMA outlet is at project site outlet</i>								
<sup>7</sup> Cross-sectional area of channel (ft <sup>2</sup> )								
<sup>8</sup> Wetted perimeter of channel (ft)								
<sup>9</sup> Manning's roughness of channel (n)								
<sup>10</sup> Channel flow velocity (ft/sec) $V_{fps} = (1.49 / \text{Item 9}) * (\text{Item 7} / \text{Item 8})^{0.67} * (\text{Item 3})^{0.5}$								
<sup>11</sup> Travel time to outlet (min) $T_t = \text{Item 6} / (\text{Item 10} * 60)$								
<sup>12</sup> Total time of concentration (min) $T_c = \text{Item 5} + \text{Item 11}$								
<sup>13</sup> Pre-developed time of concentration (min): <i>Minimum of Item 12 pre-developed DMA</i>								
<sup>14</sup> Post-developed time of concentration (min): <i>Minimum of Item 12 post-developed DMA</i>								
<sup>15</sup> Additional time of concentration needed to meet HCOC requirement (min): $T_{CHCOC} = (\text{Item 14} * 0.95) - \text{Item 13}$								

**Water Quality Management Plan (WQMP)  
Yorba Avenue Industrial Development**

**Form 4.2-5 HCOC Assessment for Peak Runoff**

Compute peak runoff for pre and post developed conditions

Variables	Pre-developed DA <i>Add more columns if more than 3 DMA</i>			Post-developed DA <i>Add more columns if more than 3 DMA</i>		
	DMA A	DMA B	DMA C	DMA A	DMA B	DMA C
<sup>1</sup> Rainfall Intensity for storm duration equal to time of concentration $I_{peak} = 10^{(LOG Form 4.2-1 Item 4 - 0.6 LOG Form 4.2-4 Item 5 / 60)}$						
<sup>2</sup> Drainage Area of each DMA (ft <sup>2</sup> ) <i>For DMA with outlet at project site outlet, include upstream DMA (Using example schematic in Form 3-1, DMA A will include drainage from DMA C)</i>						
<sup>3</sup> Ratio of pervious area to total area <i>For DMA with outlet at project site outlet, include upstream DMA (Using example schematic in Form 3-1, DMA A will include drainage from DMA C)</i>						
<sup>4</sup> Pervious area infiltration rate (in/hr) <i>Use pervious area CN and antecedent moisture condition with Appendix C-3 of the TGD for WQMP</i>						
<sup>5</sup> Maximum loss rate (in/hr) $F_m = Item 3 * Item 4$ <i>Use area-weighted Fm from DMA with outlet at project site outlet, include upstream DMA (Using example schematic in Form 3-1, DMA A will include drainage from DMA C)</i>						
<sup>6</sup> Peak Flow from DMA (cfs) $Q_p = Item 2 * 0.9 * (Item 1 - Item 5)$						
<sup>7</sup> Time of concentration adjustment factor for other DMA to site discharge point <i>Form 4.2-4 Item 12 DMA / Other DMA upstream of site discharge point (If ratio is greater than 1.0, then use maximum value of 1.0)</i>	DMA A	n/a		n/a		
	DMA B		n/a		n/a	
	DMA C		n/a			n/a
<sup>8</sup> Pre-developed $Q_p$ at $T_c$ for DMA A: $Q_p = Item 6_{DMAA} + [Item 6_{DMAB} * (Item 1_{DMAA} - Item 5_{DMAB}) / (Item 1_{DMAB} - Item 5_{DMAB}) * Item 7_{DMAA/2}] + [Item 6_{DMAC} * (Item 1_{DMAA} - Item 5_{DMAC}) / (Item 1_{DMAC} - Item 5_{DMAC}) * Item 7_{DMAA/3}]$	<sup>9</sup> Pre-developed $Q_p$ at $T_c$ for DMA B: $Q_p = Item 6_{DMAB} + [Item 6_{DMAA} * (Item 1_{DMAB} - Item 5_{DMAA}) / (Item 1_{DMAA} - Item 5_{DMAA}) * Item 7_{DMAB/1}] + [Item 6_{DMAC} * (Item 1_{DMAB} - Item 5_{DMAC}) / (Item 1_{DMAC} - Item 5_{DMAC}) * Item 7_{DMAB/3}]$			<sup>10</sup> Pre-developed $Q_p$ at $T_c$ for DMA C: $Q_p = Item 6_{DMAC} + [Item 6_{DMAA} * (Item 1_{DMAC} - Item 5_{DMAA}) / (Item 1_{DMAA} - Item 5_{DMAA}) * Item 7_{DMAC/1}] + [Item 6_{DMAB} * (Item 1_{DMAC} - Item 5_{DMAB}) / (Item 1_{DMAB} - Item 5_{DMAB}) * Item 7_{DMAC/2}]$		
<sup>11</sup> Peak runoff from pre-developed condition confluence analysis (cfs): <i>Maximum of Item 8, 9, and 10</i>						
<sup>12</sup> Post-developed $Q_p$ at $T_c$ for DMA A: <i>Same as Item 8 for post-developed values</i>	<sup>13</sup> Post-developed $Q_p$ at $T_c$ for DMA B: <i>Same as Item 9 for post-developed values</i>			<sup>14</sup> Post-developed $Q_p$ at $T_c$ for DMA C: <i>Same as Item 10 for post-developed values</i>		
<sup>15</sup> Peak runoff from post-developed condition confluence analysis (cfs): <i>Maximum of Item 12, 13, and 14</i>						
<sup>16</sup> Peak runoff reduction needed to meet HCOC Requirement (cfs): $Q_{p-HCOC} = (Item 14 * 0.95) - Item 11$						

## 4.3 Project Conformance Analysis

Complete the following forms for each project site DA to document that the proposed LID BMPs conform to the project DCV developed to meet performance criteria specified in the MS4 Permit (WQMP Template Section 4.2). For the LID DCV, the forms are ordered according to hierarchy of BMP selection as required by the MS4 Permit (see Section 5.3.1 in the TGD for WQMP). The forms compute the following for on-site LID BMP:

- Site Design and Hydrologic Source Controls (Form 4.3-2)
- Retention and Infiltration (Form 4.3-3)
- Harvested and Use (Form 4.3-4) or
- Biotreatment (Form 4.3-5).

At the end of each form, additional fields facilitate the determination of the extent of mitigation provided by the specific BMP category, allowing for use of the next category of BMP in the hierarchy, if necessary.

The first step in the analysis, using Section 5.3.2.1 of the TGD for WQMP, is to complete Forms 4.3-1 and 4.3-3) to determine if retention and infiltration BMPs are infeasible for the project. For each feasibility criterion in Form 4.3-1, if the answer is “Yes,” provide all study findings that includes relevant calculations, maps, data sources, etc. used to make the determination of infeasibility.

Next, complete Forms 4.3-2 and 4.3-4 to determine the feasibility of applicable HSC and harvest and use BMPs, and, if their implementation is feasible, the extent of mitigation of the DCV.

If no site constraints exist that would limit the type of BMP to be implemented in a DA, evaluate the use of combinations of LID BMPs, including all applicable HSC BMPs to maximize on-site retention of the DCV. If no combination of BMP can mitigate the entire DCV, implement the single BMP type, or combination of BMP types, that maximizes on-site retention of the DCV within the minimum effective area.

If the combination of LID HSC, retention and infiltration, and harvest and use BMPs are unable to mitigate the entire DCV, then biotreatment BMPs may be implemented by the project proponent. If biotreatment BMPs are used, then they must be sized to provide sufficient capacity for effective treatment of the remainder of the volume-based performance criteria that cannot be achieved with LID BMPs (TGD for WQMP Section 5.4.4.2). Under no circumstances shall any portion of the DCV be released from the site without effective mitigation and/or treatment.

## Form 4.3-1 Infiltration BMP Feasibility (DMA 1)

Feasibility Criterion – Complete evaluation for each DMA on the Project Site

**<sup>1</sup> Would infiltration BMP pose significant risk for groundwater related concerns?** Yes No

*Refer to Section 5.3.2.1 of the TGD for WQMP*

If Yes, Provide basis: (attach)

**<sup>2</sup> Would installation of infiltration BMP significantly increase the risk of geotechnical hazards?** Yes No

*(Yes, if the answer to any of the following questions is yes, as established by a geotechnical expert):*

- *The location is less than 50 feet away from slopes steeper than 15 percent*
- *The location is less than eight feet from building foundations or an alternative setback.*
- *A study certified by a geotechnical professional or an available watershed study determines that stormwater infiltration would result in significantly increased risks of geotechnical hazards.*

If Yes, Provide basis: (attach)

**<sup>3</sup> Would infiltration of runoff on a Project site violate downstream water rights?** Yes No

If Yes, Provide basis: (attach)

**<sup>4</sup> Is proposed infiltration facility located on hydrologic soil group (HSG) D soils or does the site geotechnical investigation indicate presence of soil characteristics, which support categorization as D soils?** Yes No

If Yes, Provide basis: (attach)

**<sup>5</sup> Is the design infiltration rate, after accounting for safety factor of 2.0, below proposed facility less than 0.3 in/hr (accounting for soil amendments)?** Yes No

If Yes, Provide basis:

**<sup>6</sup> Would on-site infiltration or reduction of runoff over pre-developed conditions be partially or fully inconsistent with watershed management strategies as defined in the WAP, or impair beneficial uses?** Yes No

*See Section 3.5 of the TGD for WQMP and WAP*

If Yes, Provide basis: (attach)

**<sup>7</sup> Any answer from Item 1 through Item 3 is “Yes”:** Yes No

*If yes, infiltration of any volume is not feasible onsite. Proceed to Form 4.3-4, Harvest and Use BMP. If no, then proceed to Item 9 below.*

**<sup>8</sup> Any answer from Item 4 through Item 6 is “Yes”:** Yes No

*If yes, infiltration is permissible but is not required to be considered. Proceed to Form 4.3-2, Hydrologic Source Control BMP.*

*If no, then proceed to Item 9, below.*

**<sup>9</sup> All answers to Item 1 through Item 6 are “No”:** Yes No

*Infiltration of the full DCV is potentially feasible, LID infiltration BMP must be designed to infiltrate the full DCV to the MEP.*

*Proceed to Form 4.3-2, Hydrologic Source Control BMP.*

### **4.3.1 Site Design Hydrologic Source Control BMP**

Section XI.E. of the Permit emphasizes the use of LID preventative measures; and the use of LID HSC BMPs reduces the portion of the DCV that must be addressed in downstream BMPs. Therefore, all applicable HSC shall be provided except where they are mutually exclusive with each other, or with other BMPs. Mutual exclusivity may result from overlapping BMP footprints such that either would be potentially feasible by itself, but both could not be implemented. Please note that while there are no numeric standards regarding the use of HSC, if a project cannot feasibly meet BMP sizing requirements or cannot fully address HCOCs, feasibility of all applicable HSC must be part of demonstrating that the BMP system has been designed to retain the maximum feasible portion of the DCV. Complete Form 4.3-2 to identify and calculate estimated retention volume from implementing site design HSC BMP. Refer to Section 5.4.1 in the TGD for more detailed guidance.

<b>Form 4.3-2 Site Design Hydrologic Source Control BMPs</b>			
<b>1 Implementation of Impervious Area Dispersion BMP (i.e. routing runoff from impervious to pervious areas), excluding impervious areas planned for routing to on-lot infiltration BMP):</b> <input type="checkbox"/> Yes <input checked="" type="checkbox"/> No <i>If yes, complete Items 2-5; If no, proceed to Item 6</i>			
<b>Variables</b>	<b>BMP Type and DA</b>	<b>BMP Type and DA</b>	<b>BMP Type and DA</b>
<i>Aggregate impervious area dispersion with equal ratios of pervious to impervious;</i>			
<b>2 Total impervious area draining to pervious area</b>			
<b>3 Ratio of pervious area receiving runoff to impervious area</b>			
<b>4 Retention volume achieved from impervious area dispersion (ft<sup>3</sup>)</b> <i>V = Item 2 * Item 3 * (0.5/12), assuming retention of 0.5 inches of runoff</i>			
<b>5 Sum of retention volume achieved from impervious area dispersion (ft<sup>3</sup>):</b> <i>V<sub>retention</sub> = Sum of Item 4 for all BMPs</i>			
<b>6 Implementation of Localized On-lot Infiltration BMPs (e.g. on-lot rain gardens):</b> <input type="checkbox"/> Yes <input checked="" type="checkbox"/> No <i>If yes, complete Items 7-13 for aggregate of all on-lot infiltration BMP in each DA; If no, proceed to Item 14</i>			
<b>BMP Type and DA</b>	<b>BMP Type and DA</b>	<b>BMP Type and DA</b>	<b>BMP Type and DA</b>
<b>7 Ponding surface area (ft<sup>2</sup>)</b>			
<b>8 Ponding depth (ft)</b>			
<b>9 Surface area of amended soil/gravel (ft<sup>2</sup>)</b>			
<b>10 Average depth of amended soil/gravel (ft)</b>			
<b>11 Average porosity of amended soil/gravel</b>			
<b>12 Retention volume achieved from on-lot infiltration (ft<sup>3</sup>)</b> <i>V<sub>retention</sub> = (Item 7 * Item 8) + (Item 9 * Item 10 * Item 11)</i>			
<b>13 Runoff volume retention from on-lot infiltration (ft<sup>3</sup>):</b> <i>V<sub>retention</sub> = Sum of Item 12 for all BMPs</i>			
<b>14 Implementation of evapotranspiration BMP (green, brown, or blue roofs):</b> <input type="checkbox"/> Yes <input checked="" type="checkbox"/> No <i>If yes, complete Items 15-20. If no, proceed to Item 21</i>			
<b>BMP Type and DA</b>	<b>BMP Type and DA</b>	<b>BMP Type and DA</b>	<b>BMP Type and DA</b>
<b>15 Rooftop area planned for ET BMP (ft<sup>2</sup>)</b>			
<b>16 Average wet season ET demand (in/day)</b> <i>Use local values, typical ~ 0.1</i>			
<b>17 Daily ET demand (ft<sup>3</sup>/day)</b> <i>Item 15 * (Item 16 / 12)</i>			
<b>18 Drawdown time (hrs)</b> <i>Copy Item 6 in Form 4.2-1</i>			
<b>19 Retention Volume (ft<sup>3</sup>)</b> <i>V<sub>retention</sub> = Item 17 * (Item 18 / 24)</i>			
<b>20 Runoff volume retention from evapotranspiration BMPs (ft<sup>3</sup>):</b> <i>V = Sum of Item 19 for all BMPs</i>			
<b>21 Implementation of Street Trees:</b> <input type="checkbox"/> Yes <input checked="" type="checkbox"/> No <i>If yes, complete Items 20-2. If no, proceed to Item 26</i>			
<b>BMP Type and DA</b>	<b>BMP Type and DA</b>	<b>BMP Type and DA</b>	<b>BMP Type and DA</b>
<b>22 Number of Street Trees</b>			
<b>23 Average canopy cover over impervious area (ft<sup>2</sup>)</b>			
<b>24 Runoff volume retention from street trees (ft<sup>3</sup>)</b> <i>V<sub>retention</sub> = Item 22 * Item 23 * (0.05/12) assume runoff retention of 0.05 inches</i>			
<b>25 Runoff volume retention from street tree BMPs (ft<sup>3</sup>):</b> <i>V<sub>retention</sub> = Sum of Item 24 for all BMPs</i>			
<b>26 Implementation of residential rain barrels/cisterns:</b> <input type="checkbox"/> Yes <input checked="" type="checkbox"/> No <i>If yes, complete Items 27-28; If no, proceed to Item 30</i>			
<b>BMP Type and DA</b>	<b>BMP Type and DA</b>	<b>BMP Type and DA</b>	<b>BMP Type and DA</b>
<b>27 Number of rain barrels/cisterns</b>			
<b>28 Runoff volume retention from rain barrels/cisterns (ft<sup>3</sup>)</b> <i>V<sub>retention</sub> = Item 27 * 3</i>			
<b>29 Runoff volume retention from residential rain barrels/Cisterns (ft<sup>3</sup>):</b> <i>V<sub>retention</sub> = Sum of Item 28 for all BMPs</i>			
<b>30 Total Retention Volume from Site Design Hydrologic Source Control BMPs:</b> <i>Sum of Items 5, 13, 20, 25 and 29</i>			

### **4.3.2 Infiltration BMPs**

Use Form 4.3-3 to compute on-site retention of runoff from proposed retention and infiltration BMPs. Volume retention estimates are sensitive to the percolation rate used, which determines the amount of runoff that can be infiltrated within the specified drawdown time. The infiltration safety factor reduces field measured percolation to account for potential inaccuracy associated with field measurements, declining BMP performance over time, and compaction during construction. Appendix D of the TGD for WQMP provides guidance on estimating an appropriate safety factor to use in Form 4.3-3.

If site constraints limit the use of BMPs to a single type and implementation of retention and infiltration BMPs mitigate no more than 40% of the DCV, then they are considered infeasible and the Project Proponent may evaluate the effectiveness of BMPs lower in the LID hierarchy of use (Section 5.5.1 of the TGD for WQMP)

If implementation of infiltrations BMPs is feasible as determined using Form 4.3-1, then LID infiltration BMPs shall be implemented to the MEP (section 4.1 of the TGD for WQMP).

## Form 4.3-3 Infiltration LID BMP (including underground BMPs) (DMA 1)

<b><sup>1</sup> Remaining LID DCV not met by site design HSC BMP (ft<sup>3</sup>): 66,645</b> <i>V = Form 4.2-1 Item 7 - Form 4.3-2 Item 30</i>			
<b>BMP Type</b> <i>Use columns to the right to compute runoff volume retention from proposed infiltration BMP (select BMP from Table 5-4 in TGD for WQMP)</i>	<b>Infiltration Chambers</b>	n/a	n/a
<b><sup>2</sup> Infiltration rate of underlying soils (in/hr)</b> <i>See Section 5.4.2 and Appendix D of the TGD for WQMP for minimum requirements for assessment methods</i>	5.7	n/a	n/a
<b><sup>3</sup> Infiltration safety factor</b> <i>See TGD Section 5.4.2 and Appendix D</i>	2.0	n/a	n/a
<b><sup>4</sup> Design percolation rate (in/hr)</b> <i>P<sub>design</sub> = Item 2 / Item 3</i>	2.85	n/a	n/a
<b><sup>5</sup> Poned water drawdown time (hr)</b> <i>Copy Item 6 in Form 4.2-1</i>	48	n/a	n/a
<b><sup>6</sup> Maximum ponding depth (ft)</b> <i>BMP specific, see Table 5-4 of the TGD for WQMP for BMP design details</i>	5.15 (61.8 inches)	n/a	n/a
<b><sup>7</sup> Ponding Depth (ft)</b> <i>d<sub>BMP</sub> = Minimum of (1/12 * Item 4 * Item 5) or Item 6</i>	5.15 (61.8 inches)	n/a	n/a
<b><sup>8</sup> Infiltrating surface area, SA (ft<sup>2</sup>)</b> <i>The lesser of the area needed for BMP infiltration of full DCV or minimum space requirements from Table 5-7 of the TGD for WQMP</i>	16,409	n/a	n/a
<b><sup>9</sup> Amended soil depth, d<sub>media</sub> (ft)</b> <i>Only included in certain BMP types, see Table 5-4 in the TGD for WQMP for reference to BMP design details</i>	n/a	n/a	n/a
<b><sup>10</sup> Amended soil porosity</b>	n/a	n/a	n/a
<b><sup>11</sup> Gravel depth, d<sub>media</sub> (ft)</b> <i>Only included in certain BMP types, see Table 5-4 of the TGD for WQMP for BMP design details</i>	2.5	n/a	n/a
<b><sup>12</sup> Gravel porosity</b>	n/a	n/a	n/a
<b><sup>13</sup> Duration of storm as basin is filling (hrs)</b> <i>Typical ~ 3hrs</i>	n/a	n/a	n/a
<b><sup>14</sup> Above Ground Retention Volume (ft<sup>3</sup>)</b> <i>V<sub>retention</sub> = Item 8 * [Item 7 + (Item 9 retention * Item 10) + (Item 11 * Item 12) + (Item 13 * (Item 4 / 12))]</i>	n/a	n/a	n/a
<b><sup>15</sup> Underground Retention Volume (ft<sup>3</sup>)</b> <i>Volume determined using manufacturer's specifications and calculations</i>	66,799	n/a	n/a
<b><sup>16</sup> Total Retention Volume from LID Infiltration BMPs (ft<sup>3</sup>): 66,799</b> <i>(Sum of Items 14 and 15 for all infiltration BMP included in plan)</i>			
<b><sup>17</sup> Fraction of DCV achieved with infiltration BMP: 100%</b> <i>Retention% = Item 16 / Form 4.2-1 Item 7</i>			
<b><sup>18</sup> Is full LID DCV retained on-site with combination of hydrologic source control and LID retention and infiltration BMPs?</b> <input checked="" type="checkbox"/> Yes <input type="checkbox"/> No <i>If yes, demonstrate conformance using Form 4.3-10; If no, then reduce Item 3, Factor of Safety to 2.0 and increase Item 8, Infiltrating Surface Area, such that the portion of the site area used for retention and infiltration BMPs equals or exceeds the minimum effective area thresholds (Table 5-7 of the TGD for WQMP) for the applicable category of development and repeat all above calculations.</i>			

### 4.3.3 Harvest and Use BMP

Harvest and use BMP may be considered if the full LID DCV cannot be met by maximizing infiltration BMPs. Use Form 4.3-4 to compute on-site retention of runoff from proposed harvest and use BMPs.

Volume retention estimates for harvest and use BMPs are sensitive to the on-site demand for captured stormwater. Since irrigation water demand is low in the wet season, when most rainfall events occur in San Bernardino County, the volume of water that can be used within a specified drawdown period is relatively low. The bottom portion of Form 4.3-4 facilitates the necessary computations to show infeasibility if a minimum incremental benefit of 40 percent of the LID DCV would not be achievable with MEP implementation of on-site harvest and use of stormwater (Section 5.5.4 of the TGD for WQMP).

<b>Form 4.3-4 Harvest and Use BMPs</b>			
<sup>1</sup> Remaining LID DCV not met by site design HSC or infiltration BMP (ft <sup>3</sup> ): $V_{unmet} = \text{Form 4.2-1 Item 7} - \text{Form 4.3-2 Item 30} - \text{Form 4.3-3 Item 16}$			
<b>BMP Type(s)</b> <i>Compute runoff volume retention from proposed harvest and use BMP (Select BMPs from Table 5-4 of the TGD for WQMP)</i>	<b>BMP Type and DA</b>	<b>BMP Type and DA</b>	<b>BMP Type and DA</b>
<sup>2</sup> Describe cistern or runoff detention facility	n/a	n/a	n/a
<sup>3</sup> Storage volume for proposed detention type (ft <sup>3</sup> ) <i>Volume of cistern</i>	n/a	n/a	n/a
<sup>4</sup> Landscaped area planned for use of harvested stormwater (ft <sup>2</sup> )	n/a	n/a	n/a
<sup>5</sup> Average wet season daily irrigation demand (in/day) <i>Use local values, typical ~ 0.1 in/day</i>	n/a	n/a	n/a
<sup>6</sup> Daily water demand (ft <sup>3</sup> /day) <i>Item 4 * (Item 5 / 12)</i>	n/a	n/a	n/a
<sup>7</sup> Drawdown time (hrs) <i>Copy Item 6 from Form 4.2-1</i>	n/a	n/a	n/a
<sup>8</sup> Retention Volume (ft <sup>3</sup> ) $V_{retention} = \text{Minimum of (Item 3) or (Item 6 * (Item 7 / 24))}$	n/a	n/a	n/a
<sup>9</sup> Total Retention Volume (ft <sup>3</sup> ) from Harvest and Use BMP: <i>Sum of Item 8 for all harvest and use BMP included in plan</i>			
<sup>10</sup> Is the full DCV retained with a combination of LID HSC, retention and infiltration, and harvest and use BMPs? <input type="checkbox"/> Yes <input checked="" type="checkbox"/> No <i>If yes, demonstrate conformance using Form 4.3-10. If no, then re-evaluate combinations of all LID BMP and optimize their implementation such that the maximum portion of the DCV is retained on-site (using a single BMP type or combination of BMP types). If the full DCV cannot be mitigated after this optimization process, proceed to Section 4.3.4.</i>			

**4.3.4 Biotreatment BMP**

Biotreatment BMPs may be considered if the full LID DCV cannot be met by maximizing retention and infiltration, and harvest and use BMPs. A key consideration when using biotreatment BMP is the effectiveness of the proposed BMP in addressing the pollutants of concern for the project (see Table 5-5 of the TGD for WQMP).

Use Form 4.3-5 to summarize the potential for volume based and/or flow based biotreatment options to biotreat the remaining unmet LID DCV. Biotreatment computations are included as follows:

- Use Form 4.3-6 to compute biotreatment in small volume based biotreatment BMP (e.g. bioretention w/underdrains);
- Use Form 4.3-7 to compute biotreatment in large volume based biotreatment BMP (e.g. constructed wetlands);
- Use Form 4.3-8 to compute sizing criteria for flow-based biotreatment BMP (e.g. bioswales)

<b>Form 4.3-5 Selection and Evaluation of Biotreatment BMP</b>		
<sup>1</sup> Remaining LID DCV not met by site design HSC, infiltration, or harvest and use BMP for potential biotreatment (ft <sup>3</sup> ): <i>Form 4.2-1 Item 7 – Form 4.3-2 Item 30 – Form 4.3-3 Item 16- Form 4.3-4 Item 9</i>		List pollutants of concern <i>Copy from Form 2.3-1</i>
<sup>2</sup> Biotreatment BMP Selected <i>(Select biotreatment BMP(s) necessary to ensure all pollutants of concern are addressed through Unit Operations and Processes, described in Table 5-5 of the TGD for WQMP)</i>	<b>Volume-based biotreatment</b> <i>Use Forms 4.3-6 and 4.3-7 to compute treated volume</i>	<b>Flow-based biotreatment</b> <i>Use Form 4.3-8 to compute treated volume</i>
	<input type="checkbox"/> Bioretention with underdrain <input type="checkbox"/> Planter box with underdrain <input type="checkbox"/> Constructed wetlands <input type="checkbox"/> Wet extended detention <input type="checkbox"/> Dry extended detention <input type="checkbox"/> Proprietary biotreatment (volume)	<input type="checkbox"/> Vegetated swale <input type="checkbox"/> Vegetated filter strip <input type="checkbox"/> Proprietary biotreatment (flow)
<sup>3</sup> Volume biotreated in volume based biotreatment BMP (ft <sup>3</sup> ): <i>Form 4.3-6 Item 15 + Form 4.3-7 Item 13</i>	<sup>4</sup> Compute remaining LID DCV with implementation of volume based biotreatment BMP (ft <sup>3</sup> ): <i>Item 1 – Item 3</i>	<sup>5</sup> Remaining fraction of LID DCV for sizing flow based biotreatment BMP: <i>Item 4 / Item 1</i>
<sup>6</sup> Flow-based biotreatment BMP capacity provided (cfs): <i>Use Figure 5-2 of the TGD for WQMP to determine flow capacity required to provide biotreatment of remaining percentage of unmet LID DCV (Item 5), for the project's precipitation zone (Form 3-1 Item 1)</i>		
<sup>7</sup> Metrics for MEP determination: <input type="checkbox"/> Provided a WQMP with the portion of site area used for suite of LID BMP equal to minimum thresholds in Table 5-7 of the TGD for WQMP for the proposed category of development: <i>If maximized on-site retention BMPs is feasible for partial capture, then LID BMP implementation must be optimized to retain and infiltrate the maximum portion of the DCV possible within the prescribed minimum effective area. The remaining portion of the DCV shall then be mitigated using biotreatment BMP.</i>		

**Water Quality Management Plan (WQMP)  
Yorba Avenue Industrial Development**

**Form 4.3-6 Volume Based Biotreatment – Bioretention and Planter Boxes with Underdrains**

<b>BMP Type(s)</b> <i>Compute runoff volume retention from proposed harvest and use BMP (Select BMPs from Table 5-4 of the TGD for WQMP)</i>		
<b><sup>1</sup> Pollutants addressed with BMP</b> <i>List all pollutant of concern that will be effectively reduced through specific Unit Operations and Processes described in Table 5-5 of the TGD for WQMP</i>		
<b><sup>2</sup> Amended soil infiltration rate</b> <i>Typical ~ 5.0 in/hr</i>		
<b><sup>3</sup> Amended soil infiltration safety factor</b> <i>Typical ~ 2.0</i>		
<b><sup>4</sup> Amended soil design percolation rate (in/hr)</b> <i><math>P_{design} = \text{Item 2} / \text{Item 3}</math></i>		
<b><sup>5</sup> Pondered water drawdown time (hr)</b> <i>Copy Item 6 from Form 4.2-1</i>		
<b><sup>6</sup> Maximum ponding depth (ft)</b> <i>See Table 5-6 of the TGD for WQMP for reference to BMP design details</i>		
<b><sup>7</sup> Ponding Depth (ft)</b> <i><math>d_{BMP} = \text{Minimum of } (1/12 * \text{Item 4} * \text{Item 5}) \text{ or Item 6}</math></i>		
<b><sup>8</sup> Amended soil surface area (ft<sup>2</sup>)</b>		
<b><sup>9</sup> Amended soil depth (ft)</b> <i>See Table 5-6 of the TGD for WQMP for reference to BMP design details</i>		
<b><sup>10</sup> Amended soil porosity, n</b>		
<b><sup>11</sup> Gravel depth (ft)</b> <i>See Table 5-6 of the TGD for WQMP for reference to BMP design details</i>		
<b><sup>12</sup> Gravel porosity, n</b>		
<b><sup>13</sup> Duration of storm as basin is filling (hrs)</b> <i>Typical ~ 3hrs</i>		
<b><sup>14</sup> Biotreated Volume (ft<sup>3</sup>)</b> <i><math>V_{biotreated} = \text{Item 8} * [( \text{Item 7} / 2 ) + ( \text{Item 9} * \text{Item 10} ) + ( \text{Item 11} * \text{Item 12} ) + ( \text{Item 13} * ( \text{Item 4} / 12 ) )]</math></i>		
<b><sup>15</sup> Total biotreated volume from bioretention and/or planter box with underdrains BMP:</b> <i>Sum of Item 14 for all volume-based BMPs included in this form</i>		

**Water Quality Management Plan (WQMP)  
Yorba Avenue Industrial Development**

**Form 4.3-7 Volume Based Biotreatment – Constructed Wetlands and  
Extended Detention**

Biotreatment BMP Type <i>Constructed wetlands, extended wet detention, extended dry detention, or other comparable proprietary BMP. If BMP includes multiple modules (e.g. forebay and main basin), provide separate estimates for storage and pollutants treated in each module.</i>	BMP Type and DA		BMP Type and DA		BMP Type and DA	
	Forebay	Basin	Forebay	Basin	Forebay	Basin
<b><sup>1</sup> Pollutants addressed with BMP forebay and basin</b> <i>List all pollutant of concern that will be effectively reduced through specific Unit Operations and Processes described in Table 5-5 of the TGD for WQMP</i>						
<b><sup>2</sup> Bottom width (ft)</b>						
<b><sup>3</sup> Bottom length (ft)</b>						
<b><sup>4</sup> Bottom area (ft<sup>2</sup>)</b> <i>A<sub>bottom</sub> = Item 2 * Item 3</i>						
<b><sup>5</sup> Side slope (ft/ft)</b>						
<b><sup>6</sup> Depth of storage (ft)</b>						
<b><sup>7</sup> Water surface area (ft<sup>2</sup>)</b> <i>A<sub>surface</sub> = (Item 2 + (2 * Item 5 * Item 6)) * (Item 3 + (2 * Item 5 * Item 6))</i>						
<b><sup>8</sup> Storage volume (ft<sup>3</sup>)</b> <i>For BMP with a forebay, ensure fraction of total storage is within ranges specified in BMP specific fact sheets, see Table 5-6 of the TGD for WQMP for reference to BMP design details V = Item 6 / 3 * [Item 4 + Item 7 + (Item 4 * Item 7)<sup>0.5</sup>]</i>						
<b><sup>9</sup> Drawdown Time (hrs)</b> <i>Copy Item 6 from Form 2.1</i>						
<b><sup>10</sup> Outflow rate (cfs)</b> <i>Q<sub>BMP</sub> = (Item 8<sub>forebay</sub> + Item 8<sub>basin</sub>) / (Item 9 * 3600)</i>						
<b><sup>11</sup> Duration of design storm event (hrs)</b>						
<b><sup>12</sup> Biotreated Volume (ft<sup>3</sup>)</b> <i>V<sub>biotreated</sub> = (Item 8<sub>forebay</sub> + Item 8<sub>basin</sub>) + (Item 10 * Item 11 * 3600)</i>						
<b><sup>13</sup> Total biotreated volume from constructed wetlands, extended dry detention, or extended wet detention:</b> <i>(Sum of Item 12 for all BMP included in plan)</i>						

**Water Quality Management Plan (WQMP)  
Yorba Avenue Industrial Development**

<b>Form 4.3-8 Flow Based Biotreatment</b>			
<b>Biotreatment BMP Type</b> <i>Vegetated swale, vegetated filter strip, or other comparable proprietary BMP</i>	<b>BMP Type and DA</b>	<b>BMP Type and DA</b>	<b>BMP Type and DA</b>
<b><sup>1</sup> Pollutants addressed with BMP</b> <i>List all pollutant of concern that will be effectively reduced through specific Unit Operations and Processes described in TGD Table 5-5</i>			
<b><sup>2</sup> Flow depth for water quality treatment (ft)</b> <i>BMP specific, see Table 5-6 of the TGD for WQMP for reference to BMP design details</i>			
<b><sup>3</sup> Bed slope (ft/ft)</b> <i>BMP specific, see Table 5-6 of the TGD for WQMP for reference to BMP design details</i>			
<b><sup>4</sup> Manning's roughness coefficient</b>			
<b><sup>5</sup> Bottom width (ft)</b> <i><math>b_w = (\text{Form 4.3-5 Item 6} * \text{Item 4}) / (1.49 * \text{Item 2}^{1.67} * \text{Item 3}^{0.5})</math></i>			
<b><sup>6</sup> Side Slope (ft/ft)</b> <i>BMP specific, see Table 5-6 of the TGD for WQMP for reference to BMP design details</i>			
<b><sup>7</sup> Cross sectional area (ft<sup>2</sup>)</b> <i><math>A = (\text{Item 5} * \text{Item 2}) + (\text{Item 6} * \text{Item 2}^2)</math></i>			
<b><sup>8</sup> Water quality flow velocity (ft/sec)</b> <i><math>V = \text{Form 4.3-5 Item 6} / \text{Item 7}</math></i>			
<b><sup>9</sup> Hydraulic residence time (min)</b> <i>Pollutant specific, see Table 5-6 of the TGD for WQMP for reference to BMP design details</i>			
<b><sup>10</sup> Length of flow based BMP (ft)</b> <i><math>L = \text{Item 8} * \text{Item 9} * 60</math></i>			
<b><sup>11</sup> Water surface area at water quality flow depth (ft<sup>2</sup>)</b> <i><math>SA_{top} = (\text{Item 5} + (2 * \text{Item 2} * \text{Item 6})) * \text{Item 10}</math></i>			

### 4.3.5 Conformance Summary

Complete Form 4.3-9 to demonstrate how on-site LID DCV is met with proposed site design hydrologic source control, infiltration, harvest and use, and/or biotreatment BMP. The bottom line of the form is used to describe the basis for infeasibility determination for on-site LID BMP to achieve full LID DCV, and provides methods for computing remaining volume to be addressed in an alternative compliance plan. If the project has more than one outlet, then complete additional versions of this form for each outlet.

<b>Form 4.3-9 Conformance Summary and Alternative Compliance Volume Estimate (DMA 1)</b>	
<b><sup>1</sup> Total LID DCV for the Project (ft<sup>3</sup>):</b> 66,645	<i>Copy Item 7 in Form 4.2-1</i>
<b><sup>2</sup> On-site retention with site design hydrologic source control LID BMP (ft<sup>3</sup>):</b> 0	<i>Copy Item 30 in Form 4.3-2</i>
<b><sup>3</sup> On-site retention with LID infiltration BMP (ft<sup>3</sup>):</b> 66,799	<i>Copy Item 16 in Form 4.3-3</i>
<b><sup>4</sup> On-site retention with LID harvest and use BMP (ft<sup>3</sup>):</b> 0	<i>Copy Item 9 in Form 4.3-4</i>
<b><sup>5</sup> On-site biotreatment with volume based biotreatment BMP (ft<sup>3</sup>):</b> 0	<i>Copy Item 3 in Form 4.3-5</i>
<b><sup>6</sup> Flow capacity provided by flow based biotreatment BMP (cfs):</b> 0	<i>Copy Item 6 in Form 4.3-5</i>
<b><sup>7</sup> LID BMP performance criteria are achieved if answer to any of the following is "Yes":</b>	
<ul style="list-style-type: none"> <li>• <b>Full retention of LID DCV with site design HSC, infiltration, or harvest and use BMP:</b> <input checked="" type="checkbox"/>Yes <input type="checkbox"/>No <i>If yes, sum of Items 2, 3, and 4 is greater than Item 1</i></li> <li>• <b>Combination of on-site retention BMPs for a portion of the LID DCV and volume-based biotreatment BMP that address all pollutants of concern for the remaining LID DCV:</b> <input type="checkbox"/>Yes <input checked="" type="checkbox"/>No <i>If yes, a) sum of Items 2, 3, 4, and 5 is greater than Item 1, and Items 2, 3 and 4 are maximized; or b) Item 6 is greater than Form 4.3-5 Item 6 and Items 2, 3 and 4 are maximized</i></li> <li>• <b>On-site retention and infiltration is determined to be infeasible and biotreatment BMP provide biotreatment for all pollutants of concern for full LID DCV:</b> <input type="checkbox"/>Yes <input checked="" type="checkbox"/>No <i>If yes, Form 4.3-1 Items 7 and 8 were both checked yes</i></li> </ul>	
<b><sup>8</sup> If the LID DCV is not achieved by any of these means, then the project may be allowed to develop an alternative compliance plan. Check box that describes the scenario which caused the need for alternative compliance:</b>	
<input type="checkbox"/> <b>Combination of HSC, retention and infiltration, harvest and use, and biotreatment BMPs provide less than full LID DCV capture.</b> <i>Checked yes for Form 4.3-5 Item 7, Item 6 is zero, and sum of Items 2, 3, 4, and 5 is less than Item 1. If so, apply water quality credits and calculate volume for alternative compliance, <math>V_{alt} = (Item\ 1 - Item\ 2 - Item\ 3 - Item\ 4 - Item\ 5) * (100 - Form\ 2.4-1\ Item\ 2)\%</math></i>	
<input type="checkbox"/> <b>An approved Watershed Action Plan (WAP) demonstrates that water quality and hydrologic impacts of urbanization are more effective when managed in at an off-site facility.</b> <i>Attach appropriate WAP section, including technical documentation, showing effectiveness comparisons for the project site and regional watershed</i>	

### 4.3.6 Hydromodification Control BMP

Use Form 4.3-10 to compute the remaining runoff volume retention, after LID BMP are implemented, needed to address HCOC, and the increase in time of concentration and decrease in peak runoff necessary to meet targets for protection of waterbodies with a potential HCOC. Describe hydromodification control BMP that address HCOC, which may include off-site BMP and/or in-stream controls. Section 5.6 of the TGD for WQMP provides additional details on selection and evaluation of hydromodification control BMP.

<b>Form 4.3-10 Hydromodification Control BMPs</b>	
<p><sup>1</sup> <b>Volume reduction needed for HCOC performance criteria (ft<sup>3</sup>):</b> 64,724 <i>(Form 4.2-2 Item 4 * 0.95) – Form 4.2-2 Item 1</i></p>	<p><sup>2</sup> <b>On-site retention with site design hydrologic source control, infiltration, and harvest and use LID BMP (ft<sup>3</sup>):</b> 66,799 <i>Sum of Form 4.3-9 Items 2, 3, and 4. Evaluate option to increase implementation of on-site retention in Forms 4.3-2, 4.3-3, and 4.3-4 in excess of LID DCV toward achieving HCOC volume reduction</i></p>
<p><sup>3</sup> <b>Remaining volume for HCOC volume capture (ft<sup>3</sup>):</b> 0 <i>Item 1 – Item 2</i></p>	<p><sup>4</sup> <b>Volume capture provided by incorporating additional on-site or off-site retention BMPs (ft<sup>3</sup>):</b> 0 <i>Existing downstream BMP may be used to demonstrate additional volume capture (if so, attach to this WQMP a hydrologic analysis showing how the additional volume would be retained during a 2-yr storm event for the regional watershed)</i></p>
<p><sup>5</sup> <b>If Item 4 is less than Item 3, incorporate in-stream controls on downstream waterbody segment to prevent impacts due to hydromodification:</b> <i>Attach in-stream control BMP selection and evaluation to this WQMP</i></p>	
<p><sup>6</sup> <b>Is Form 4.2-2 Item 11 less than or equal to 5%:</b> <input type="checkbox"/>Yes <input checked="" type="checkbox"/>No <i>If yes, HCOC performance criteria is achieved. If no, select one or more mitigation options below:</i></p> <p><input checked="" type="checkbox"/> <b>Demonstrate increase in time of concentration achieved by proposed LID site design, LID BMP, and additional on-site or off-site retention BMP.</b> <i>BMP upstream of a waterbody segment with a potential HCOC may be used to demonstrate increased time of concentration through hydrograph attenuation (if so, show that the hydraulic residence time provided in BMP for a 2-year storm event is equal or greater than the addition time of concentration requirement in Form 4.2-4 Item 15)</i></p> <p><input type="checkbox"/> <b>Increase time of concentration by preserving pre-developed flow path and/or increase travel time by reducing slope and increasing cross-sectional area and roughness for proposed on-site conveyance facilities.</b></p> <p><input type="checkbox"/> <b>Incorporate appropriate in-stream controls for downstream waterbody segment to prevent impacts due to hydromodification, in a plan approved and signed by a licensed engineer in the State of California.</b></p>	
<p><sup>7</sup> <b>Form 4.2-2 Item 12 less than or equal to 5%:</b> <input type="checkbox"/>Yes <input checked="" type="checkbox"/>No <i>If yes, HCOC performance criteria are achieved. If no, select one or more mitigation options below:</i></p> <p><input checked="" type="checkbox"/> <b>Demonstrate reduction in peak runoff achieved by proposed LID site design, LID BMPs, and additional on-site or off-site retention BMPs.</b> <i>BMPs upstream of a waterbody segment with a potential HCOC may be used to demonstrate additional peak runoff reduction through hydrograph attenuation (if so, attach to this WQMP, a hydrograph analysis showing how the peak runoff would be reduced during a 2-yr storm event)</i></p> <p><input type="checkbox"/> <b>Incorporate appropriate in-stream controls for downstream waterbody segment to prevent impacts due to hydromodification, in a plan approved and signed by a licensed engineer in the State of California.</b></p>	

To meet HCOC requirements, a mitigation volume must be achieved by using LID and/or hydromodification mitigation BMPs. The mitigation volume is approximately 64,724 cu-ft ((0.95 \* 109,736) – 39,525). The total volume being detained/retained is 66,799 cu-ft which is greater than the mitigation volume needed. As a result, the mitigation volume has been contained by the proposed BMPs. Since the mitigation volume has been met, it is physically impossible for the project to avoid increasing the time of concentration and reducing peak runoff by more than five percent of pre-development conditions (see Section 5.6.1 of the Technical Guidance Document for more information).

## 4.4 Alternative Compliance Plan (if applicable)

Describe an alternative compliance plan (if applicable) for projects not fully able to infiltrate, harvest and use, or biotreat the DCV via on-site LID practices. A project proponent must develop an alternative compliance plan to address the remainder of the LID DCV. Depending on project type some projects may qualify for water quality credits that can be applied to reduce the DCV that must be treated prior to development of an alternative compliance plan (see Form 2.4-1, Water Quality Credits). Form 4.3-9 Item 8 includes instructions on how to apply water quality credits when computing the DCV that must be met through alternative compliance. Alternative compliance plans may include one or more of the following elements:

- On-site structural treatment control BMP - All treatment control BMP should be located as close to possible to the pollutant sources and should not be located within receiving waters;
- Off-site structural treatment control BMP - Pollutant removal should occur prior to discharge of runoff to receiving waters;
- Urban runoff fund or In-lieu program, if available

Depending upon the proposed alternative compliance plan, approval by the executive officer may or may not be required (see Section 6 of the TGD for WQMP).

## Section 5 Inspection and Maintenance Responsibility for Post Construction BMP

All BMP included as part of the project WQMP are required to be maintained through regular scheduled inspection and maintenance (refer to Section 8, Post Construction BMP Requirements, in the TGD for WQMP). Fully complete Form 5-1 summarizing all BMP included in the WQMP. Attach additional forms as needed. The WQMP shall also include a detailed Operation and Maintenance Plan for all BMP and may require a Maintenance Agreement (consult the jurisdiction's LIP). If a Maintenance Agreement is required, it must also be attached to the WQMP.

<b>Form 5-1 BMP Inspection and Maintenance</b>			
<b>BMP</b>	<b>Responsible Party(ies)</b>	<b>Inspection/Maintenance Activities Required</b>	<b>Minimum Frequency of Activities</b>
Storm Drain Stenciled Message	Owner	Visually inspect for legibility and replace or repaint as necessary.	Annually and repaint as needed
Underground Chambers	Owner	The isolator rows shall be inspected and maintained by a qualified technician using a 'JetVac' device and he/she will properly dispose of all wastes and inspect for standing water. A manhole is installed in order to inspect and maintain the inlet row. All entry into the chamber system must be done per OSHA codes to ensure operator and inspector safety.	The isolator rows shall be inspected semi-annually (by October 1st and February 1st) and cleaned by water-flush and vacuum when solids accumulate to 3" depth. Maintenance to be conducted through service contract with the vendor or equally qualified contractor.
Hydrodynamic Separator	Owner	System shall be inspected at regular intervals and maintained when necessary to ensure optimum performance. Systems should be cleaned when inspection reveals that accumulated sediment or trash is clogging the discharge orifice or sediment/debris accumulation has exceeded 25% of storage capacity in the grit chamber and behind the floating debris screen. All appropriate precautions regarding confined space entry and OSHA regulations should be followed.	Quarterly through maintenance service contract with the vendor or equally qualified contractor.
Parking Lot Sweeping	Owner	Sweep all paved areas for vehicle traffic with industrial vacuum sweeper.	Monthly (minimum)

**Water Quality Management Plan (WQMP)  
Yorba Avenue Industrial Development**

<p>N3: Landscape Management BMPs</p>	<p>Owner</p>	<p>Maintenance shall be conducted by a landscape contractor on a weekly basis to verify that the irrigation system is functioning properly and to repair as needed. Landscape contractor will also verify that there are no leaks or run-off from landscaped areas. Adjust irrigation heads and system run times as necessary to prevent overwatering of vegetation, overspray or run-off from landscaped areas to ensure the health and aesthetic quality of the landscape. Mowing and trimming waste shall be properly removed from the site and herbicides, pesticides and fertilizers shall be properly applied to prevent storm drainage contamination.</p>	<p>Weekly</p>
<p>S4: Use efficient irrigation systems &amp; landscape design, water conservation, smart controllers, and source control (Statewide Model Landscape Ordinance; CASQA New Development BMP Handbook SD-12)</p>	<p>Owner</p>	<p>Implementation frequency: Maintenance shall be provided weekly to check and repair the irrigation system proper functioning and verify there are no leaks or run-off from landscaped areas. Adjust irrigation heads and system controller as necessary to prevent overwatering of vegetation, overspray or run-off from landscape areas and to ensure the health and aesthetic quality of the landscape.</p>	<p>Weekly</p>
<p>S3: Design and construct trash and waste storage areas to reduce pollution introduction (CASQA New Development BMP Handbook SD-32)</p>	<p>Owner</p>	<p>Trash enclosures shall be roofed with a solid canopy style roof and paved with an impervious surface, designed not to allow run-on from adjoining areas, designed to divert drainage from adjoining roofs and pavements around the area, and screened or walled to prevent off-site transport of trash.</p>	<p>Weekly</p>

## Section 6 WQMP Attachments

### 6.1 Site Plan and Drainage Plan

Attachments include:

- Attachment A – Existing Condition Site Photos
- Attachment B – BMP Design Calculations & Supporting Documentation
- Attachment C – WQMP Site Map
  - Include a site plan and drainage plan sheet set containing the following minimum information:
    - Project location
    - Site boundary
    - Land uses and land covers, as applicable
    - Suitability/feasibility constraints
    - Structural Source Control BMP locations
    - Site Design Hydrologic Source Control BMP locations
    - LID BMP details
    - Drainage delineations and flow information
    - Drainage connections

**Attachment A**  
**Existing Condition Site Photos**





**Attachment B**  
**BMP Design Calculations & Supporting**  
**Documentation**



**NOAA Atlas 14, Volume 6, Version 2**  
**Location name: Chino, California, USA\***  
**Latitude: 34.0058°, Longitude: -117.7034°**  
**Elevation: m/ft\*\***  
 \* source: ESRI Maps  
 \*\* source: USGS



**POINT PRECIPITATION FREQUENCY ESTIMATES**

Sanja Perica, Sarah Dietz, Sarah Heim, Lillian Hiner, Kazungu Maitaria, Deborah Martin, Sandra Pavlovic, Ishani Roy, Carl TrypaLuk, Dale Unruh, FengJin Yan, Michael Yekta, Tan Zhao, Geoffrey Bonnin, Daniel Brewer, Li-Chuan Chen, Tye Parzybok, John Yarchoan

NOAA, National Weather Service, Silver Spring, Maryland

[PF tabular](#) | [PF graphical](#) | [Maps & aerials](#)

**PF tabular**

<b>PDS-based point precipitation frequency estimates with 90% confidence intervals (in inches)<sup>1</sup></b>										
Duration	Average recurrence interval (years)									
	1	2	5	10	25	50	100	200	500	1000
5-min	0.117 (0.098-0.141)	0.152 (0.127-0.184)	0.200 (0.166-0.243)	0.240 (0.198-0.294)	0.296 (0.235-0.375)	0.340 (0.265-0.441)	0.386 (0.293-0.513)	0.434 (0.320-0.595)	0.502 (0.354-0.718)	0.596 (0.406-0.885)
10-min	0.167 (0.140-0.202)	0.218 (0.182-0.264)	0.287 (0.238-0.348)	0.344 (0.284-0.421)	0.424 (0.337-0.537)	0.487 (0.379-0.631)	0.553 (0.420-0.735)	0.622 (0.459-0.852)	0.719 (0.508-1.03)	0.855 (0.582-1.27)
15-min	0.202 (0.169-0.245)	0.264 (0.220-0.320)	0.347 (0.288-0.421)	0.416 (0.343-0.509)	0.512 (0.408-0.650)	0.589 (0.459-0.764)	0.668 (0.507-0.889)	0.752 (0.555-1.03)	0.870 (0.614-1.24)	1.03 (0.704-1.53)
30-min	0.304 (0.254-0.367)	0.396 (0.330-0.479)	0.520 (0.432-0.631)	0.623 (0.514-0.764)	0.768 (0.612-0.975)	0.883 (0.688-1.15)	1.00 (0.761-1.33)	1.13 (0.832-1.55)	1.30 (0.920-1.87)	1.55 (1.06-2.30)
60-min	0.456 (0.381-0.551)	0.594 (0.495-0.719)	0.780 (0.649-0.947)	0.935 (0.771-1.15)	1.15 (0.918-1.46)	1.33 (1.03-1.72)	1.50 (1.14-2.00)	1.69 (1.25-2.32)	1.96 (1.38-2.80)	2.33 (1.58-3.45)
2-hr	0.686 (0.573-0.830)	0.896 (0.747-1.09)	1.17 (0.969-1.42)	1.38 (1.14-1.69)	1.67 (1.33-2.12)	1.88 (1.47-2.44)	2.10 (1.60-2.80)	2.32 (1.71-3.18)	2.61 (1.84-3.74)	2.84 (1.93-4.21)
3-hr	0.872 (0.729-1.06)	1.14 (0.949-1.38)	1.47 (1.23-1.79)	1.74 (1.43-2.13)	2.09 (1.66-2.65)	2.35 (1.83-3.04)	2.60 (1.98-3.46)	2.86 (2.11-3.92)	3.20 (2.26-4.57)	3.45 (2.35-5.12)
6-hr	1.21 (1.01-1.46)	1.57 (1.31-1.90)	2.03 (1.68-2.46)	2.38 (1.96-2.92)	2.84 (2.26-3.61)	3.18 (2.48-4.13)	3.52 (2.67-4.68)	3.85 (2.84-5.27)	4.28 (3.02-6.12)	4.60 (3.13-6.82)
12-hr	1.59 (1.33-1.92)	2.06 (1.72-2.50)	2.67 (2.22-3.24)	3.15 (2.60-3.86)	3.79 (3.01-4.80)	4.26 (3.32-5.52)	4.73 (3.59-6.29)	5.20 (3.83-7.12)	5.82 (4.11-8.33)	6.29 (4.28-9.33)
24-hr	2.05 (1.81-2.36)	2.68 (2.37-3.09)	3.51 (3.09-4.06)	4.18 (3.65-4.88)	5.09 (4.31-6.13)	5.79 (4.80-7.12)	6.50 (5.26-8.19)	7.23 (5.70-9.36)	8.22 (6.22-11.1)	8.99 (6.57-12.5)
2-day	2.47 (2.19-2.85)	3.30 (2.91-3.81)	4.41 (3.89-5.11)	5.34 (4.67-6.23)	6.65 (5.63-8.01)	7.68 (6.37-9.45)	8.76 (7.09-11.0)	9.90 (7.80-12.8)	11.5 (8.69-15.5)	12.8 (9.33-17.8)
3-day	2.66 (2.35-3.07)	3.60 (3.18-4.15)	4.88 (4.30-5.65)	5.96 (5.21-6.96)	7.50 (6.35-9.04)	8.73 (7.24-10.7)	10.0 (8.12-12.6)	11.4 (9.00-14.8)	13.4 (10.1-18.0)	15.0 (10.9-20.9)
4-day	2.89 (2.55-3.33)	3.93 (3.48-4.54)	5.36 (4.72-6.21)	6.57 (5.74-7.66)	8.27 (7.00-9.97)	9.63 (7.98-11.8)	11.1 (8.95-13.9)	12.6 (9.91-16.3)	14.7 (11.1-19.9)	16.4 (12.0-22.9)
7-day	3.28 (2.91-3.79)	4.49 (3.97-5.18)	6.10 (5.37-7.06)	7.43 (6.50-8.67)	9.27 (7.85-11.2)	10.7 (8.89-13.2)	12.2 (9.88-15.4)	13.8 (10.8-17.8)	15.9 (12.0-21.5)	17.6 (12.9-24.6)
10-day	3.60 (3.19-4.15)	4.93 (4.36-5.69)	6.69 (5.89-7.74)	8.12 (7.11-9.48)	10.1 (8.54-12.2)	11.6 (9.63-14.3)	13.2 (10.7-16.6)	14.8 (11.7-19.2)	17.0 (12.9-22.9)	18.7 (13.7-26.1)
20-day	4.36 (3.86-5.03)	6.04 (5.34-6.98)	8.26 (7.28-9.56)	10.1 (8.81-11.8)	12.6 (10.6-15.1)	14.5 (12.0-17.8)	16.4 (13.3-20.7)	18.5 (14.6-23.9)	21.2 (16.1-28.7)	23.4 (17.1-32.7)
30-day	5.23 (4.63-6.03)	7.28 (6.43-8.40)	10.0 (8.83-11.6)	12.3 (10.7-14.3)	15.5 (13.1-18.6)	17.9 (14.9-22.1)	20.5 (16.6-25.8)	23.2 (18.3-30.1)	26.9 (20.4-36.4)	29.9 (21.9-41.7)
45-day	6.19 (5.48-7.14)	8.60 (7.60-9.93)	11.9 (10.5-13.8)	14.7 (12.9-17.2)	18.7 (15.9-22.6)	22.0 (18.2-27.0)	25.4 (20.6-32.0)	29.1 (22.9-37.7)	34.3 (26.0-46.3)	38.6 (28.2-53.8)
60-day	7.12 (6.30-8.20)	9.80 (8.66-11.3)	13.6 (12.0-15.7)	16.9 (14.8-19.7)	21.7 (18.4-26.2)	25.7 (21.3-31.7)	30.1 (24.3-37.9)	34.8 (27.4-45.1)	41.7 (31.5-56.2)	47.4 (34.7-66.2)

<sup>1</sup> Precipitation frequency (PF) estimates in this table are based on frequency analysis of partial duration series (PDS). Numbers in parenthesis are PF estimates at lower and upper bounds of the 90% confidence interval. The probability that precipitation frequency estimates (for a given duration and average recurrence interval) will be greater than the upper bound (or less than the lower bound) is 5%. Estimates at upper bounds are not checked against probable maximum precipitation (PMP) estimates and may be higher than currently valid PMP values. Please refer to NOAA Atlas 14 document for more information.

[Back to Top](#)

**PF graphical**

PDS-based depth-duration-frequency (DDF) curves  
 Latitude: 34.0058°, Longitude: -117.7034°

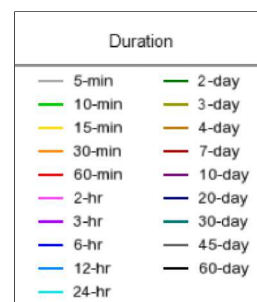
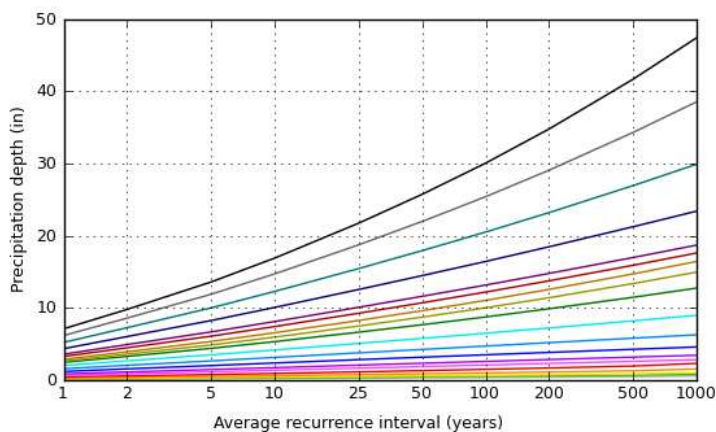
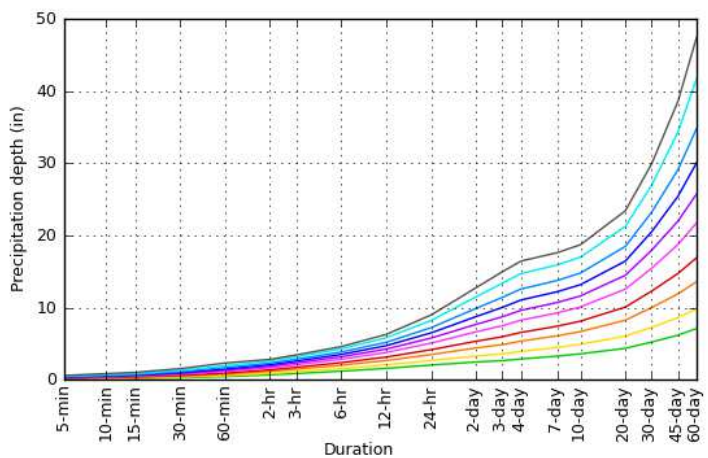

NOAA Atlas 14, Volume 6, Version 2

Created (GMT): Mon Mar 6 21:51:25 2023

[Back to Top](#)

Maps & aerials

Small scale terrain



Large scale terrain



### Large scale map



### Large scale aerial



[Back to Top](#)

---

[US Department of Commerce](#)  
[National Oceanic and Atmospheric Administration](#)  
[National Weather Service](#)  
[National Water Center](#)  
1325 East West Highway  
Silver Spring, MD 20910  
Questions?: [HDSC.Questions@noaa.gov](mailto:HDSC.Questions@noaa.gov)

[Disclaimer](#)

### Worksheet H: Factor of Safety and Design Infiltration Rate Worksheet

Factor Category		Factor Description	Assigned Weight (w)	Factor Value (v)	Product (p) $p = w \times v$
A	Suitability Assessment	Soil assessment methods	0.25	1	0.25
		Predominant soil texture	0.25	1	0.25
		Site soil variability	0.25	1	0.25
		Depth to groundwater / impervious layer	0.25	1	0.25
		Suitability Assessment Safety Factor, $S_A = \sum p$			
B	Design	Tributary area size	0.25	3	0.75
		Level of pretreatment/ expected sediment loads	0.25	1	0.25
		Redundancy	0.25	3	0.75
		Compaction during construction	0.25	1	0.25
		Design Safety Factor, $S_B = \sum p$			
Combined Safety Factor, $S_{TOT} = S_A \times S_B$				2.00	
Measured Infiltration Rate, inch/hr, $K_M$ (corrected for test-specific bias)				5.70	
Design Infiltration Rate, in/hr, $K_{DESIGN} = K_M / S_{TOT}$				2.85	

#### Supporting Data

Briefly describe infiltration test and provide reference to test forms:

A site-specific infiltration test was conducted at the BMP location to support a measured infiltration rate of 5.70 in/hr. The design rate is 2.85 in/hr after applying the appropriate safety factor. This design rate is suitable for infiltration facilities.

**Note:** The minimum combined adjustment factor shall not be less than 2.0 and the maximum combined adjustment factor shall not exceed 9.0.

## FLOW-BASED BMP DESIGN

$$C_{BMP} = 0.858(\text{imp})^3 - 0.78(\text{imp})^2 + 0.774(\text{imp}) + 0.04$$

$$I_{BMP} = (0.594)(0.2787)(2) = 0.331 \text{ in/hr}$$

$$Q = C_{BMP} * 0.331 * \text{Area}$$

### DMA 1 – HYDRODYNAMIC SEPARATOR

Region		Valley	
Drainage Area (acres)		13.17	acres
Drainage Area (sq-ft)		573,685	sq-ft
Impervious Coeff	i =	0.95	< 1.0
Runoff Coeff	C =	0.810	
<a href="#">1-hr 2-yr from NOAA</a>		0.594	
Intensity Coeff		0.2787	
Intensity BMP (in/hr)		0.331	
Flow (cfs)	Q =	3.53	

Use CDS4030-8 (80% @ 100 micron)

Q-required = 3.53 cfs

Q-provided = 3.84 cfs

# VOLUME-BASED BMP DESIGN

$$C_{BMP} = 0.858(\text{imp})^3 - 0.78(\text{imp})^2 + 0.774(\text{imp}) + 0.04$$

$$P6 = (0.594)(1.4807) = 0.880 \text{ inches}$$

$$P0 = (1.963)(C_{BMP})(0.880)$$

$$DCV = (P0 * \text{Area}) / 12$$

## DMA 1 – STORMTECH MC-3500 INFILTRATION CHAMBERS

Region	Valley	
Drainage Area (acres)	13.17	acres
Drainage Area (sq-ft)	573,685	sq-ft
Impervious Coeff	i = 0.95	< 1.0
Runoff Coeff	C = 0.807	
	1-hr 2-yr from NOAA	0.594
P6 Coeff	1.4807	
Mean 6-hr (P6)	0.880	
Drawdown Rate (a)	1.963	
DCV	66,645	cu-ft
DCV	1.530	acre-ft

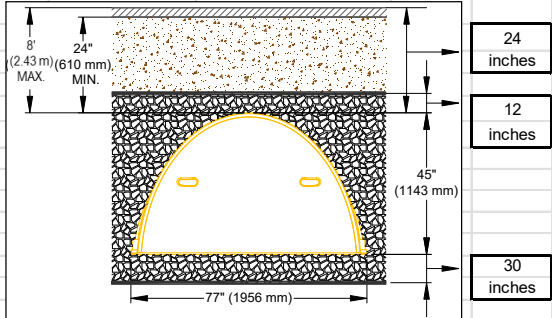
		<b>Project Information:</b> Project Name: Yorba Ave, Chino (TEI 4163) Location: Chino, CA Date: 9-Aug Engineer: Thienes Engineering StormTech RPM:	
		<b>MC-3500 Site Calculator</b>	
<b>System Requirements</b>		<b>System Sizing</b>	
Units	Imperial	Number of Chambers Required	307 each
Required Storage Volume	66645 CF	Number of End Caps Required	14 each
Stone Porosity (Industry Standard = 40%)	40 %	Bed Size (including perimeter stone)	16,409 square feet
Stone Above Chambers (12 inch min.)	12 inches	Stone Required (including perimeter stone)	4413 tons
Stone Foundation Depth (9 inch min.)	30 inches	Volume of Excavation	4406 cubic yards
Average Cover over Chambers (24 inch min.)	24 inches	Non-woven Filter Fabric Required (20% Safety Factor)	5094 square yards
Bed size controlled by WIDTH or LENGTH?	WIDTH	Length of Isolator Row	320.1 feet
Limiting WIDTH or LENGTH dimension	55 feet	Non-woven Isolator Row Fabric (20% Safety Factor)	555 square yards
Storage Volume per Chamber	214.9 CF	Woven Isolator Row Fabric (20% Safety Factor)	704 square yards
Storage Volume per End Cap	58.9 CF	Installed Storage Volume	66,799 cubic feet
<b>Controlled by Width (Rows)</b>			
Maximum Width =	55 feet		
6 rows of	44 chambers		
1 row of	43 chambers		
Maximum Length =	320.11 feet		
Maximum Width =	51.42 feet		
*This represents the estimated material and site work costs (US dollars) for the project. Materials excluded from this estimate are conveyance pipe, pavement design, etc. It is always advisable to seek detailed construction costs from local installers. Please contact STORMTECH at 888-892-2694 for additional cost information.			

Design infiltration rate = 2.85 in/hr

$$d_{\text{max}} = 136.8 \text{ inches} = \text{Design infiltration rate} \times 48 \text{ hours} = 2.85 \text{ in/hr} \times 48 \text{ hrs}$$

$$d_{BMP} = 61.8 \text{ inches} = [(12 \text{ inches} + 30 \text{ inches}) \times 0.40] + 45 \text{ inches}$$

$$d_{\text{max}} > d_{BMP}$$

# **Diversion Structure Orifice Calculations**

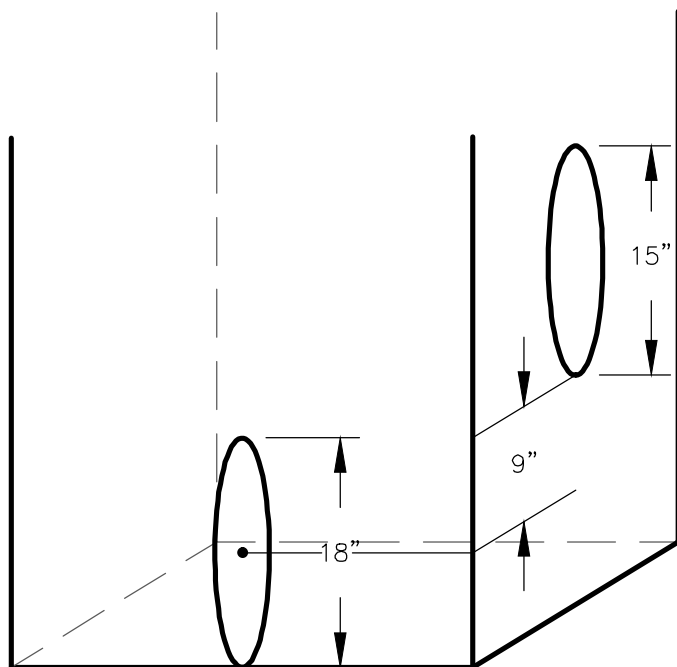

DIVERSION STRUCTURE #1  
NTS

FLOWRATE

TRIBUTARY AREA: 12.25 ACRES

$$Q \text{ (DIVERSION STRUCTURE \#1)} = 3.28 \text{ cfs}$$

ORIFICE EQUATION FOR DIVERSION STRUCTURE

$$Q = CA(2gh)^{\frac{1}{2}}$$

$$C = 0.6$$

$$A = 1.767 \text{ ft}^2 \text{ FOR } 18" \text{ PIPE}$$

$$g = 32.2 \text{ ft/s}^2$$

$$h = 0.75 \text{ ft}$$

$$Q = 0.6 * 1.767 * (2 * 32.2 * 0.75)^{\frac{1}{2}}$$

$$Q = 7.37 \text{ cfs}$$

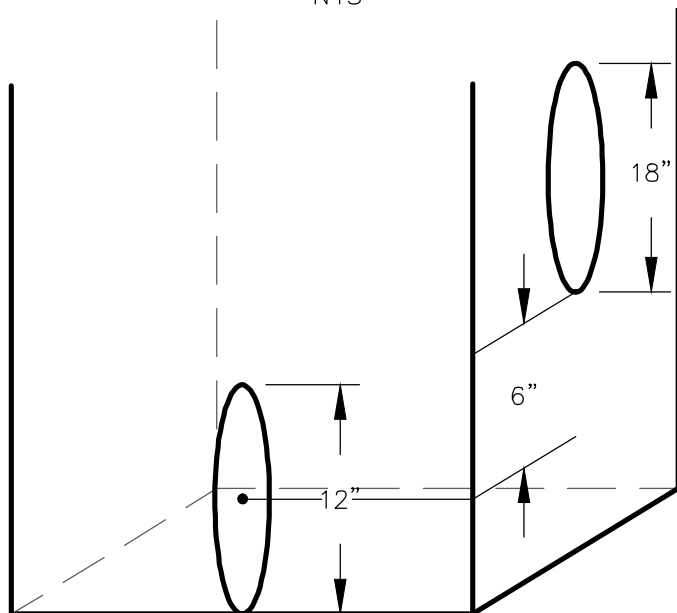

DIVERSION STRUCTURE #2  
NTS

FLOWRATE

TRIBUTARY AREA: 0.92 ACRES

$$Q \text{ (DIVERSION STRUCTURE \#2)} = 0.25 \text{ cfs}$$

ORIFICE EQUATION FOR DIVERSION STRUCTURE

$$Q = CA(2gh)^{\frac{1}{2}}$$

$$C = 0.6$$

$$A = 0.785 \text{ ft}^2 \text{ FOR } 12" \text{ PIPE}$$

$$g = 32.2 \text{ ft/s}^2$$

$$h = 0.50 \text{ ft}$$

$$Q = 0.6 * 0.785 * (2 * 32.2 * 0.50)^{\frac{1}{2}}$$

$$Q = 2.67 \text{ cfs}$$

Last Update: 9/7/23

O:\4100-4199\4163\WQMP\0) ORIFICE CALCULATIONS\41630rifice Calculations.dwg

Diversion Structure #1

Region	Valley	
Drainage Area (acres)	12.25	acres
Drainage Area (sq-ft)	533,610	sq-ft
Impervious Coeff	0.95	< 1.0
Runoff Coeff	0.810	
<a href="#">1-hr 2-yr from NOAA</a>	0.594	
Intensity Coeff	0.2787	
Intensity BMP (in/hr)	0.331	
Flow (cfs)	3.28	

Diversion Structure #2

Region	Valley	
Drainage Area (acres)	0.92	acres
Drainage Area (sq-ft)	40,075	sq-ft
Impervious Coeff	0.95	< 1.0
Runoff Coeff	0.810	
<a href="#">1-hr 2-yr from NOAA</a>	0.594	
Intensity Coeff	0.2787	
Intensity BMP (in/hr)	0.331	
Flow (cfs)	0.25	

i =

C =

Q =

**Attachment C**  
**WQMP Site Map**

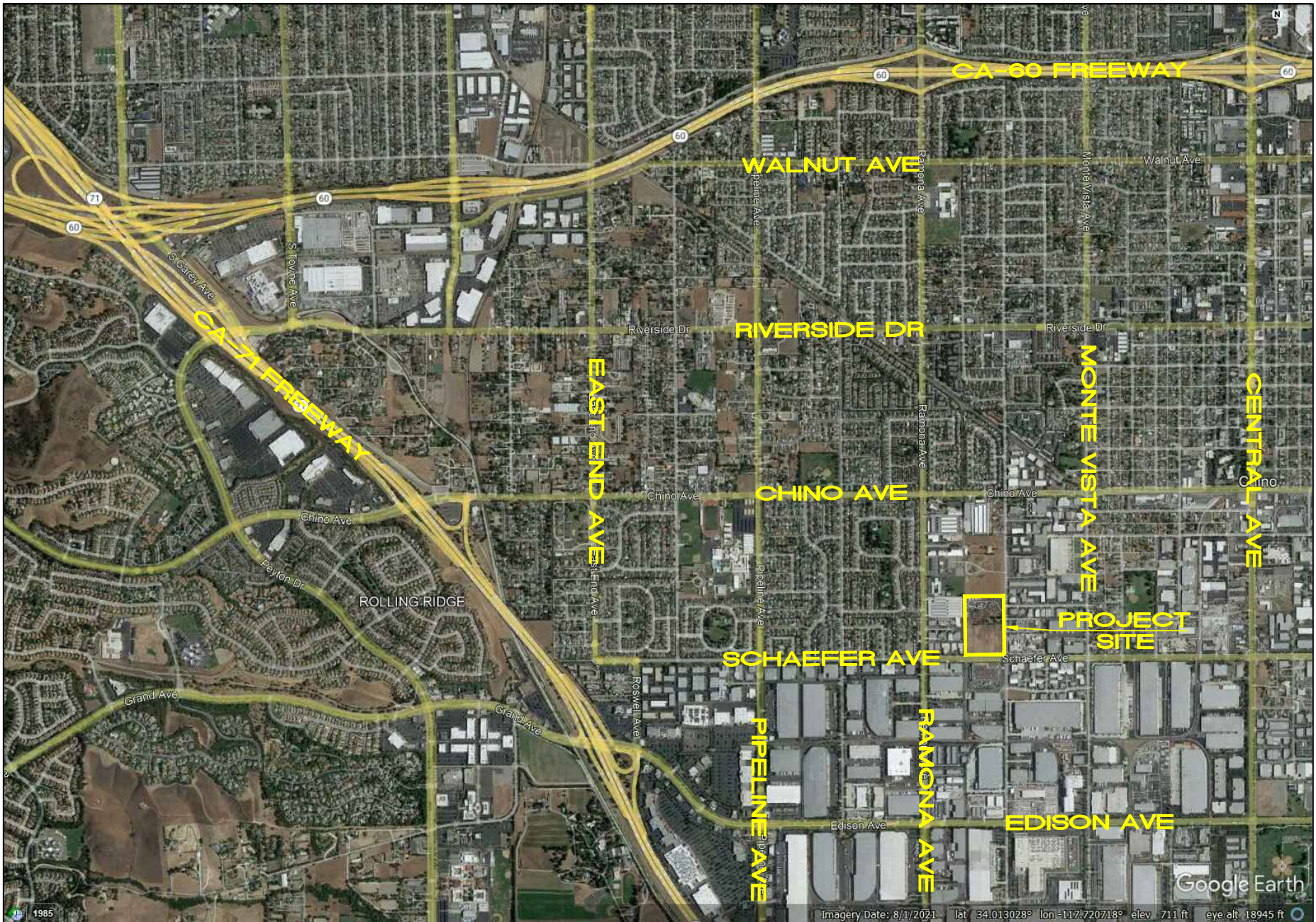

**TEI** Thienes Engineering, Inc.  
 CIVIL ENGINEERING • LAND SURVEYING  
 14349 FIRESTONE BOULEVARD  
 LA MIRADA, CALIFORNIA 90638  
 PH.(714)521-4811 FAX(714)521-4173

**VICINITY MAP**  
 FOR  
**YORBA AVENUE INDUSTRIAL DEVELOPMENT**  
**CHINO, CALIFORNIA**





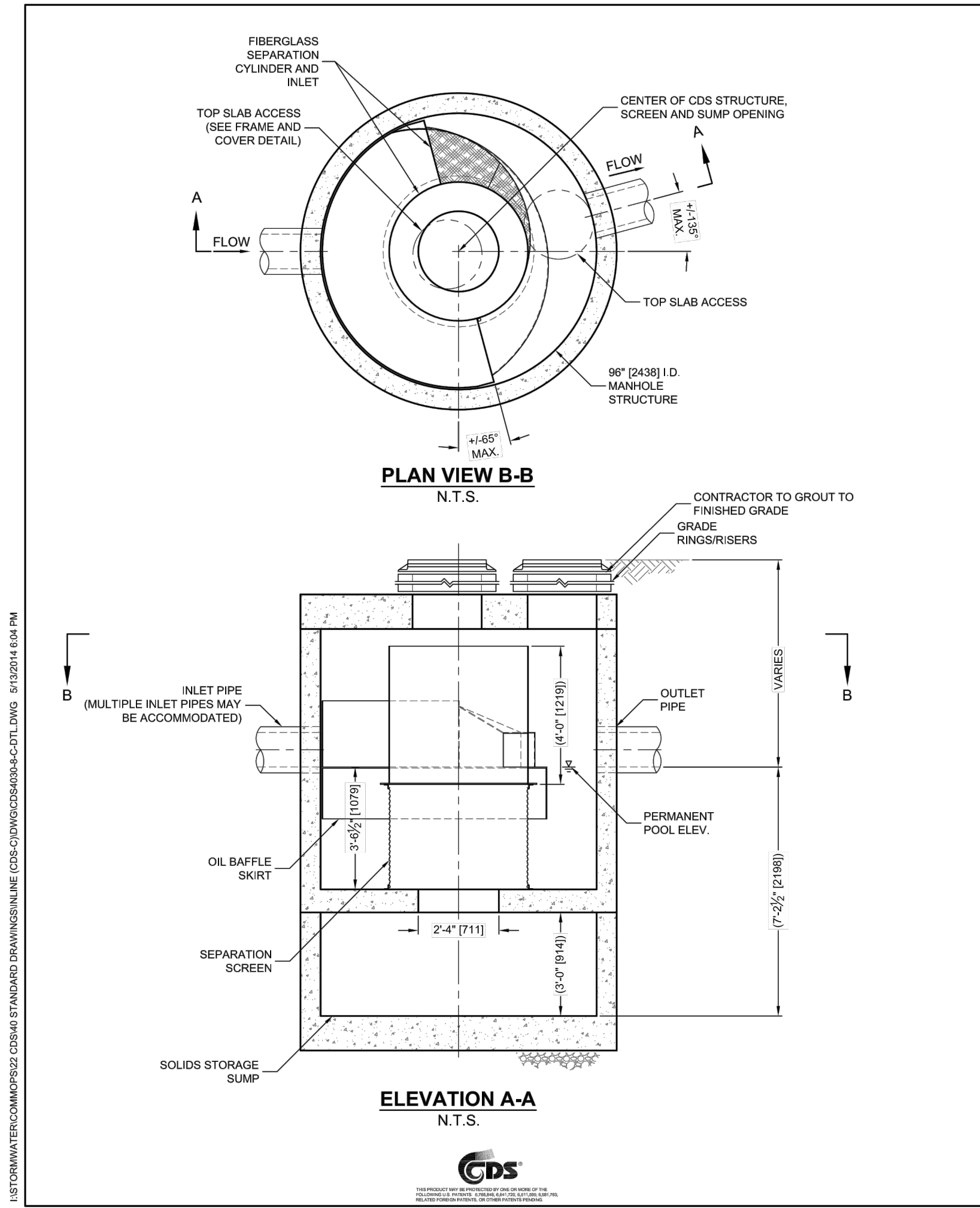

**CDS4030-8-C DESIGN NOTES**

CDS4030-8-C RATED TREATMENT CAPACITY IS 4.5 CFS (127.4 L/s), OR PER LOCAL REGULATIONS. MAXIMUM HYDRAULIC INTERNAL BYPASS CAPACITY IS 30.0 CFS (850 L/s). IF THE SITE CONDITIONS EXCEED 30.0 CFS (850 L/s), AN UPSTREAM BYPASS STRUCTURE IS REQUIRED.

THE STANDARD CDS4030-8-C CONFIGURATION IS SHOWN. ALTERNATE CONFIGURATIONS ARE AVAILABLE AND ARE LISTED BELOW. SOME CONFIGURATIONS MAY BE COMBINED TO SUIT SITE REQUIREMENTS.

**CONFIGURATION DESCRIPTION**

GRATED INLET ONLY (NO INLET PIPE)

GRATED INLET WITH INLET PIPE OR PIPES

CURB INLET ONLY (NO INLET PIPE)

CURB INLET WITH INLET PIPE OR PIPES

SEPARATE OIL BAFFLE (SINGLE INLET PIPE REQUIRED FOR THIS CONFIGURATION)

SEDIMENT WEIR FOR DEEP / FLAT CONFORMING UNITS

**SITE SPECIFIC DATA REQUIREMENTS**

STRUCTURE ID	DATE
WATER QUALITY FLOW RATE (GFS OR L/S)	*
PEAK FLOW RATE (GFS OR L/S)	*
RETURN PERIOD OF PEAK FLOW (YRS)	*
SCREEN APERTURE (200 OR 475)	*

**PIPE DATA**

INLET PIPE 1	INLET PIPE 2	OUTLET PIPE	DIAMETER
*	*	*	*

**ANTI FLOTATION BALLAST**

WIDTH	HEIGHT
*	*

NOTES/SPECIAL REQUIREMENTS:

\*PER ENGINEER OF RECORD

**GENERAL NOTES**

- CONTECH TO PROVIDE ALL MATERIALS UNLESS NOTED OTHERWISE.
- DIMENSIONS MARKED WITH L ARE REFERENCE DIMENSIONS. ACTUAL DIMENSIONS MAY VARY.
- FOR FABRICATION DRAWINGS WITH DETAILED STRUCTURE DIMENSIONS AND WEIGHTS, PLEASE CONTACT YOUR CONTECHENGINEERED SOLUTIONS LLC REPRESENTATIVE. [www.conteches.com](http://www.conteches.com)
- CDS WATER QUALITY STRUCTURE SHALL BE IN ACCORDANCE WITH ALL DESIGN DATA AND INFORMATION CONTAINED IN THIS DRAWING.
- STRUCTURE SHALL MEET AASHTO H20-44 AND AASHTO H19-44 LOAD RATINGS. ASSUMING GROUNDWATER ELEVATION AT, OR BELOW, THE OUTLET PIPE INVERT ELEVATION. ENGINEER OF RECORD TO CONFIRM ACTUAL GROUNDWATER ELEVATION.
- PVC HYDRAULIC BREAK PLATE IS PLACED ON SHELVE AT BOTTOM OF SCREEN CYLINDER. REMOVE AND REPLACE AS NECESSARY DURING MAINTENANCE CLEANING.

**INSTALLATION NOTES**

- ANY SUBSIDIARY BACKFILL DEPTH, AND/OR ANTI-FLOTATION PROVISIONS ARE SITE-SPECIFIC DESIGN CONSIDERATIONS AND SHALL BE SPECIFIED BY ENGINEER OF RECORD.
- CONTRACTOR TO PROVIDE EQUIPMENT WITH SUFFICIENT LIFTING AND REACH CAPACITY TO LIFT AND SET THE CDS MANHOLE STRUCTURE (LIFTING CLUTCHES PROVIDED).
- CONTRACTOR TO ADD JOINT SEALANT BETWEEN ALL STRUCTURE SECTIONS, AND ASSEMBLE STRUCTURE.
- CONTRACTOR TO PROVIDE, INSTALL, AND GROUT PIPES. MATCH PIPE INVERTS WITH ELEVATIONS SHOWN.
- CONTRACTOR TO TAKE APPROPRIATE MEASURES TO ASSURE UNIT IS WATER TIGHT, HOLDING WATER TO FLOWLINE INVERT MINIMUM. IT IS SUGGESTED THAT ALL JOINTS BELOW PIPE INVERTS ARE GROUTED.

**CONTECH ENGINEERED SOLUTIONS LLC**  
www.conteches.com  
2028 Centre Pointe Dr., Suite 100, West Chester, OH 45380  
937-738-1122 937-445-7000 937-445-7993 FAX

CDS4030-8-C  
INLINE CDS  
STANDARD DETAIL

# StormTech® MC-3500 Chamber

Designed to meet the most stringent industry performance standards for superior structural integrity while providing designers with a cost-effective method to save valuable land and protect water resources. The StormTech system is designed primarily to be used under parking lots, thus maximizing land usage for private (commercial) and public applications. StormTech chambers can also be used in conjunction with Green Infrastructure, thus enhancing the performance and extending the service life of these practices.

- Nominal Chamber Specifications** (not to scale)
- Size (L x W x H)**  
90" x 77" x 45"  
2286 mm x 1956 mm x 1143 mm
- Chamber Storage**  
109.9 ft³ (3.11 m³)
- Min. Installed Storage\***  
175.0 ft³ (4.96 m³)
- Weight**  
134 lbs (60.8 kg)
- Shipping**  
15 chambers/pallet  
7 end caps/pallet  
7 pallets/truck
- Nominal End Cap Specifications** (not to scale)
- Size (L x W x H)**  
26.5" x 71" x 45.1"  
673 mm x 1803 mm x 1145 mm
- End Cap Storage**  
14.9 ft³ (0.42 m³)
- Min. Installed Storage\***  
45.1 ft³ (1.28 m³)
- Weight**  
49 lbs (22.2 kg)
- \*Assumes a minimum of 12" (300 mm) of stone above, 9" (230 mm) of stone below, 6" (150 mm) of stone perimeter, 6" (150 mm) of stone between chambers/ end caps and 40% stone porosity.

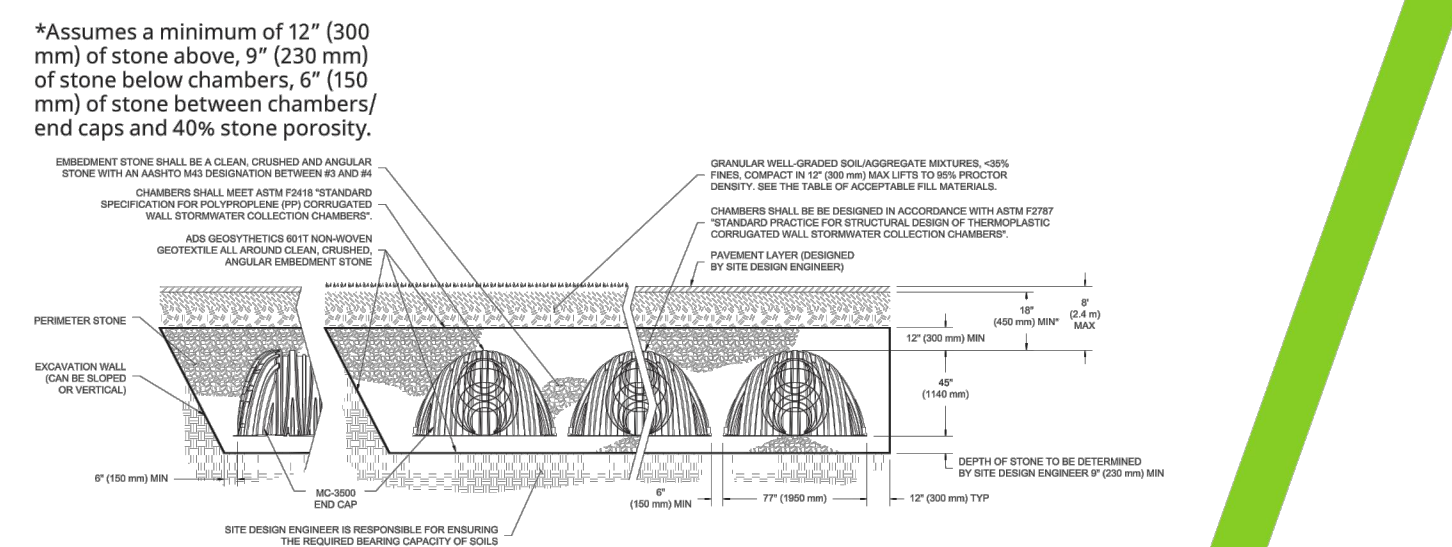
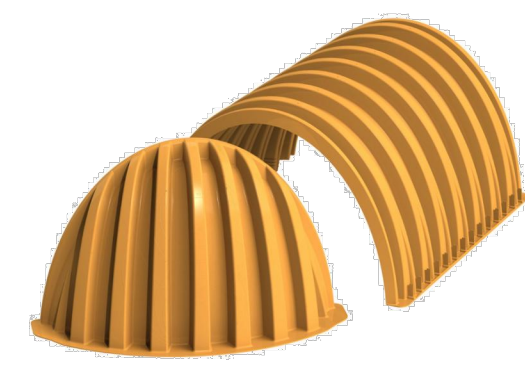

**ADS StormTech**

ADS StormTech and CodeBooks of Rain are available on the ADS website, [www.ads-pipe.com](http://www.ads-pipe.com)

The ADS logo and the CodeBooks of Rain are registered trademarks of ADS Advanced Drainage Systems, Inc.

StormTech® is a registered trademark of StormTech, Inc.

© 2022 ADS Advanced Drainage Systems, Inc. 481-0000-1022-13

## StormTech MC-3500 Specifications

**Storage Volume Per Chamber**

Bare Chamber Storage ft³ (m³)	Chamber and Stone Foundation Depth in. (mm)			
	9 in (230 mm)	12 in (300 mm)	15 in (375 mm)	18 in (450 mm)
Chamber	109.9 (3.11)	175.0 (4.96)	179.9 (5.09)	184.9 (5.24)
End Cap	14.9 (0.42)	45.1 (1.28)	46.6 (1.32)	48.3 (1.37)

Note: Assumes 6" (150 mm) row spacing, 40% stone porosity, 12" (300 mm) stone above and includes the bare chamber/end cap volume.

**Amount of Stone Per Chamber**

English Tons (yds³)	Stone Foundation Depth			
	9 in	12 in	15 in	18 in
Chamber	8.5 (6.0)	9.1 (6.5)	9.7 (6.9)	10.4 (7.4)
End Cap	3.9 (2.8)	4.1 (2.9)	4.3 (3.1)	4.5 (3.2)

**Metric Kilograms (m³)**

Chamber	Stone Foundation Depth			
	230 mm	300 mm	375 mm	450 mm
Chamber	7711 (4.6)	8255 (5.0)	8800 (5.3)	9435 (5.7)
End Cap	3538 (2.1)	3719 (2.2)	3901 (2.4)	4082 (2.5)

Note: Assumes 12" (300 mm) of stone above and 6" (150 mm) row spacing and 6" (150 mm) of perimeter stone in front of end caps.

**Volume Excavation Per Chamber yd³ (m³)**

Chamber	Stone Foundation Depth			
	9 in (230 mm)	12 in (300 mm)	15 in (375 mm)	18 in (450 mm)
Chamber	11.9 (9.1)	12.4 (9.5)	12.8 (9.6)	13.3 (10.2)
End Cap	4.0 (3.1)	4.1 (3.3)	4.3 (3.3)	4.4 (3.4)

Note: Assumes 6" (150 mm) of separation between chamber rows and 24" (600 mm) of cover. The volume of excavation will vary as depth of cover increases.

ADS StormTech products, manufactured in accordance with ASTM F2418 or ASTM F2922, comply with all requirements in the Build America, Buy America (BABA) Act.

Working on a project? Visit us at [ads-pipe.com/stormtech](http://ads-pipe.com/stormtech) and utilize the Design Tool

**ADS StormTech**

ads-pipe.com  
800-821-6710

**PREPARED FOR:**  
CRP/LOVETT CHINO INDUSTRIAL OWNER, L.L.C.  
610 NEWPORT CENTER DRIVE, SUITE 340  
NEWPORT BEACH, CA 92660  
PHONE: (949) 402-2760

**PREPARED BY:**  
**Tai Thienes Engineering, Inc.**  
CIVIL ENGINEERING • LAND SURVEYING  
14140 FIRESTONE BOULEVARD  
LA BREA, CALIFORNIA 90639  
PH: (714) 521-4811 FAX: (714) 521-4733

**CITY OF CHINO**  
PUBLIC WORKS DEPARTMENT

**PWOMP SITE PLAN**  
YORBA AVENUE INDUSTRIAL DEVELOPMENT  
13610 YORBA AVENUE

Designed by \_\_\_\_\_ Date \_\_\_\_\_  
Checked by \_\_\_\_\_  
Designed by \_\_\_\_\_ Date \_\_\_\_\_  
Checked by \_\_\_\_\_ Date \_\_\_\_\_

Approved by \_\_\_\_\_ Date \_\_\_\_\_  
Public Works Director R.C.E.

Sheet **2** of **2** Sheets

4163 / 2 OF 2 SHEETS

Last Update: 4/23/24  
D:\4160-4199\4163\4163PWOMPTEMP.dwg

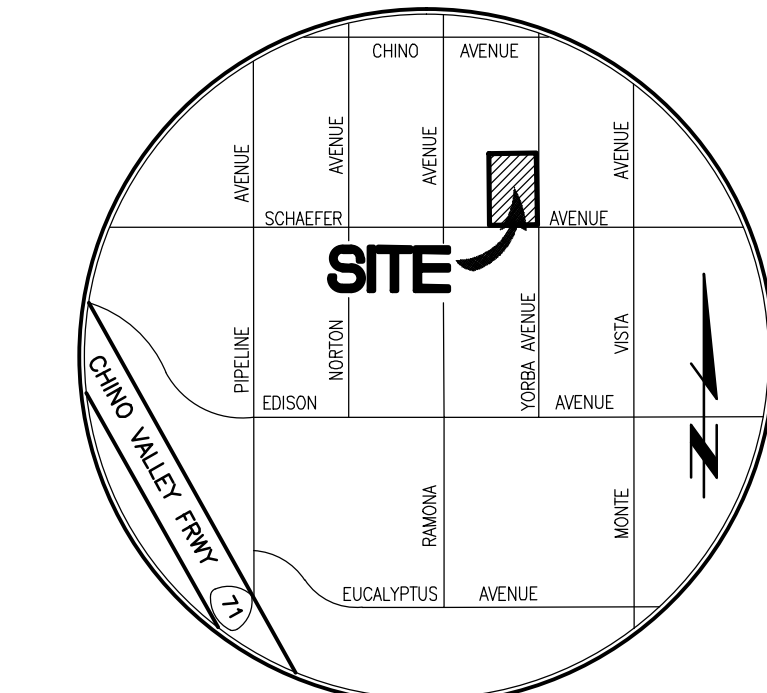

VICINITY MAP  
N.T.S.

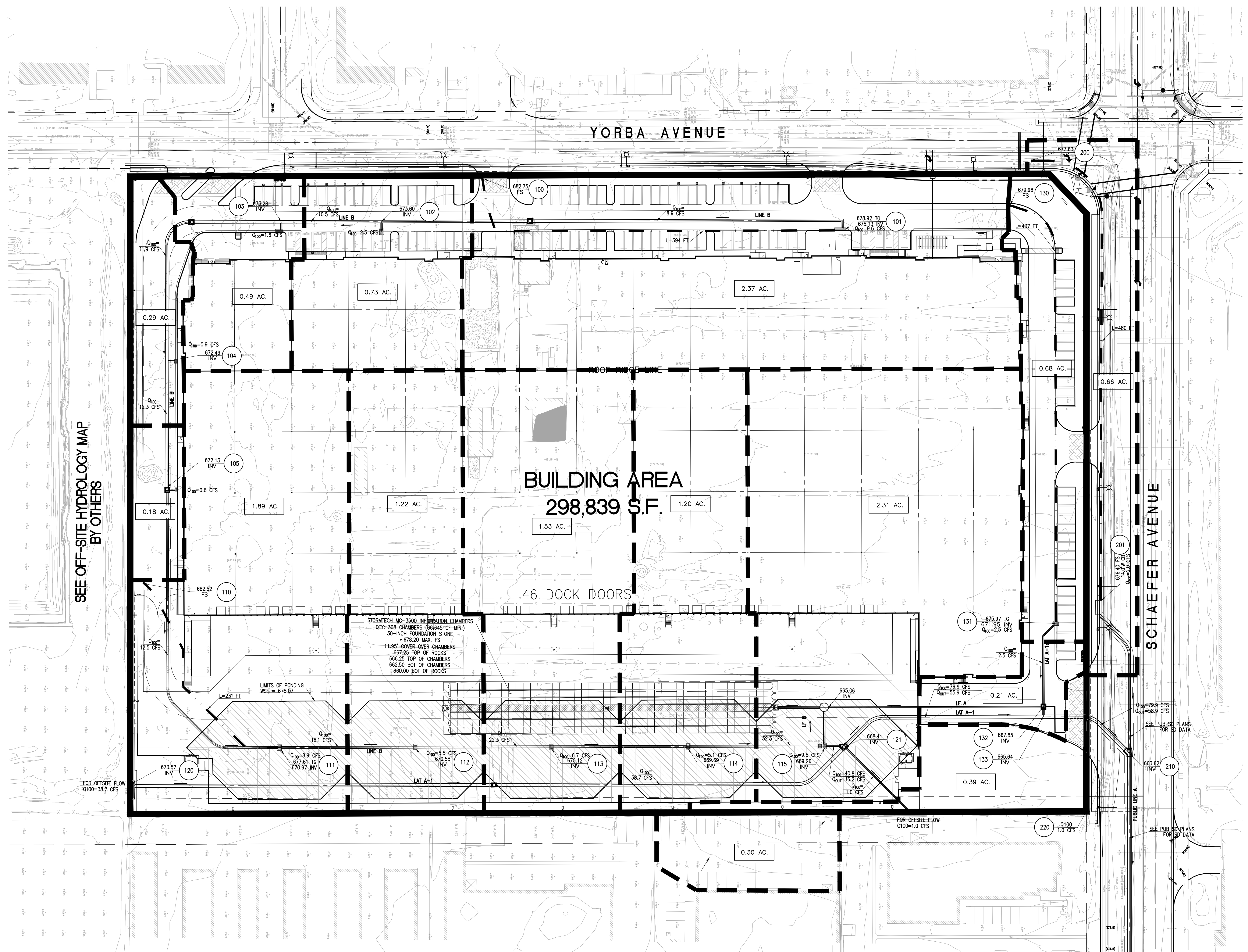

SEE OFF-SITE HYDROLOGY MAP  
BY OTHERS

SUBAREA DATA SUMMARY

NODES	AREA (ACRES)	SOIL TYPE	Tc (MINUTES)	Q100 (CFS)
100-101	2.37	B	8.39	8.9
102	0.73	B	10.05	2.5
103	0.49	B	10.39	1.6
104	0.29	B	11.21	0.9
105	0.18	B	11.66	0.6
110-111	1.89	B	5.79	8.9
112	1.22	B	6.22	5.5
113	1.53	B	6.61	6.7
114	1.20	B	6.98	5.1
115	2.31	B	7.34	9.5
120-121(O)	8.66	B	9.75	39.7
130-133	0.93	B	9.08	3.4
200-201	0.66	B	9.05	1.9
220	0.34	B	10.11	1.0

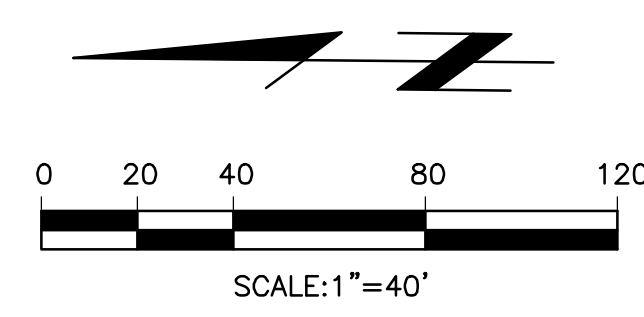
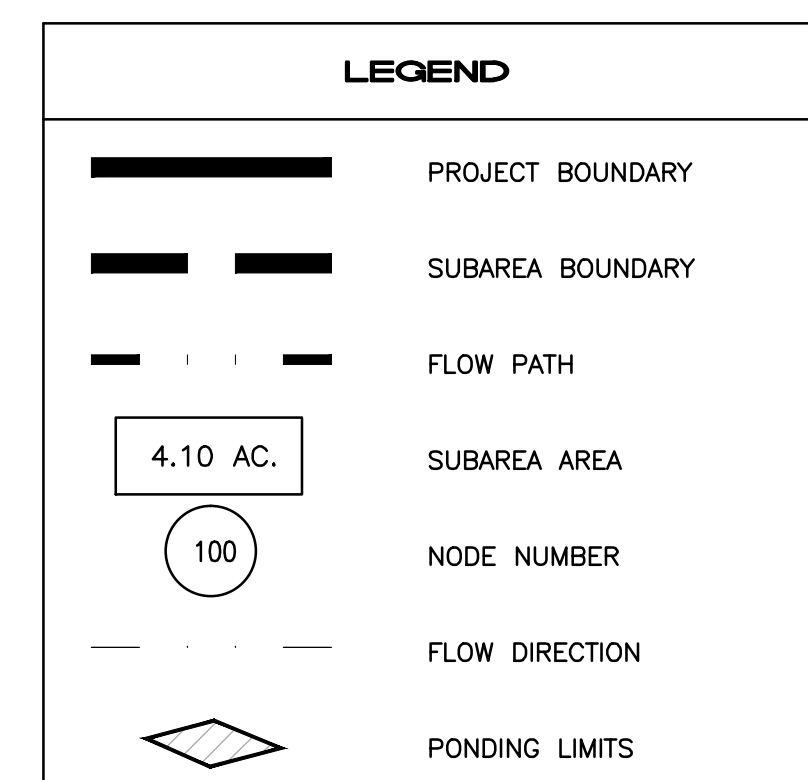

Last Update: 4/23/24  
0:\1100-4199\4163\4163HYD.dwg

**CITY OF CHINO**  
PUBLIC WORKS DEPARTMENT  
**PROPOSED HYDROLOGY MAP**  
YORBA AVENUE INDUSTRIAL DEVELOPMENT  
13610 YORBA AVENUE

PREPARED FOR:  
**LOVETT INDUSTRIAL**  
610 NEWPORT CENTER DRIVE, SUITE 340  
NEWPORT BEACH, CA 92660  
PHONE: (949) 402-2760



Designed by _____	Approved by _____	Date _____
Checked by _____	Public Works Director _____	R.C.E. XXXXX
Designed by _____		
Checked by _____		
Date _____		
Sheet <b>1</b> of <b>1</b>		Sheets

4163 / 1 OF 1 SHEET

## 6.2 Electronic Data Submittal in Compact Disk (CD)

Minimum requirements include submittal of PDF exhibits in addition to hard copies. Format must not require specialized software to open. If the local jurisdiction requires specialized electronic document formats (consult the LIP), this section will describe the contents (e.g., layering, nomenclature, geo-referencing, etc.) of these documents so that they may be interpreted efficiently and accurately.

## 6.3 Post Construction

Attach all O&M Plans and Maintenance Agreements for BMP to the WQMP (Attachment D).

**Attachment D**  
**WQMP and Stormwater BMP Transfer, Access**  
**and Maintenance Agreement**

AND WHEN RECORDED MAIL TO

City Clerk  
City of Chino  
P.O. Box 667  
Chino, CA 91708

SPACE ABOVE THIS LINE FOR RECORDER'S USE

**WATER QUALITY MANAGEMENT PLAN AND STORMWATER BMP  
TRANSFER, ACCESS AND MAINTENANCE AGREEMENT**

**CITY OF CHINO, COUNTY OF SAN BERNARDINO, STATE OF CALIFORNIA**

This Agreement is made and entered into this \_\_\_\_ day of \_\_\_\_\_, 20\_\_\_\_, by and between the CITY OF CHINO, a municipal corporation, hereinafter referred to as CITY, and \_\_\_\_\_ hereinafter referred to as OWNER.

WHEREAS, the Owner is the legal property owner of the real property situated in the State of California, County of San Bernardino, located at \_\_\_\_\_ in the City of Chino, more commonly referred to as San Bernardino County Tax Assessor Parcel No. \_\_\_\_\_ described in Exhibit A and depicted in Exhibit B attached hereto and incorporated herein by this reference; and

WHEREAS, at the time of initial approval of the development project known as \_\_\_\_\_ within the Property described herein, the City required the project to employ Best Management Practices, hereinafter referred to as "BMPs, " to minimize pollutants in urban runoff; and

WHEREAS, the Owner has chosen to install and/or implement BMPs as described in the Water Quality Management Plan, on file with the City, hereinafter referred to as "WQMP," to minimize pollutants in urban runoff and to minimize other adverse impacts of urban runoff; and

WHEREAS, said WQMP has been certified by the Owner and reviewed and approved by the City; and

WHEREAS, said BMPs, with installation and/or implementation on private property and draining only private property, are part of a private facility with all maintenance or replacement therefore, the sole responsibility of the Owner in accordance with the terms of this Agreement;

WHEREAS, the Owner is aware that periodic and continuous maintenance, including, but not necessarily limited to, filter material replacement and sediment removal, is required to assure peak performance of all BMPs in the WQMP and that, furthermore, such maintenance activity will require compliance with all Local, State, or Federal laws and regulations, including those pertaining to confined space and waste disposal methods, in effect at the time such maintenance occurs;

NOW THEREFORE, it is mutually stipulated and agreed as follows:

1. The Owner hereby provides the City or the City's designee complete access, of any duration, to the BMPs and their immediate vicinity at any time, upon reasonable notice, or in the event of emergency, as determined by City's Director of Public Works with no advance notice, for the purpose of inspection, sampling, testing of the BMPs, and in case of emergency, to undertake all necessary repairs or other preventative measures at the owner's expense as provided in paragraph 3 below. The City shall make every effort at all times to minimize or avoid interference with the Owner's use of the Property.

2. The Owner shall use its best efforts diligently to maintain all BMPs in a manner assuring peak performance at all times. All reasonable precautions shall be exercised by the Owner and the Owner's representative or contractor in the removal and extraction of any material(s) from the BMPs and the ultimate disposal of the material(s) in a manner consistent with all relevant laws and regulations in effect at the time. As may be requested from time to time by the City, the Owner shall provide the City with documentation identifying the material(s) removed, the quantity, and disposal destination.

3. In the event the Owner, or its successors or assigns, fails to accomplish the necessary maintenance contemplated by this Agreement, within five (5) days of being given written notice by the City, the City is hereby authorized to cause any maintenance necessary to be done and charge the entire cost and expense to the Owner or the Owner's successors or assigns, including administrative costs, attorneys fees and interest thereon at the maximum rate authorized by the Civil Code from the date of the notice of expense until paid in full.

4. The City may require the Owner to post security in form and for a time period satisfactory to the City to guarantee the performance of the obligations stated herein. Should the Owner fail to perform the obligations under this Agreement, the City may, in the case of a cash bond, act for the Owner using the proceeds from it, or in the case of a surety bond, require the sureties to perform the obligations of this Agreement. As an additional remedy, the Director may withdraw any previous stormwater-related approval with respect to the property on which BMPs have been installed and/or implemented until such time as the Owner repays to the City its reasonable costs incurred in accordance with paragraph 3 above.

5. This Agreement shall be recorded in the Office of the Recorder of San Bernardino County, California, at the expense of the Owner and shall constitute notice to all successors and assigns of the title to said Property of the obligation herein set forth, and also a lien in such amount as will fully reimburse the City, including interest as herein above set forth, subject to foreclosure in event of default in payment.

6. In event of legal action occasioned by any default or action of the Owner, or its successors or assigns, then the Owner and its successors or assigns agree(s) to pay all costs incurred by the City in enforcing the terms of this Agreement, including reasonable attorney's fees and costs, and that the same shall become a part of the lien against said Property.

7. It is the intent of the parties hereto that burdens and benefits herein undertaken shall constitute covenants that run with said Property and constitute a lien against the Property.

8. The obligations herein undertaken shall be binding upon the heirs, successors, executors, administrators and assigns of the parties hereto. The term "Owner" shall include not only the present Owner, but also its heirs, successors, executors, administrators, and assigns. The Owner shall notify any successor to title of all or part of the Property about the existence of this Agreement. The Owner shall provide such notice prior to such successor obtaining an interest in all or part of the Property. The Owner shall provide a copy of such notice to the City at the same time such notice is provided to the successor.

9. Time is of the essence in the performance of this Agreement.

10. Any notice to a party required or called for in this Agreement shall be served in person, or by deposit in the U.S. Mail, first class postage prepaid, to the address set forth below. Notice(s) shall be deemed effective upon receipt, or seventy-two (72) hours after deposit in the U.S. Mail, whichever is earlier. A party may change a notice address only by providing written notice thereof to the other party.

IF TO CITY:

IF TO OWNER:

Hye Jin, P.E.

Director of Public Works

13220 Central Avenue

Chino, CA 91710

IN WITNESS THEREOF, the parties hereto have affixed their signatures as of the date first written above.

APPROVED AS TO FORM:

APPROVED AS TO CONTENT:

By: (Signature Not Required)  
City Attorney

By: \_\_\_\_\_  
Hye Jin, P.E.  
Director of Public Works  
City of Chino

City of Chino

Owner: \_\_\_\_\_  
(Company)

By: \_\_\_\_\_  
Dr. Linda Reich  
City Manager

By: \_\_\_\_\_  
(Signature and Date)

Name: \_\_\_\_\_  
(Please Print or Type Name)

ATTEST:

\_\_\_\_\_  
Natalie Gonzaga, City Clerk

Title: \_\_\_\_\_  
(Please Print or Type Title)

**NOTE: OWNER'S SIGNATURE MUST BE NOTARIZED FOR RECORDATION**

## 6.4 Other Supporting Documentation

- BMP Educational Materials (Attachment E)
- Infiltration Report (Attachment F)
- HCOC (Attachment G)

**Attachment E**  
**BMP Educational Materials**

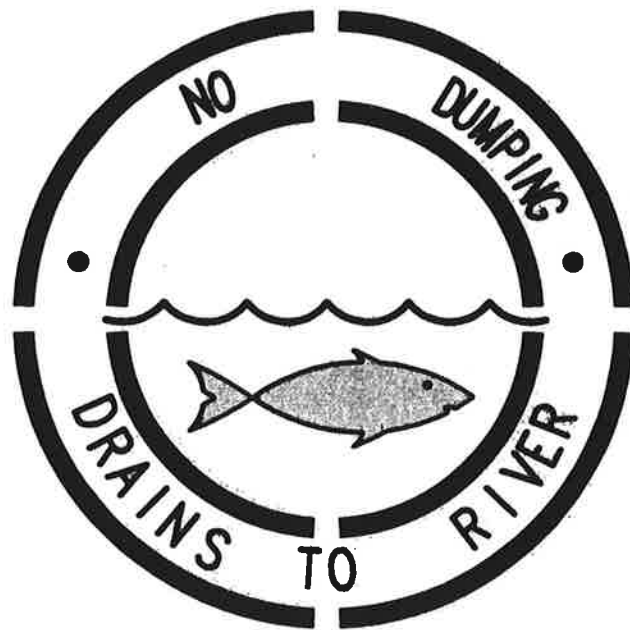

SAMPLE STENCIL TO BE USED NEAR  
GRATE AND CURB OPENING INLETS  
SYMBOL TO BE 24" IN DIAMETER



**Thienes Engineering**

CIVIL ENGINEERING • LAND SURVEYING  
14349 FIRESTONE BOULEVARD  
LA MIRADA, CALIFORNIA 90638  
PH(714)521-4811 FAX(714)521-4173

**SAMPLE CATCH BASIN STENCIL  
PER BMP SD-13**

## CDS<sup>®</sup> Inspection and Maintenance Guide

---



## Maintenance

The CDS system should be inspected at regular intervals and maintained when necessary to ensure optimum performance. The rate at which the system collects pollutants will depend more heavily on site activities than the size of the unit. For example, unstable soils or heavy winter sanding will cause the grit chamber to fill more quickly but regular sweeping of paved surfaces will slow accumulation.

## Inspection

Inspection is the key to effective maintenance and is easily performed. Pollutant transport and deposition may vary from year to year and regular inspections will help ensure that the system is cleaned out at the appropriate time. At a minimum, inspections should be performed twice per year (e.g. spring and fall) however more frequent inspections may be necessary in climates where winter sanding operations may lead to rapid accumulations, or in equipment washdown areas. Installations should also be inspected more frequently where excessive amounts of trash are expected.

The visual inspection should ascertain that the system components are in working order and that there are no blockages or obstructions in the inlet and separation screen. The inspection should also quantify the accumulation of hydrocarbons, trash, and sediment in the system. Measuring pollutant accumulation can be done with a calibrated dipstick, tape measure or other measuring instrument. If absorbent material is used for enhanced removal of hydrocarbons, the level of discoloration of the sorbent material should also be identified during inspection. It is useful and often required as part of an operating permit to keep a record of each inspection. A simple form for doing so is provided.

Access to the CDS unit is typically achieved through two manhole access covers. One opening allows for inspection and cleanout of the separation chamber (cylinder and screen) and isolated sump. The other allows for inspection and cleanout of sediment captured and retained outside the screen. For deep units, a single manhole access point would allow both sump cleanout and access outside the screen.

The CDS system should be cleaned when the level of sediment has reached 75% of capacity in the isolated sump or when an appreciable level of hydrocarbons and trash has accumulated. If absorbent material is used, it should be replaced when significant discoloration has occurred. Performance will not be impacted until 100% of the sump capacity is exceeded however it is recommended that the system be cleaned prior to that for easier removal of sediment. The level of sediment is easily determined by measuring from finished grade down to the top of the sediment pile. To avoid underestimating the level of sediment in the chamber, the measuring device must be lowered to the top of the sediment pile carefully. Particles at the top of the pile typically offer less resistance to the end of the rod than consolidated particles toward the bottom of the pile. Once this measurement is recorded, it should be compared to the as-built drawing for the unit to determine whether the height of the sediment pile off the bottom of the sump floor exceeds 75% of the total height of isolated sump.

## Cleaning

Cleaning of a CDS system should be done during dry weather conditions when no flow is entering the system. The use of a vacuum truck is generally the most effective and convenient method of removing pollutants from the system. Simply remove the manhole covers and insert the vacuum hose into the sump. The system should be completely drained down and the sump fully evacuated of sediment. The area outside the screen should also be cleaned out if pollutant build-up exists in this area.

In installations where the risk of petroleum spills is small, liquid contaminants may not accumulate as quickly as sediment. However, the system should be cleaned out immediately in the event of an oil or gasoline spill should be cleaned out immediately. Motor oil and other hydrocarbons that accumulate on a more routine basis should be removed when an appreciable layer has been captured. To remove these pollutants, it may be preferable to use absorbent pads since they are usually less expensive to dispose than the oil/water emulsion that may be created by vacuuming the oily layer. Trash and debris can be netted out to separate it from the other pollutants. The screen should be power washed to ensure it is free of trash and debris.

Manhole covers should be securely seated following cleaning activities to prevent leakage of runoff into the system from above and also to ensure that proper safety precautions have been followed. Confined space entry procedures need to be followed if physical access is required. Disposal of all material removed from the CDS system should be done in accordance with local regulations. In many jurisdictions, disposal of the sediments may be handled in the same manner as the disposal of sediments removed from catch basins or deep sump manholes.



CDS Model	Diameter		Distance from Water Surface to Top of Sediment Pile		Sediment Storage Capacity	
	ft	m	ft	m	yd3	m3
CDS2015-4	4	1.2	3.0	0.9	0.5	0.4
CDS2015	5	1.5	3.0	0.9	1.3	1.0
CDS2020	5	1.5	3.5	1.1	1.3	1.0
CDS2025	5	1.5	4.0	1.2	1.3	1.0
CDS3020	6	1.8	4.0	1.2	2.1	1.6
CDS3030	6	1.8	4.6	1.4	2.1	1.6
CDS3035	6	1.8	5.0	1.5	2.1	1.6
CDS4030	8	2.4	4.6	1.4	5.6	4.3
CDS4040	8	2.4	5.7	1.7	5.6	4.3
CDS4045	8	2.4	6.2	1.9	5.6	4.3

Table 1: CDS Maintenance Indicators and Sediment Storage Capacities



#### Support

- Drawings and specifications are available at [www.contechstormwater.com](http://www.contechstormwater.com).
- Site-specific design support is available from our engineers.

©2014 Contech Engineered Solutions LLC

Contech Engineered Solutions LLC provides site solutions for the civil engineering industry. Contech's portfolio includes bridges, drainage, sanitary sewer, stormwater, earth stabilization and wastewater treatment products. For information, visit [www.ContechES.com](http://www.ContechES.com) or call 800.338.1122

NOTHING IN THIS CATALOG SHOULD BE CONSTRUED AS AN EXPRESSED WARRANTY OR AN IMPLIED WARRANTY OF MERCHANTABILITY OR FITNESS FOR ANY PARTICULAR PURPOSE. SEE THE CONTECH STANDARD CONDITION OF SALES (VIEWABLE AT [WWW.CONTECHES.COM/COS](http://WWW.CONTECHES.COM/COS)) FOR MORE INFORMATION.

The product(s) described may be protected by one or more of the following US patents: 5,322,629; 5,624,576; 5,707,527; 5,759,415; 5,788,848; 5,985,157; 6,027,639; 6,350,374; 6,406,218; 6,641,720; 6,511,595; 6,649,048; 6,991,114; 6,998,038; 7,186,058; 7,296,692; 7,297,266; 7,517,450 related foreign patents or other patents pending.



# StormTech<sup>®</sup> MC-3500 Chamber

Designed to meet the most stringent industry performance standards for superior structural integrity while providing designers with a cost-effective method to save valuable land and protect water resources. The StormTech system is designed primarily to be used under parking lots, thus maximizing land usage for private (commercial) and public applications. StormTech chambers can also be used in conjunction with Green Infrastructure, thus enhancing the performance and extending the service life of these practices.

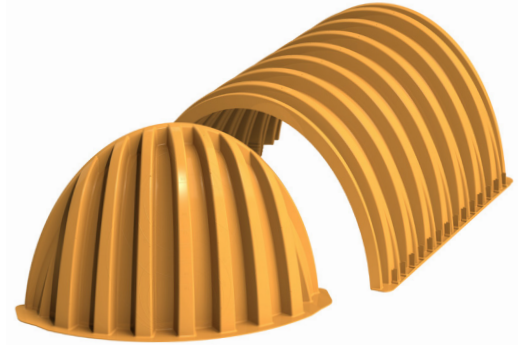

## Nominal Chamber Specifications (not to scale)

**Size (L x W x H)**  
 90" x 77" x 45"  
 2286 mm x 1956 mm x 1143 mm

**Chamber Storage**  
 109.9 ft<sup>3</sup> (3.11 m<sup>3</sup>)

**Min. Installed Storage\***  
 175.0 ft<sup>3</sup> (4.96 m<sup>3</sup>)

**Weight**  
 134 lbs (60.8 kg)

**Shipping**  
 15 chambers/pallet  
 7 end caps/pallet  
 7 pallets/truck

\*Assumes a minimum of 12" (300 mm) of stone above, 9" (230 mm) of stone below chambers, 6" (150 mm) of stone between chambers/ end caps and 40% stone porosity.

## Nominal End Cap Specifications (not to scale)

**Size (L x W x H)**  
 26.5" x 71" x 45.1"  
 673 mm x 1803 mm x 1145 mm

**End Cap Storage**  
 14.9 ft<sup>3</sup> (0.42 m<sup>3</sup>)

**Min. Installed Storage\***  
 45.1 ft<sup>3</sup> (1.28 m<sup>3</sup>)

**Weight**  
 49 lbs (22.2 kg)

\*Assumes a minimum of 12" (300 mm) of stone above, 9" (230 mm) of stone below, 6" (150 mm) of stone perimeter, 6" (150 mm) of stone between chambers/ end caps and 40% stone porosity.

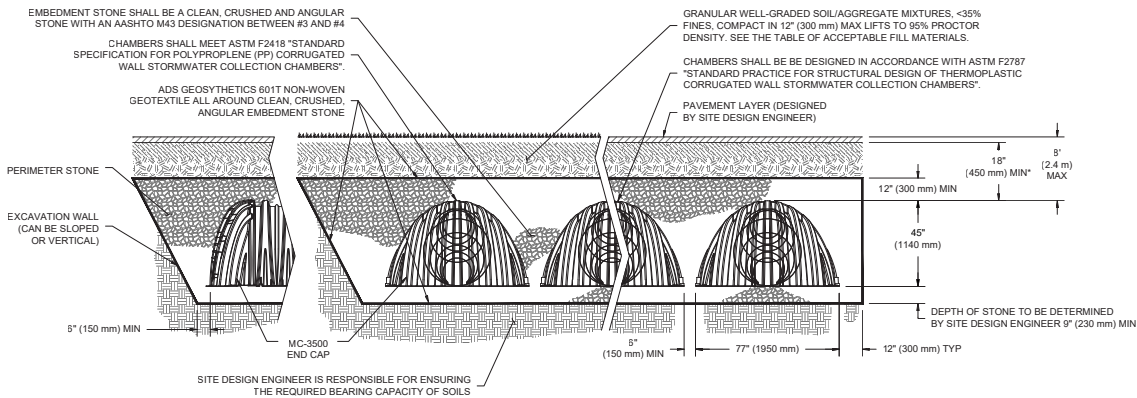
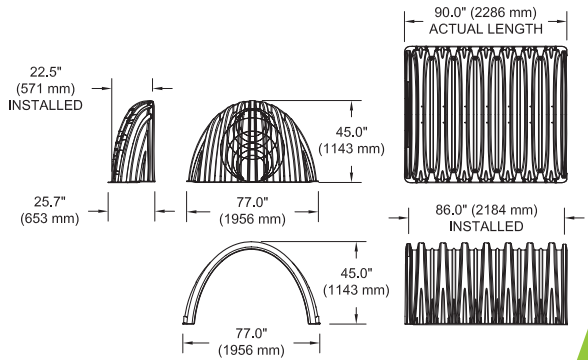

\*MINIMUM COVER TO BOTTOM OF FLEXIBLE PAVEMENT. FOR UNPAVED INSTALLATIONS WHERE RUTTING FROM VEHICLES MAY OCCUR, INCREASE COVER TO 24" (600 mm).

# StormTech MC-3500 Specifications

## Storage Volume Per Chamber

	Bare Chamber Storage ft <sup>3</sup> (m <sup>3</sup> )	Chamber and Stone Foundation Depth in. (mm)			
		9 in (230 mm)	12 in (300 mm)	15 in (375 mm)	18 in (450 mm)
Chamber	109.9 (3.11)	175.0 (4.96)	179.9 (5.09)	184.9 (5.24)	189.9 (5.38)
End Cap	14.9 (0.42)	45.1 (1.28)	46.6 (1.32)	48.3 (1.37)	49.9 (1.41)

**Note:** Assumes 6" (150 mm) row spacing, 40% stone porosity, 12" (300 mm) stone above and includes the bare chamber/end cap volume.

## Amount of Stone Per Chamber

English Tons (yds <sup>3</sup> )	Stone Foundation Depth			
	9 in	12 in	15 in	18 in
Chamber	8.5 (6.0)	9.1 (6.5)	9.7 (6.9)	10.4 (7.4)
End Cap	3.9 (2.8)	4.1 (2.9)	4.3 (3.1)	4.5 (3.2)
Metric Kilograms (m <sup>3</sup> )	230 mm	300 mm	375 mm	450 mm
Chamber	7711 (4.6)	8255 (5.0)	8800 (5.3)	9435 (5.7)
End Cap	3538 (2.1)	3719 (2.2)	3901 (2.4)	4082 (2.5)

**Note:** Assumes 12" (300 mm) of stone above and 6" (150 mm) row spacing and 6" (150 mm) of perimeter stone in front of end caps.

## Volume Excavation Per Chamber yd<sup>3</sup> (m<sup>3</sup>)

	Stone Foundation Depth			
	9 in (230 mm)	12 in (300 mm)	15 in (375mm)	18 in (450 mm)
Chamber	11.9 (9.1)	12.4 (9.5)	12.8 (9.8)	13.3 (10.2)
End Cap	4.0 (3.1)	4.1 (3.3)	4.3 (3.3)	4.4 (3.4)

**Note:** Assumes 6" (150 mm) of separation between chamber rows and 24" (600 mm) of cover. The volume of excavation will vary as depth of cover increases.

ADS StormTech products, manufactured in accordance with ASTM F2418 or ASTM F2922, comply with all requirements in the Build America, Buy America (BABA) Act.

**Working on a project?**

Visit us at [adspipe.com/stormtech](https://adspipe.com/stormtech) and utilize the Design Tool



# Isolator<sup>®</sup> Row O&M Manual



## THE ISOLATOR<sup>®</sup> ROW

### INTRODUCTION

An important component of any Stormwater Pollution Prevention Plan is inspection and maintenance. The StormTech Isolator Row is a technique to inexpensively enhance Total Suspended Solids (TSS) removal and provide easy access for inspection and maintenance.

### THE ISOLATOR ROW

The Isolator Row is a row of StormTech chambers, either SC-160LP, SC-310, SC-310-3, SC-740, DC-780, MC-3500 or MC-4500 models, that is surrounded with filter fabric and connected to a closely located manhole for easy access. The fabric-wrapped chambers provide for settling and filtration of sediment as storm water rises in the Isolator Row and ultimately passes through the filter fabric. The open bottom chambers and perforated sidewalls (SC-310, SC-310-3 and SC-740 models) allow storm water to flow both vertically and horizontally out of the chambers. Sediments are captured in the Isolator Row protecting the storage areas of the adjacent stone and chambers from sediment accumulation.

Two different fabrics are used for the Isolator Row. A woven geotextile fabric is placed between the stone and the Isolator Row chambers. The tough geotextile provides a media for storm water filtration and provides a durable surface for maintenance operations. It is also designed to prevent scour of the underlying stone and remain intact during high pressure jetting. A non-woven fabric is placed over the chambers to provide a filter media for flows passing through the perforations in the sidewall of the chamber. The non-woven fabric is not required over the SC-160LP, DC-780, MC-3500 or MC-4500 models as these chambers do not have perforated side walls.

The Isolator Row is typically designed to capture the “first flush” and offers the versatility to be sized on a volume basis or flow rate basis. An upstream manhole not only provides access to the Isolator Row but typically includes a high flow weir such that storm water flowrates or volumes that exceed the capacity of the Isolator Row overtop the overflow weir and discharge through a manifold to the other chambers.

The Isolator Row may also be part of a treatment train. By treating storm water prior to entry into the chamber system, the service life can be extended and pollutants such as hydrocarbons can be captured. Pre-treatment best management practices can be as simple as deep sump catch basins, oil-water separators or can be innovative storm water treatment devices. The design of the treatment train and selection of pretreatment devices by the design engineer is often driven by regulatory requirements. Whether pretreatment is used or not, the Isolator Row is recommended by StormTech as an effective means to minimize maintenance requirements and maintenance costs.

*Note: See the StormTech Design Manual for detailed information on designing inlets for a StormTech system, including the Isolator Row.*



Looking down the Isolator Row from the manhole opening, woven geotextile is shown between the chamber and stone base.



StormTech Isolator Row with Overflow Spillway (not to scale)

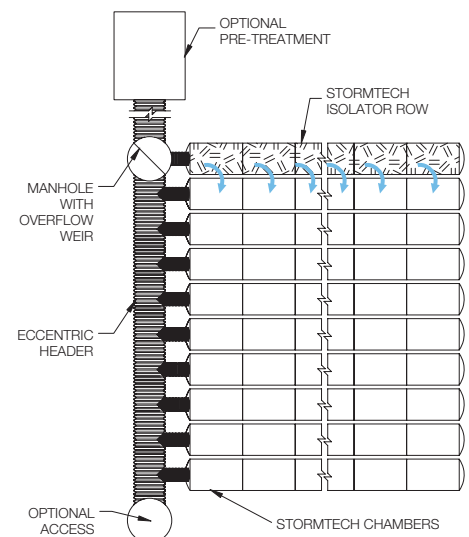

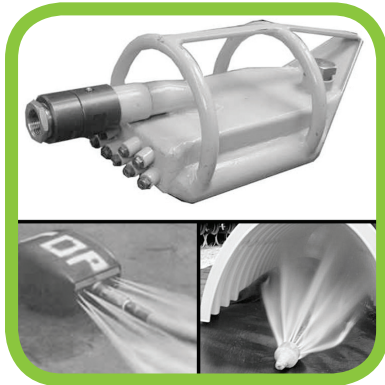

## ISOLATOR ROW INSPECTION/MAINTENANCE

### INSPECTION

The frequency of inspection and maintenance varies by location. A routine inspection schedule needs to be established for each individual location based upon site specific variables. The type of land use (i.e. industrial, commercial, residential), anticipated pollutant load, percent imperviousness, climate, etc. all play a critical role in determining the actual frequency of inspection and maintenance practices.

At a minimum, StormTech recommends annual inspections. Initially, the Isolator Row should be inspected every 6 months for the first year of operation. For subsequent years, the inspection should be adjusted based upon previous observation of sediment deposition.

The Isolator Row incorporates a combination of standard manhole(s) and strategically located inspection ports (as needed). The inspection ports allow for easy access to the system from the surface, eliminating the need to perform a confined space entry for inspection purposes.

If upon visual inspection it is found that sediment has accumulated, a stadia rod should be inserted to determine the depth of sediment. When the average depth of sediment exceeds 3 inches throughout the length of the Isolator Row, clean-out should be performed.

### MAINTENANCE

The Isolator Row was designed to reduce the cost of periodic maintenance. By “isolating” sediments to just one row, costs are dramatically reduced by eliminating the need to clean out each row of the entire storage bed. If inspection indicates the potential need for maintenance, access is provided via a manhole(s) located on the end(s) of the row for cleanout. If entry into the manhole is required, please follow local and OSHA rules for a confined space entries.

Maintenance is accomplished with the JetVac process. The JetVac process utilizes a high pressure water nozzle to propel itself down the Isolator Row while scouring and suspending sediments. As the nozzle is retrieved, the captured pollutants are flushed back into the manhole for vacuuming. Most sewer and pipe maintenance companies have vacuum/JetVac combination vehicles. Selection of an appropriate JetVac nozzle will improve maintenance efficiency. Fixed nozzles designed for culverts or large diameter pipe cleaning are preferable. Rear facing jets with an effective spread of at least 45” are best. Most JetVac reels have 400 feet of hose allowing maintenance of an Isolator Row up to 50 chambers long. **The JetVac process shall only be performed on StormTech Isolator Rows that have AASHTO class 1 woven geotextile (as specified by StormTech) over their angular base stone.**

### StormTech Isolator Row (not to scale)

*Note: Non-woven fabric is only required over the inlet pipe connection into the end cap for SC-160LP, DC-780, MC-3500 and MC-4500 chamber models and is not required over the entire Isolator Row.*

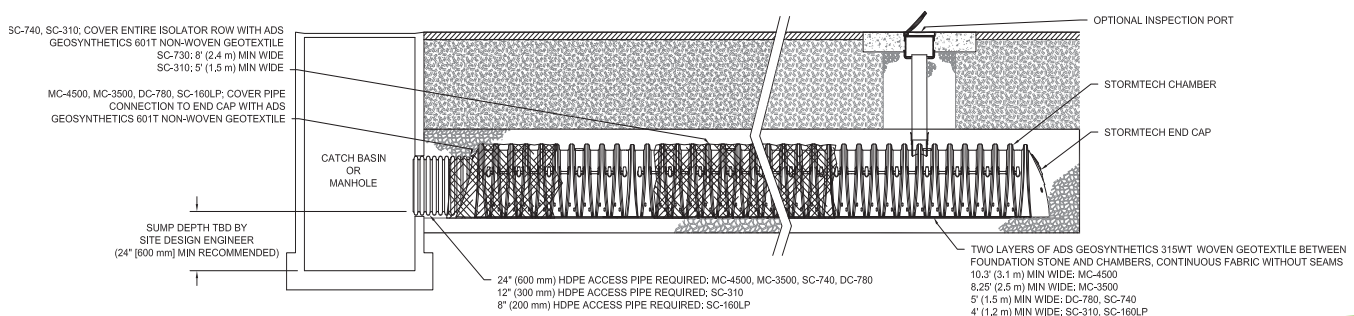

# ISOLATOR ROW STEP BY STEP MAINTENANCE PROCEDURES

## STEP 1

Inspect Isolator Row for sediment.

- A) Inspection ports (if present)
  - i. Remove lid from floor box frame
  - ii. Remove cap from inspection riser
  - iii. Using a flashlight and stadia rod, measure depth of sediment and record results on maintenance log.
  - iv. If sediment is at or above 3 inch depth, proceed to Step 2. If not, proceed to Step 3.
- B) All Isolator Rows
  - i. Remove cover from manhole at upstream end of Isolator Row
  - ii. Using a flashlight, inspect down Isolator Row through outlet pipe
    - 1. Mirrors on poles or cameras may be used to avoid a confined space entry
    - 2. Follow OSHA regulations for confined space entry if entering manhole
  - iii. If sediment is at or above the lower row of sidewall holes (approximately 3 inches), proceed to Step 2. If not, proceed to Step 3.

## STEP 2

Clean out Isolator Row using the JetVac process.

- A) A fixed floor cleaning nozzle with rear facing nozzle spread of 45 inches or more is preferable
- B) Apply multiple passes of JetVac until backflush water is clean
- C) Vacuum manhole sump as required

## STEP 3

Replace all caps, lids and covers, record observations and actions.

## STEP 4

Inspect & clean catch basins and manholes upstream of the StormTech system.

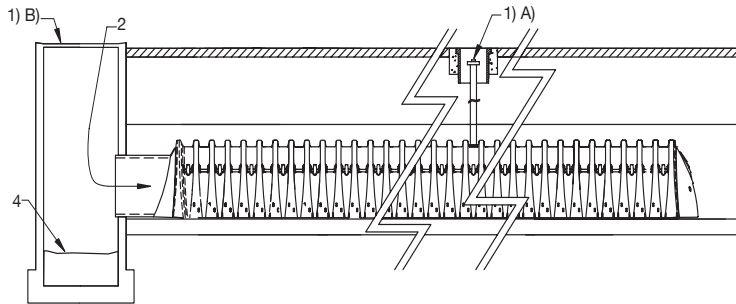

## SAMPLE MAINTENANCE LOG

Date	Stadia Rod Readings		Sediment Depth (1)-(2)	Observations/Actions	Inspector
	Fixed point to chamber bottom (1)	Fixed point to top of sediment (2)			
3/15/11	6.3 ft	none		New installation. Fixed point is CI frame at grade	DJM
9/24/11		6.2	0.1 ft	Some grit felt	SM
6/20/13		5.8	0.5 ft	Mucky feel, debris visible in manhole and in Isolator Row, maintenance due	NV
7/7/13	6.3 ft		0	System jetted and vacuumed	DJM



Art Credit: Margie Winter

## Description

Non-stormwater discharges are those flows that do not consist entirely of stormwater. Some non-stormwater discharges do not include pollutants and may be discharged to the storm drain. These include uncontaminated groundwater and natural springs. There are also some non-stormwater discharges that typically do not contain pollutants and may be discharged to the storm drain with conditions. These include car washing, air conditioner condensate, etc. However there are certain non-stormwater discharges that pose environmental concern. These discharges may originate from illegal dumping or from internal floor drains, appliances, industrial processes, sinks, and toilets that are connected to the nearby storm drainage system. These discharges (which may include: process waste waters, cooling waters, wash waters, and sanitary wastewater) can carry substances such as paint, oil, fuel and other automotive fluids, chemicals and other pollutants into storm drains. They can generally be detected through a combination of detection and elimination. The ultimate goal is to effectively eliminate non-stormwater discharges to the stormwater drainage system through implementation of measures to detect, correct, and enforce against illicit connections and illegal discharges of pollutants on streets and into the storm drain system and creeks.

## Approach

Initially the industry must make an assessment of non-stormwater discharges to determine which types must be eliminated or addressed through BMPs. The focus of the following approach is in the elimination of non-stormwater discharges.

## Objectives

- Cover
- Contain
- Educate
- Reduce/Minimize
- Product Substitution

## Targeted Constituents

Sediment	
Nutrients	✓
Trash	
Metals	✓
Bacteria	✓
Oil and Grease	✓
Organics	✓



## ***Pollution Prevention***

- Ensure that used oil, used antifreeze, and hazardous chemical recycling programs are being implemented. Encourage litter control.

## ***Suggested Protocols***

### *Recommended Complaint Investigation Equipment*

- Field Screening Analysis
  - pH paper or meter
  - Commercial stormwater pollutant screening kit that can detect for reactive phosphorus, nitrate nitrogen, ammonium nitrogen, specific conductance, and turbidity
  - Sample jars
  - Sample collection pole
  - A tool to remove access hole covers
- Laboratory Analysis
  - Sample cooler
  - Ice
  - Sample jars and labels
  - Chain of custody forms
- Documentation
  - Camera
  - Notebook
  - Pens
  - Notice of Violation forms
  - Educational materials

### *General*

- Develop clear protocols and lines of communication for effectively prohibiting non-stormwater discharges, especially those that are not classified as hazardous. These are often not responded to as effectively as they need to be.
- Stencil or demarcate storm drains, where applicable, to prevent illegal disposal of pollutants. Storm drain inlets should have messages such as “Dump No Waste Drains to Stream” stenciled or demarcated next to them to warn against ignorant or intentional dumping of pollutants into the storm drainage system.

- See SC44 Stormwater Drainage System Maintenance for additional information.

### *Illicit Connections*

- Locate discharges from the industrial storm drainage system to the municipal storm drain system through review of “as-built” piping schematics.
- Isolate problem areas and plug illicit discharge points.
- Locate and evaluate all discharges to the industrial storm drain system.

### *Visual Inspection and Inventory*

- Inventory and inspect each discharge point during dry weather.
- Keep in mind that drainage from a storm event can continue for a day or two following the end of a storm and groundwater may infiltrate the underground stormwater collection system. Also, non-stormwater discharges are often intermittent and may require periodic inspections.

### *Review Infield Piping*

- A review of the “as-built” piping schematic is a way to determine if there are any connections to the stormwater collection system.
- Inspect the path of floor drains in older buildings.

### *Smoke Testing*

- Smoke testing of wastewater and stormwater collection systems is used to detect connections between the two systems.
- During dry weather the stormwater collection system is filled with smoke and then traced to sources. The appearance of smoke at the base of a toilet indicates that there may be a connection between the sanitary and the stormwater system.

### *Dye Testing*

- A dye test can be performed by simply releasing a dye into either your sanitary or process wastewater system and examining the discharge points from the stormwater collection system for discoloration.

### *TV Inspection of Drainage System*

- TV Cameras can be employed to visually identify illicit connections to the industrial storm drainage system.

### *Illegal Dumping*

- Regularly inspect and clean up hot spots and other storm drainage areas where illegal dumping and disposal occurs.
- On paved surfaces, clean up spills with as little water as possible. Use a rag for small spills, a damp mop for general cleanup, and absorbent material for larger spills. If the spilled material is hazardous, then the used cleanup materials are also hazardous and must be sent to a certified laundry (rags) or disposed of as hazardous waste.

- Never hose down or bury dry material spills. Sweep up the material and dispose of properly.
- Use adsorbent materials on small spills rather than hosing down the spill. Remove the adsorbent materials promptly and dispose of properly.
- For larger spills, a private spill cleanup company or Hazmat team may be necessary.

Once a site has been cleaned:

- Post “No Dumping” signs with a phone number for reporting dumping and disposal.
- Landscaping and beautification efforts of hot spots may also discourage future dumping, as well as provide open space and increase property values.
- Lighting or barriers may also be needed to discourage future dumping.
- See fact sheet SC11 Spill Prevention, Control, and Cleanup.

#### *Inspection*

- Regularly inspect and clean up hot spots and other storm drainage areas where illegal dumping and disposal occurs.
- Conduct field investigations of the industrial storm drain system for potential sources of non-stormwater discharges.
- Pro-actively conduct investigations of high priority areas. Based on historical data, prioritize specific geographic areas and/or incident type for pro-active investigations.

#### *Reporting*

- A database is useful for defining and tracking the magnitude and location of the problem.
- Report prohibited non-stormwater discharges observed during the course of normal daily activities so they can be investigated, contained, and cleaned up or eliminated.
- Document that non-stormwater discharges have been eliminated by recording tests performed, methods used, dates of testing, and any on-site drainage points observed.
- Document and report annually the results of the program.
- Maintain documentation of illicit connection and illegal dumping incidents, including significant conditionally exempt discharges that are not properly managed.

#### *Training*

- Training of technical staff in identifying and documenting illegal dumping incidents is required.
- Consider posting the quick reference table near storm drains to reinforce training.
- Train employees to identify non-stormwater discharges and report discharges to the appropriate departments.

- Educate employees about spill prevention and cleanup.
- Well-trained employees can reduce human errors that lead to accidental releases or spills. The employee should have the tools and knowledge to immediately begin cleaning up a spill should one occur. Employees should be familiar with the Spill Prevention Control and Countermeasure Plan.
- Determine and implement appropriate outreach efforts to reduce non-permissible non-stormwater discharges.
- Conduct spill response drills annually (if no events occurred to evaluate your plan) in cooperation with other industries.
- When a responsible party is identified, educate the party on the impacts of his or her actions.

### ***Spill Response and Prevention***

- See SC11 Spill Prevention Control and Cleanup.

### ***Other Considerations***

- Many facilities do not have accurate, up-to-date schematic drawings.

### **Requirements**

#### ***Costs (including capital and operation & maintenance)***

- The primary cost is for staff time and depends on how aggressively a program is implemented.
- Cost for containment and disposal is borne by the discharger.
- Illicit connections can be difficult to locate especially if there is groundwater infiltration.
- Indoor floor drains may require re-plumbing if cross-connections to storm drains are detected.

#### ***Maintenance (including administrative and staffing)***

- Illegal dumping and illicit connection violations requires technical staff to detect and investigate them.

### **Supplemental Information**

#### ***Further Detail of the BMP***

##### ***Illegal Dumping***

- Substances illegally dumped on streets and into the storm drain systems and creeks include paints, used oil and other automotive fluids, construction debris, chemicals, fresh concrete, leaves, grass clippings, and pet wastes. All of these wastes cause stormwater and receiving water quality problems as well as clog the storm drain system itself.
- Establish a system for tracking incidents. The system should be designed to identify the following:
  - Illegal dumping hot spots

- Types and quantities (in some cases) of wastes
- Patterns in time of occurrence (time of day/night, month, or year)
- Mode of dumping (abandoned containers, “midnight dumping” from moving vehicles, direct dumping of materials, accidents/spills)
- Responsible parties

One of the keys to success of reducing or eliminating illegal dumping is increasing the number of people at the facility who are aware of the problem and who have the tools to at least identify the incident, if not correct it. Therefore, train field staff to recognize and report the incidents.

What constitutes a “non-stormwater” discharge?

- Non-stormwater discharges to the stormwater collection system may include any water used directly in the manufacturing process (process wastewater), air conditioning condensate and coolant, non-contact cooling water, cooling equipment condensate, outdoor secondary containment water, vehicle and equipment wash water, sink and drinking fountain wastewater, sanitary wastes, or other wastewaters.

#### *Permit Requirements*

- Facilities subject to stormwater permit requirements must include a certification that the stormwater collection system has been tested or evaluated for the presence of non-stormwater discharges. The State’s General Industrial Stormwater Permit requires that non-stormwater discharges be eliminated prior to implementation of the facility’s SWPPP.

#### *Performance Evaluation*

- Review annually internal investigation results; assess whether goals were met and what changes or improvements are necessary.
- Obtain feedback from personnel assigned to respond to, or inspect for, illicit connections and illegal dumping incidents.

### **References and Resources**

California’s Nonpoint Source Program Plan <http://www.swrcb.ca.gov/nps/index.html>

Clark County Storm Water Pollution Control Manual  
<http://www.co.clark.wa.us/pubworks/bmpman.pdf>

King County Storm Water Pollution Control Manual <http://dnr.metrokc.gov/wlr/dss/spcm.htm>

Santa Clara Valley Urban Runoff Pollution Prevention Program <http://www.scvurppp.org>

The Storm Water Managers Resource Center <http://www.stormwatercenter.net/>

# Spill Prevention, Control & Cleanup SC-11



Photo Credit: Geoff Brosseau

## Objectives

- Cover
- Contain
- Educate
- Reduce/Minimize
- Product Substitution

## Description

Many activities that occur at an industrial or commercial site have the potential to cause accidental or illegal spills. Preparation for accidental or illegal spills, with proper training and reporting systems implemented, can minimize the discharge of pollutants to the environment.

Spills and leaks are one of the largest contributors of stormwater pollutants. Spill prevention and control plans are applicable to any site at which hazardous materials are stored or used. An effective plan should have spill prevention and response procedures that identify potential spill areas, specify material handling procedures, describe spill response procedures, and provide spill clean-up equipment. The plan should take steps to identify and characterize potential spills, eliminate and reduce spill potential, respond to spills when they occur in an effort to prevent pollutants from entering the stormwater drainage system, and train personnel to prevent and control future spills.

## Approach

### *Pollution Prevention*

- Develop procedures to prevent/mitigate spills to storm drain systems. Develop and standardize reporting procedures, containment, storage, and disposal activities, documentation, and follow-up procedures.
- Develop a Spill Prevention Control and Countermeasure (SPCC) Plan. The plan should include:

## Targeted Constituents

Sediment	
Nutrients	
Trash	
Metals	✓
Bacteria	
Oil and Grease	✓
Organics	✓



# **SC-11 Spill Prevention, Control & Cleanup**

---

- Description of the facility, owner and address, activities and chemicals present
- Facility map
- Notification and evacuation procedures
- Cleanup instructions
- Identification of responsible departments
- Identify key spill response personnel
- Recycle, reclaim, or reuse materials whenever possible. This will reduce the amount of process materials that are brought into the facility.

## ***Suggested Protocols (including equipment needs)***

### ***Spill Prevention***

- Develop procedures to prevent/mitigate spills to storm drain systems. Develop and standardize reporting procedures, containment, storage, and disposal activities, documentation, and follow-up procedures.
- If consistent illegal dumping is observed at the facility:
  - Post “No Dumping” signs with a phone number for reporting illegal dumping and disposal. Signs should also indicate fines and penalties applicable for illegal dumping.
  - Landscaping and beautification efforts may also discourage illegal dumping.
  - Bright lighting and/or entrance barriers may also be needed to discourage illegal dumping.
- Store and contain liquid materials in such a manner that if the tank is ruptured, the contents will not discharge, flow, or be washed into the storm drainage system, surface waters, or groundwater.
- If the liquid is oil, gas, or other material that separates from and floats on water, install a spill control device (such as a tee section) in the catch basins that collects runoff from the storage tank area.
- Routine maintenance:
  - Place drip pans or absorbent materials beneath all mounted taps, and at all potential drip and spill locations during filling and unloading of tanks. Any collected liquids or soiled absorbent materials must be reused/recycled or properly disposed.
  - Store and maintain appropriate spill cleanup materials in a location known to all near the tank storage area; and ensure that employees are familiar with the site’s spill control plan and/or proper spill cleanup procedures.
  - Sweep and clean the storage area monthly if it is paved, *do not hose down the area to a storm drain.*

# Spill Prevention, Control & Cleanup SC-11

---

- Check tanks (and any containment sumps) daily for leaks and spills. Replace tanks that are leaking, corroded, or otherwise deteriorating with tanks in good condition. Collect all spilled liquids and properly dispose of them.
- Label all containers according to their contents (e.g., solvent, gasoline).
- Label hazardous substances regarding the potential hazard (corrosive, radioactive, flammable, explosive, poisonous).
- Prominently display required labels on transported hazardous and toxic materials (per US DOT regulations).
- Identify key spill response personnel.

## *Spill Control and Cleanup Activities*

- Follow the Spill Prevention Control and Countermeasure Plan.
- Clean up leaks and spills immediately.
- Place a stockpile of spill cleanup materials where it will be readily accessible (e.g., near storage and maintenance areas).
- On paved surfaces, clean up spills with as little water as possible. Use a rag for small spills, a damp mop for general cleanup, and absorbent material for larger spills. If the spilled material is hazardous, then the used cleanup materials are also hazardous and must be sent to a certified laundry (rags) or disposed of as hazardous waste. Physical methods for the cleanup of dry chemicals include the use of brooms, shovels, sweepers, or plows.
- Never hose down or bury dry material spills. Sweep up the material and dispose of properly.
- Chemical cleanups of material can be achieved with the use of adsorbents, gels, and foams. Use adsorbent materials on small spills rather than hosing down the spill. Remove the adsorbent materials promptly and dispose of properly.
- For larger spills, a private spill cleanup company or Hazmat team may be necessary.

## *Reporting*

- Report spills that pose an immediate threat to human health or the environment to the Regional Water Quality Control Board.
- Federal regulations require that any oil spill into a water body or onto an adjoining shoreline be reported to the National Response Center (NRC) at 800-424-8802 (24 hour).
- Report spills to local agencies, such as the fire department; they can assist in cleanup.
- Establish a system for tracking incidents. The system should be designed to identify the following:
  - Types and quantities (in some cases) of wastes
  - Patterns in time of occurrence (time of day/night, month, or year)

# **SC-11 Spill Prevention, Control & Cleanup**

---

- Mode of dumping (abandoned containers, “midnight dumping” from moving vehicles, direct dumping of materials, accidents/spills)
- Responsible parties

## ***Training***

- Educate employees about spill prevention and cleanup.
- Well-trained employees can reduce human errors that lead to accidental releases or spills:
  - The employee should have the tools and knowledge to immediately begin cleaning up a spill should one occur.
  - Employees should be familiar with the Spill Prevention Control and Countermeasure Plan.
- Employees should be educated about aboveground storage tank requirements. Employees responsible for aboveground storage tanks and liquid transfers should be thoroughly familiar with the Spill Prevention Control and Countermeasure Plan and the plan should be readily available.
- Train employees to recognize and report illegal dumping incidents.

## ***Other Considerations (Limitations and Regulations)***

- State regulations exist for facilities with a storage capacity of 10,000 gallons or more of petroleum to prepare a Spill Prevention Control and Countermeasure (SPCC) Plan (Health & Safety Code Chapter 6.67).
- State regulations also exist for storage of hazardous materials (Health & Safety Code Chapter 6.95), including the preparation of area and business plans for emergency response to the releases or threatened releases.
- Consider requiring smaller secondary containment areas (less than 200 sq. ft.) to be connected to the sanitary sewer, prohibiting any hard connections to the storm drain.

## **Requirements**

### ***Costs (including capital and operation & maintenance)***

- Will vary depending on the size of the facility and the necessary controls.
- Prevention of leaks and spills is inexpensive. Treatment and/or disposal of contaminated soil or water can be quite expensive.

### ***Maintenance (including administrative and staffing)***

- This BMP has no major administrative or staffing requirements. However, extra time is needed to properly handle and dispose of spills, which results in increased labor costs.

# Spill Prevention, Control & Cleanup SC-11

---

## Supplemental Information

### *Further Detail of the BMP*

#### *Reporting*

Record keeping and internal reporting represent good operating practices because they can increase the efficiency of the facility and the effectiveness of BMPs. A good record keeping system helps the facility minimize incident recurrence, correctly respond with appropriate cleanup activities, and comply with legal requirements. A record keeping and reporting system should be set up for documenting spills, leaks, and other discharges, including discharges of hazardous substances in reportable quantities. Incident records describe the quality and quantity of non-stormwater discharges to the storm sewer. These records should contain the following information:

- Date and time of the incident
- Weather conditions
- Duration of the spill/leak/discharge
- Cause of the spill/leak/discharge
- Response procedures implemented
- Persons notified
- Environmental problems associated with the spill/leak/discharge

Separate record keeping systems should be established to document housekeeping and preventive maintenance inspections, and training activities. All housekeeping and preventive maintenance inspections should be documented. Inspection documentation should contain the following information:

- The date and time the inspection was performed
- Name of the inspector
- Items inspected
- Problems noted
- Corrective action required
- Date corrective action was taken

Other means to document and record inspection results are field notes, timed and dated photographs, videotapes, and drawings and maps.

#### *Aboveground Tank Leak and Spill Control*

Accidental releases of materials from aboveground liquid storage tanks present the potential for contaminating stormwater with many different pollutants. Materials spilled, leaked, or lost from

# **SC-11 Spill Prevention, Control & Cleanup**

---

tanks may accumulate in soils or on impervious surfaces and be carried away by stormwater runoff.

The most common causes of unintentional releases are:

- Installation problems
- Failure of piping systems (pipes, pumps, flanges, couplings, hoses, and valves)
- External corrosion and structural failure
- Spills and overfills due to operator error
- Leaks during pumping of liquids or gases from truck or rail car to a storage tank or vice versa

Storage of reactive, ignitable, or flammable liquids should comply with the Uniform Fire Code and the National Electric Code. Practices listed below should be employed to enhance the code requirements:

- Tanks should be placed in a designated area.
- Tanks located in areas where firearms are discharged should be encapsulated in concrete or the equivalent.
- Designated areas should be impervious and paved with Portland cement concrete, free of cracks and gaps, in order to contain leaks and spills.
- Liquid materials should be stored in UL approved double walled tanks or surrounded by a curb or dike to provide the volume to contain 10 percent of the volume of all of the containers or 110 percent of the volume of the largest container, whichever is greater. The area inside the curb should slope to a drain.
- For used oil or dangerous waste, a dead-end sump should be installed in the drain.
- All other liquids should be drained to the sanitary sewer if available. The drain must have a positive control such as a lock, valve, or plug to prevent release of contaminated liquids.
- Accumulated stormwater in petroleum storage areas should be passed through an oil/water separator.

Maintenance is critical to preventing leaks and spills. Conduct routine inspections and:

- Check for external corrosion and structural failure.
- Check for spills and overfills due to operator error.
- Check for failure of piping system (pipes, pumps, flanger, coupling, hoses, and valves).
- Check for leaks or spills during pumping of liquids or gases from truck or rail car to a storage facility or vice versa.

# Spill Prevention, Control & Cleanup SC-11

---

- Visually inspect new tank or container installation for loose fittings, poor welding, and improper or poorly fitted gaskets.
- Inspect tank foundations, connections, coatings, and tank walls and piping system. Look for corrosion, leaks, cracks, scratches, and other physical damage that may weaken the tank or container system.
- Frequently relocate accumulated stormwater during the wet season.
- Periodically conduct integrity testing by a qualified professional.

## *Vehicle Leak and Spill Control*

Major spills on roadways and other public areas are generally handled by highly trained Hazmat teams from local fire departments or environmental health departments. The measures listed below pertain to leaks and smaller spills at vehicle maintenance shops.

In addition to implementing the spill prevention, control, and clean up practices above, use the following measures related to specific activities:

## *Vehicle and Equipment Maintenance*

- Perform all vehicle fluid removal or changing inside or under cover to prevent the run-on of stormwater and the runoff of spills.
- Regularly inspect vehicles and equipment for leaks, and repair immediately.
- Check incoming vehicles and equipment (including delivery trucks, and employee and subcontractor vehicles) for leaking oil and fluids. Do not allow leaking vehicles or equipment onsite.
- Always use secondary containment, such as a drain pan or drop cloth, to catch spills or leaks when removing or changing fluids.
- Immediately drain all fluids from wrecked vehicles.
- Store wrecked vehicles or damaged equipment under cover.
- Place drip pans or absorbent materials under heavy equipment when not in use.
- Use adsorbent materials on small spills rather than hosing down the spill.
- Remove the adsorbent materials promptly and dispose of properly.
- Promptly transfer used fluids to the proper waste or recycling drums. Don't leave full drip pans or other open containers lying around.
- Oil filters disposed of in trashcans or dumpsters can leak oil and contaminate stormwater. Place the oil filter in a funnel over a waste oil recycling drum to drain excess oil before disposal. Oil filters can also be recycled. Ask your oil supplier or recycler about recycling oil filters.

# **SC-11 Spill Prevention, Control & Cleanup**

---

- Store cracked batteries in a non-leaking secondary container. Do this with all cracked batteries, even if you think all the acid has drained out. If you drop a battery, treat it as if it is cracked. Put it into the containment area until you are sure it is not leaking.

## *Vehicle and Equipment Fueling*

- Design the fueling area to prevent the run-on of stormwater and the runoff of spills:
  - Cover fueling area if possible.
  - Use a perimeter drain or slope pavement inward with drainage to a sump.
  - Pave fueling area with concrete rather than asphalt.
- If dead-end sump is not used to collect spills, install an oil/water separator.
- Install vapor recovery nozzles to help control drips as well as air pollution.
- Discourage “topping-off” of fuel tanks.
- Use secondary containment when transferring fuel from the tank truck to the fuel tank.
- Use adsorbent materials on small spills and general cleaning rather than hosing down the area. Remove the adsorbent materials promptly.
- Carry out all Federal and State requirements regarding underground storage tanks, or install above ground tanks.
- Do not use mobile fueling of mobile industrial equipment around the facility; rather, transport the equipment to designated fueling areas.
- Keep your Spill Prevention Control and Countermeasure (SPCC) Plan up-to-date.
- Train employees in proper fueling and cleanup procedures.

## *Industrial Spill Prevention Response*

For the purposes of developing a spill prevention and response program to meet the stormwater regulations, facility managers should use information provided in this fact sheet and the spill prevention/response portions of the fact sheets in this handbook, for specific activities. The program should:

- Integrate with existing emergency response/hazardous materials programs (e.g., Fire Department)
- Develop procedures to prevent/mitigate spills to storm drain systems
- Identify responsible departments
- Develop and standardize reporting procedures, containment, storage, and disposal activities, documentation, and follow-up procedures
- Address spills at municipal facilities, as well as public areas

# **Spill Prevention, Control & Cleanup SC-11**

---

- Provide training concerning spill prevention, response and cleanup to all appropriate personnel

## **References and Resources**

California's Nonpoint Source Program Plan <http://www.swrcb.ca.gov/nps/index.html>

Clark County Storm Water Pollution Control Manual  
<http://www.co.clark.wa.us/pubworks/bmpman.pdf>

King County Storm Water Pollution Control Manual <http://dnr.metrokc.gov/wlr/dss/spcm.htm>

Santa Clara Valley Urban Runoff Pollution Prevention Program <http://www.scvurppp.org>

The Stormwater Managers Resource Center <http://www.stormwatercenter.net/>



Photo Credit: Geoff Brosseau

## Description

The loading/unloading of materials usually takes place outside on docks or terminals; therefore, materials spilled, leaked, or lost during loading/unloading may collect in the soil or on other surfaces and have the potential to be carried away by stormwater runoff or when the area is cleaned. Additionally, rainfall may wash pollutants from machinery used to unload or move materials. Implementation of the following protocols will prevent or reduce the discharge of pollutants to stormwater from outdoor loading/unloading of materials.

## Approach

Reduce potential for pollutant discharge through source control pollution prevention and BMP implementation. Successful implementation depends on effective training of employees on applicable BMPs and general pollution prevention strategies and objectives.

## Pollution Prevention

- Keep accurate maintenance logs to evaluate materials removed and improvements made.
- Park tank trucks or delivery vehicles in designated areas so that spills or leaks can be contained.
- Limit exposure of material to rainfall whenever possible.
- Prevent stormwater run-on.
- Check equipment regularly for leaks.

## Objectives

- Cover
- Contain
- Educate
- Reduce/Minimize
- Product Substitution

## Targeted Constituents

Sediment	✓
Nutrients	✓
Trash	
Metals	✓
Bacteria	
Oil and Grease	✓
Organics	✓



***Suggested Protocols******Loading and Unloading – General Guidelines***

- Develop an operations plan that describes procedures for loading and/or unloading.
- Conduct loading and unloading in dry weather if possible.
- Cover designated loading/unloading areas to reduce exposure of materials to rain.
- Consider placing a seal or door skirt between delivery vehicles and building to prevent exposure to rain.
- Design loading/unloading area to prevent stormwater run-on, which would include grading or berming the area, and position roof downspouts so they direct stormwater away from the loading/unloading areas.
- Have employees load and unload all materials and equipment in covered areas such as building overhangs at loading docks if feasible.
- Load/unload only at designated loading areas.
- Use drip pans underneath hose and pipe connections and other leak-prone spots during liquid transfer operations, and when making and breaking connections. Several drip pans should be stored in a covered location near the liquid transfer area so that they are always available, yet protected from precipitation when not in use. Drip pans can be made specifically for railroad tracks. Drip pans must be cleaned periodically, and drip collected materials must be disposed of properly.
- Pave loading areas with concrete instead of asphalt.
- Avoid placing storm drains in the area.
- Grade and/or berm the loading/unloading area to a drain that is connected to a deadend.

***Inspection***

- Check loading and unloading equipment regularly for leaks, including valves, pumps, flanges and connections.
- Look for dust or fumes during loading or unloading operations.

***Training***

- Train employees (e.g., fork lift operators) and contractors on proper spill containment and cleanup.
- Have employees trained in spill containment and cleanup present during loading/unloading.
- Train employees in proper handling techniques during liquid transfers to avoid spills.
- Make sure forklift operators are properly trained on loading and unloading procedures.

## ***Spill Response and Prevention***

- Keep your Spill Prevention Control and Countermeasure (SPCC) Plan up-to-date.
- Contain leaks during transfer.
- Store and maintain appropriate spill cleanup materials in a location that is readily accessible and known to all and ensure that employees are familiar with the site's spill control plan and proper spill cleanup procedures.
- Have an emergency spill cleanup plan readily available.
- Use drip pans or comparable devices when transferring oils, solvents, and paints.

## ***Other Considerations (Limitations and Regulations)***

- Space and time limitations may preclude all transfers from being performed indoors or under cover.
- It may not be possible to conduct transfers only during dry weather.

## **Requirements**

### ***Costs***

Costs should be low except when covering a large loading/unloading area.

### ***Maintenance***

- Conduct regular inspections and make repairs as necessary. The frequency of repairs will depend on the age of the facility.
- Check loading and unloading equipment regularly for leaks.
- Conduct regular broom dry-sweeping of area.

## **Supplemental Information**

### ***Further Detail of the BMP***

#### ***Special Circumstances for Indoor Loading/Unloading of Materials***

Loading or unloading of liquids should occur in the manufacturing building so that any spills that are not completely retained can be discharged to the sanitary sewer, treatment plant, or treated in a manner consistent with local sewer authorities and permit requirements.

- For loading and unloading tank trucks to above and below ground storage tanks, the following procedures should be used:
  - The area where the transfer takes place should be paved. If the liquid is reactive with the asphalt, Portland cement should be used to pave the area.
  - The transfer area should be designed to prevent run-on of stormwater from adjacent areas. Sloping the pad and using a curb, like a speed bump, around the uphill side of the transfer area should reduce run-on.

- The transfer area should be designed to prevent runoff of spilled liquids from the area. Sloping the area to a drain should prevent runoff. The drain should be connected to a dead-end sump or to the sanitary sewer. A positive control valve should be installed on the drain.
- For transfer from rail cars to storage tanks that must occur outside, use the following procedures:
  - Drip pans should be placed at locations where spillage may occur, such as hose connections, hose reels, and filler nozzles. Use drip pans when making and breaking connections.
  - Drip pan systems should be installed between the rails to collect spillage from tank cars.

**References and Resources**

California's Nonpoint Source Program Plan <http://www.swrcb.ca.gov/nps/index.html>

Clark County Storm Water Pollution Control Manual  
<http://www.co.clark.wa.us/pubworks/bmpman.pdf>

King County Storm Water Pollution Control Manual <http://dnr.metrokc.gov/wlr/dss/spcm.htm>

Santa Clara Valley Urban Runoff Pollution Prevention Program <http://www.scvurppp.org>

The Storm Water Managers Resource Center <http://www.stormwatercenter.net/>

## Description

Outside process equipment operations and maintenance can contaminate stormwater runoff. Activities, such as grinding, painting, coating, sanding, degreasing or parts cleaning, landfills and waste piles, solid waste treatment and disposal, are examples of process operations that can lead to contamination of stormwater runoff. Source controls for outdoor process equipment operations and maintenance include reducing the amount of waste created, enclosing or covering all or some of the equipment, installing secondary containment, and training employees.

## Approach

### *Pollution Prevention*

- Perform the activity during dry periods.
- Use non-toxic chemicals for maintenance and minimize or eliminate the use of solvents.

### *Suggested Protocols*

- Consider enclosing the activity in a building and connecting the floor drains to the sanitary sewer.
- Cover the work area with a permanent roof if possible.
- Minimize contact of stormwater with outside process equipment operations through berming and drainage routing (run-on prevention). If possible, connect process equipment area to public sewer or facility wastewater treatment system. Some municipalities require that secondary containment areas be connected to the sanitary sewer, prohibiting any hard connections to the storm drain.
- Dry clean the work area regularly.

### *Training*

- Train employees to perform the activity during dry periods only or substituting benign materials for more toxic ones.
- Train employee and contractors in proper techniques for spill containment and cleanup. Employees should have the tools and knowledge to immediately begin cleaning up a spill should one occur.

### *Spill Response and Prevention*

- Keep your Spill Prevention Control and Countermeasure (SPCC) Plan up-to-date.

## Objectives

- Cover
- Contain
- Educate
- Reduce/Minimize

## Targeted Constituents

Sediment	✓
Nutrients	
Trash	
Metals	✓
Bacteria	
Oil and Grease	✓
Organics	✓



# SC-32 Outdoor Equipment Operations

---

- Have employees trained in emergency spill cleanup procedures present when dangerous waste, liquid chemicals, or other wastes are delivered.
- Place a stockpile of spill cleanup materials where it will be readily accessible.
- Prevent operator errors by using engineering safe guards and thus reducing accidental releases of pollutant.
- Inspect storage areas regularly for leaks or spills. Also check for structural failure, spills and overfills due to operator error, and/or failure of piping system.

## ***Other Considerations***

- Providing cover may be expensive.
- Space limitations may preclude enclosing some equipment.
- Storage sheds often must meet building and fire code requirements.

## **Requirements**

### ***Costs***

Costs vary depending on the complexity of the operation and the amount of control necessary for stormwater pollution control.

### ***Maintenance***

- Conduct routine preventive maintenance, including checking process equipment for leaks.
- Clean the storm drain system regularly.

## **Supplemental Information**

### ***Further Detail of the BMP***

#### ***Hydraulic/Treatment Modifications***

If stormwater becomes polluted, it should be captured and treated. If you do not have your own process wastewater treatment system, consider discharging to the public sewer system. Use of the public sewer might be allowed under the following conditions:

- If the activity area is very small (less than a few hundred square feet), the local sewer authority may be willing to allow the area to remain uncovered with the drain connected to the public sewer.
- It may be possible under unusual circumstances to connect a much larger area to the public sewer, as long as the rate of stormwater discharges does not exceed the capacity of the wastewater treatment plant. The stormwater could be stored during the storm and then transferred to the public sewer when the normal flow is low, such as at night.

Industries that generate large volumes of process wastewater typically have their own treatment system and corresponding permit. These industries have the discretion to use their wastewater treatment system to treat stormwater within the constraints of their permit requirements for process treatment. It may also be possible for the industry to discharge the stormwater directly to an effluent outfall without treatment as long as the total loading of the discharged process

water and stormwater does not exceed the loading had a stormwater treatment device been used. This could be achieved by reducing the loading from the process wastewater treatment system. Check with your Regional Water Quality Control Board or local sewerage agency, as this option would be subject to permit constraints and potentially regular monitoring.

## References and Resources

California's Nonpoint Source Program Plan <http://www.swrcb.ca.gov/nps/index.html>

Clark County Storm Water Pollution Control Manual  
<http://www.co.clark.wa.us/pubworks/bmpman.pdf>

King County Storm Water Pollution Control Manual <http://dnr.metrokc.gov/wlr/dss/spcm.htm>

Santa Clara Valley Urban Runoff Pollution Prevention Program <http://www.scvurppp.org>

The Stormwater Managers Resource Center <http://www.stormwatercenter.net>



Photo Credit: Geoff Brosseau

## Description

Improper storage and handling of solid wastes can allow toxic compounds, oils and greases, heavy metals, nutrients, suspended solids, and other pollutants to enter stormwater runoff. The discharge of pollutants to stormwater from waste handling and disposal can be prevented and reduced by tracking waste generation, storage, and disposal; reducing waste generation and disposal through source reduction, reuse, and recycling; and preventing run-on and runoff.

## Approach

### *Pollution Prevention*

- Accomplish reduction in the amount of waste generated using the following source controls:
  - Production planning and sequencing
  - Process or equipment modification
  - Raw material substitution or elimination
  - Loss prevention and housekeeping
  - Waste segregation and separation
  - Close loop recycling
- Establish a material tracking system to increase awareness about material usage. This may reduce spills and minimize contamination, thus reducing the amount of waste produced.
- Recycle materials whenever possible.

## Objectives

- Cover
- Contain
- Educate
- Reduce/Minimize
- Product Substitution

## Targeted Constituents

Sediment	
Nutrients	
Trash	
Metals	✓
Bacteria	✓
Oil and Grease	✓
Organics	✓



***Suggested Protocols******General***

- Cover storage containers with leak proof lids or some other means. If waste is not in containers, cover all waste piles (plastic tarps are acceptable coverage) and prevent stormwater run-on and runoff with a berm. The waste containers or piles must be covered except when in use.
- Use drip pans or absorbent materials whenever grease containers are emptied by vacuum trucks or other means. Grease cannot be left on the ground. Collected grease must be properly disposed of as garbage.
- Check storage containers weekly for leaks and to ensure that lids are on tightly. Replace any that are leaking, corroded, or otherwise deteriorating.
- Sweep and clean the storage area regularly. If it is paved, do not hose down the area to a storm drain.
- Dispose of rinse and wash water from cleaning waste containers into a sanitary sewer if allowed by the local sewer authority. Do not discharge wash water to the street or storm drain.
- Transfer waste from damaged containers into safe containers.
- Take special care when loading or unloading wastes to minimize losses. Loading systems can be used to minimize spills and fugitive emission losses such as dust or mist. Vacuum transfer systems can minimize waste loss.

***Controlling Litter***

- Post “No Littering” signs and enforce anti-litter laws.
- Provide a sufficient number of litter receptacles for the facility.
- Clean out and cover litter receptacles frequently to prevent spillage.

***Waste Collection***

- Keep waste collection areas clean.
- Inspect solid waste containers for structural damage regularly. Repair or replace damaged containers as necessary.
- Secure solid waste containers; containers must be closed tightly when not in use.
- Do not fill waste containers with washout water or any other liquid.
- Ensure that only appropriate solid wastes are added to the solid waste container. Certain wastes such as hazardous wastes, appliances, fluorescent lamps, pesticides, etc., may not be disposed of in solid waste containers (see chemical/ hazardous waste collection section below).

- Do not mix wastes; this can cause chemical reactions, make recycling impossible, and complicate disposal.

### *Good Housekeeping*

- Use all of the product before disposing of the container.
- Keep the waste management area clean at all times by sweeping and cleaning up spills immediately.
- Use dry methods when possible (e.g., sweeping, use of absorbents) when cleaning around restaurant/food handling dumpster areas. If water must be used after sweeping/using absorbents, collect water and discharge through grease interceptor to the sewer.

### *Chemical/Hazardous Wastes*

- Select designated hazardous waste collection areas on-site.
- Store hazardous materials and wastes in covered containers and protect them from vandalism.
- Place hazardous waste containers in secondary containment.
- Make sure that hazardous waste is collected, removed, and disposed of only at authorized disposal areas.
- Stencil or demarcate storm drains on the facility's property with prohibitive message regarding waste disposal.

### *Run-on/Runoff Prevention*

- Prevent stormwater run-on from entering the waste management area by enclosing the area or building a berm around the area.
- Prevent waste materials from directly contacting rain.
- Cover waste piles with temporary covering material such as reinforced tarpaulin, polyethylene, polyurethane, polypropylene or hypalon.
- Cover the area with a permanent roof if feasible.
- Cover dumpsters to prevent rain from washing waste out of holes or cracks in the bottom of the dumpster.
- Move the activity indoor after ensuring all safety concerns such as fire hazard and ventilation are addressed.

### *Inspection*

- Inspect and replace faulty pumps or hoses regularly to minimize the potential of releases and spills.
- Check waste management areas for leaking containers or spills.

- Repair leaking equipment including valves, lines, seals, or pumps promptly.

***Training***

- Train staff in pollution prevention measures and proper disposal methods.
- Train employees and contractors in proper spill containment and cleanup. The employee should have the tools and knowledge to immediately begin cleaning up a spill should one occur.
- Train employees and subcontractors in proper hazardous waste management.

***Spill Response and Prevention***

- Keep your Spill Prevention Control and Countermeasure (SPCC) Plan up-to-date.
- Have an emergency plan, equipment and trained personnel ready at all times to deal immediately with major spills
- Collect all spilled liquids and properly dispose of them.
- Store and maintain appropriate spill cleanup materials in a location known to all near the designated wash area.
- Ensure that vehicles transporting waste have spill prevention equipment that can prevent spills during transport. Spill prevention equipment includes:
  - Vehicles equipped with baffles for liquid waste
  - Trucks with sealed gates and spill guards for solid waste

***Other Considerations (Limitations and Regulations)***

Hazardous waste cannot be reused or recycled; it must be disposed of by a licensed hazardous waste hauler.

**Requirements*****Costs***

Capital and O&M costs for these programs will vary substantially depending on the size of the facility and the types of waste handled. Costs should be low if there is an inventory program in place.

***Maintenance***

- None except for maintaining equipment for material tracking program.

**Supplemental Information*****Further Detail of the BMP******Land Treatment System***

Minimize runoff of polluted stormwater from land application by:

- Choosing a site where slopes are under 6%, the soil is permeable, there is a low water table, it is located away from wetlands or marshes, and there is a closed drainage system

- Avoiding application of waste to the site when it is raining or when the ground is saturated with water
- Growing vegetation on land disposal areas to stabilize soils and reduce the volume of surface water runoff from the site
- Maintaining adequate barriers between the land application site and the receiving waters (planted strips are particularly good)
- Using erosion control techniques such as mulching and matting, filter fences, straw bales, diversion terracing, and sediment basins
- Performing routine maintenance to ensure the erosion control or site stabilization measures are working

### ***Examples***

The port of Long Beach has a state-of-the-art database for identifying potential pollutant sources, documenting facility management practices, and tracking pollutants.

### **References and Resources**

California's Nonpoint Source Program Plan <http://www.swrcb.ca.gov/nps/index.html>

Clark County Storm Water Pollution Control Manual  
<http://www.co.clark.wa.us/pubworks/bmpman.pdf>

Solid Waste Container Best Management Practices – Fact Sheet On-Line Resources – Environmental Health and Safety. Harvard University. 2002.

King County Storm Water Pollution Control Manual <http://dnr.metrokc.gov/wlr/dss/spcm.htm>

Pollution from Surface Cleaning Folder. 1996. Bay Area Stormwater Management Agencies Association (BASMAA). <http://www.basmaa.org>

Santa Clara Valley Urban Runoff Pollution Prevention Program <http://www.scvurppp.org>

The Storm Water Managers Resource Center <http://www.stormwatercenter.net/>

## Description

Promote the use of less harmful products and products that contain little or no TMDL pollutants. Alternatives exist for most product classes including chemical fertilizers, pesticides, cleaning solutions, janitorial chemicals, automotive and paint products, and consumables (batteries, fluorescent lamps).

## Approach

Pattern a new program after the many established programs around the state and country. Integrate this best management practice as much as possible with existing programs at your facility.

Develop a comprehensive program based on:

- The "Precautionary Principle," which is an alternative to the "Risk Assessment" model that says it's acceptable to use a potentially harmful product until physical evidence of its harmful effects are established and deemed too costly from an environmental or public health perspective. For instance, a risk assessment approach might say it's acceptable to use a pesticide until there is direct proof of an environmental impact. The Precautionary Principle approach is used to evaluate whether a given product is safe, whether it is really necessary, and whether alternative products would perform just as well.
- Environmentally Preferable Purchasing Program to minimize the purchase of products containing hazardous ingredients used in the facility's custodial services, fleet maintenance, and facility maintenance in favor of using alternate products that pose less risk to employees and to the environment.
- Integrated Pest Management (IPM) or Less-Toxic Pesticide Program, which uses a pest management approach that minimizes the use of toxic chemicals and gets rid of pests by methods that pose a lower risk to employees, the public, and the environment.
- Energy Efficiency Program including no-cost and low-cost energy conservation and efficiency actions that can reduce both energy consumption and electricity bills, along with long-term energy efficiency investments.

Consider the following mechanisms for developing and implementing a comprehensive program:

- Policies

## Objectives

- Educate
- Reduce/Minimize
- Product Substitution

## Targeted Constituents

Sediment	
Nutrients	✓
Trash	
Metals	✓
Bacteria	
Oil and Grease	✓
Organics	✓



- Procedures
  - Standard operating procedures (SOPs)
  - Purchasing guidelines and procedures
  - Bid packages (services and supplies)
- Materials
  - Preferred or approved product and supplier lists
  - Product and supplier evaluation criteria
  - Training sessions and manuals
  - Fact sheets for employees

Implement this BMP in conjunction with the Vehicle and Equipment Management fact sheets (SC20 – SC22) and SC41, Building and Grounds Maintenance.

***Training***

- Employees who handle potentially harmful materials in the use of safer alternatives.
- Purchasing departments should be encouraged to procure less hazardous materials and products that contain little or no harmful substances or TMDL pollutants.

***Regulations***

This BMP has no regulatory requirements. Existing regulations already encourage facilities to reduce the use of hazardous materials through incentives such as reduced:

- Specialized equipment storage and handling requirements,
- Storm water runoff sampling requirements,
- Training and licensing requirements, and
- Record keeping and reporting requirements.

***Equipment***

- There are no major equipment requirements to this BMP.

***Limitations***

- Alternative products may not be available, suitable, or effective in every case.

**Requirements*****Cost Considerations***

- The primary cost is for staff time to: 1) develop new policies and procedures and 2) educate purchasing departments and employees who handle potentially harmful materials about the availability, procurement, and use of safer alternatives.

- Some alternative products may be slightly more expensive than conventional products.

## Supplemental Information

Employees and contractors / service providers can both be educated about safer alternatives by using information developed by a number of organizations including the references and resources listed below.

The following discussion provides some general information on safer alternatives. More specific information on particular hazardous materials and the available alternatives may be found in the references and resources listed below.

- Automotive products – Less toxic alternatives are not available for many automotive products, especially engine fluids. But there are alternatives to grease lubricants, car polishes, degreasers, and windshield washer solution. Refined motor oil is also available.
- Vehicle/Trailer lubrication – Fifth wheel bearings on trucks require routine lubrication. Adhesive lubricants are available to replace typical chassis grease.
- Cleaners – Vegetables-based or citrus-based soaps are available to replace petroleum-based soaps/detergents.
- Paint products – Water-based paints, wood preservatives, stains, and finishes are available.
- Pesticides – Specific alternative products or methods exist to control most insects, fungi, and weeds.
- Chemical Fertilizers – Compost and soil amendments are natural alternatives.
- Consumables – Manufacturers have either reduced or are in the process of reducing the amount of heavy metals in consumables such as batteries and fluorescent lamps. All fluorescent lamps contain mercury, however low-mercury containing lamps are now available from most hardware and lighting stores. Fluorescent lamps are also more energy efficient than the average incandescent lamp.
- Janitorial chemicals – Even biodegradable soap can harm fish and wildlife before it biodegrades. Biodegradable does not mean non-toxic. Safer products and procedures are available for floor stripping and cleaning, as well as carpet, glass, metal, and restroom cleaning and disinfecting.

## Examples

There are a number of business and trade associations, and communities with effective programs. Some of the more prominent are listed below in the references and resources section.

## References and Resources

Note: Many of these references provide alternative products for materials that typically are used inside and disposed to the sanitary sewer as well as alternatives to products that usually end up in the storm drain.

***General Sustainable Practices and Pollution Prevention Including Pollutant-Specific Information***

California Department of Toxic Substances Control ([www.dtsc.ca.gov](http://www.dtsc.ca.gov))

California Integrated Waste Management Board ([www.ciwmb.ca.gov](http://www.ciwmb.ca.gov))

City of Santa Monica ([www.santa-monica.org/environment](http://www.santa-monica.org/environment))

City of Palo Alto ([www.city.palo-alto.ca.us/cleanbay](http://www.city.palo-alto.ca.us/cleanbay))

City and County of San Francisco, Department of the Environment  
([www.ci.sf.ca.us/sfenvironment](http://www.ci.sf.ca.us/sfenvironment))

Earth 911 ([www.earth911.org/master.asp](http://www.earth911.org/master.asp))

Environmental Finance Center Region IX ([www.greenstart.org/efc9](http://www.greenstart.org/efc9))

Flex Your Power ([www.flexyourpower.ca.gov](http://www.flexyourpower.ca.gov))

GreenBiz.com ([www.greenbiz.com](http://www.greenbiz.com))

Green Business Program ([www.abag.org/bayarea/enviro/gbus/gb.html](http://www.abag.org/bayarea/enviro/gbus/gb.html))

Pacific Industrial and Business Association ([www.piba.org](http://www.piba.org))

Sacramento Clean Water Business Partners ([www.sacstormwater.org](http://www.sacstormwater.org))

USEPA BMP fact sheet – Alternative products  
([http://cfpub.epa.gov/npdes/stormwater/menuofbmps/poll\\_2.cfm](http://cfpub.epa.gov/npdes/stormwater/menuofbmps/poll_2.cfm))

USEPA Region IX Pollution Prevention Program ([www.epa.gov/region09/p2](http://www.epa.gov/region09/p2))

Western Regional Pollution Prevention Network ([www.westp2net.org](http://www.westp2net.org))

***Metals (mercury, copper)***

National Electrical Manufacturers Association - Environment, Health and Safety  
([www.nema.org](http://www.nema.org))

Sustainable Conservation ([www.suscon.org](http://www.suscon.org))

Auto Recycling Project

Brake Pad Partnership

***Pesticides and Chemical Fertilizers***

Bio-Integral Resource Center ([www.birc.org](http://www.birc.org))

California Department of Pesticide Regulation ([www.cdpr.ca.gov](http://www.cdpr.ca.gov))

University of California Statewide IPM Program ([www.ipm.ucdavis.edu/default.html](http://www.ipm.ucdavis.edu/default.html))

## *Dioxins*

Bay Area Dioxins Project (<http://dioxin.abag.ca.gov/>)



## Description

Stormwater runoff from building and grounds maintenance activities can be contaminated with toxic hydrocarbons in solvents, fertilizers and pesticides, suspended solids, heavy metals, abnormal pH, and oils and greases. Utilizing the protocols in this fact sheet will prevent or reduce the discharge of pollutants to stormwater from building and grounds maintenance activities by washing and cleaning up with as little water as possible, following good landscape management practices, preventing and cleaning up spills immediately, keeping debris from entering the storm drains, and maintaining the stormwater collection system.

## Approach

Reduce potential for pollutant discharge through source control pollution prevention and BMP implementation. Successful implementation depends on effective training of employees on applicable BMPs and general pollution prevention strategies and objectives.

## Pollution Prevention

- Switch to non-toxic chemicals for maintenance when possible.
- Choose cleaning agents that can be recycled.
- Encourage proper lawn management and landscaping, including use of native vegetation.

## Objectives

- Cover
- Contain
- Educate
- Reduce/Minimize
- Product Substitution

## Targeted Constituents

Sediment	✓
Nutrients	✓
Trash	
Metals	✓
Bacteria	✓
Oil and Grease	
Organics	



# SC-41 Building & Grounds Maintenance

---

- Encourage use of Integrated Pest Management techniques for pest control.
- Encourage proper onsite recycling of yard trimmings.
- Recycle residual paints, solvents, lumber, and other material as much as possible.

## ***Suggested Protocols***

### *Pressure Washing of Buildings, Rooftops, and Other Large Objects*

- In situations where soaps or detergents are used and the surrounding area is paved, pressure washers must use a water collection device that enables collection of wash water and associated solids. A sump pump, wet vacuum or similarly effective device must be used to collect the runoff and loose materials. The collected runoff and solids must be disposed of properly.
- If soaps or detergents are not used, and the surrounding area is paved, wash runoff does not have to be collected but must be screened. Pressure washers must use filter fabric or some other type of screen on the ground and/or in the catch basin to trap the particles in wash water runoff.
- If you are pressure washing on a grassed area (with or without soap), runoff must be dispersed as sheet flow as much as possible, rather than as a concentrated stream. The wash runoff must remain on the grass and not drain to pavement.

### *Landscaping Activities*

- Dispose of grass clippings, leaves, sticks, or other collected vegetation as garbage, or by composting. Do not dispose of collected vegetation into waterways or storm drainage systems.
- Use mulch or other erosion control measures on exposed soils.

### *Building Repair, Remodeling, and Construction*

- Do not dump any toxic substance or liquid waste on the pavement, the ground, or toward a storm drain.
- Use ground or drop cloths underneath outdoor painting, scraping, and sandblasting work, and properly dispose of collected material daily.
- Use a ground cloth or oversized tub for activities such as paint mixing and tool cleaning.
- Clean paintbrushes and tools covered with water-based paints in sinks connected to sanitary sewers or in portable containers that can be dumped into a sanitary sewer drain. Brushes and tools covered with non-water-based paints, finishes, or other materials must be cleaned in a manner that enables collection of used solvents (e.g., paint thinner, turpentine, etc.) for recycling or proper disposal.
- Use a storm drain cover, filter fabric, or similarly effective runoff control mechanism if dust, grit, wash water, or other pollutants may escape the work area and enter a catch basin. This is particularly necessary on rainy days. The containment device(s) must be in place at the beginning of the work day, and accumulated dirty runoff and solids must be collected and disposed of before removing the containment device(s) at the end of the work day.

- If you need to de-water an excavation site, you may need to filter the water before discharging to a catch basin or off-site. If directed off-site, you should direct the water through hay bales and filter fabric or use other sediment filters or traps.
- Store toxic material under cover during precipitation events and when not in use. A cover would include tarps or other temporary cover material.

### *Mowing, Trimming, and Planting*

- Dispose of leaves, sticks, or other collected vegetation as garbage, by composting or at a permitted landfill. Do not dispose of collected vegetation into waterways or storm drainage systems.
- Use mulch or other erosion control measures when soils are exposed.
- Place temporarily stockpiled material away from watercourses and drain inlets, and berm or cover stockpiles to prevent material releases to the storm drain system.
- Consider an alternative approach when bailing out muddy water: do not put it in the storm drain; pour over landscaped areas.
- Use hand weeding where practical.

### *Fertilizer and Pesticide Management*

- Follow all federal, state, and local laws and regulations governing the use, storage, and disposal of fertilizers and pesticides and training of applicators and pest control advisors.
- Use less toxic pesticides that will do the job when applicable. Avoid use of copper-based pesticides if possible.
- Do not use pesticides if rain is expected.
- Do not mix or prepare pesticides for application near storm drains.
- Use the minimum amount needed for the job.
- Calibrate fertilizer distributors to avoid excessive application.
- Employ techniques to minimize off-target application (e.g., spray drift) of pesticides, including consideration of alternative application techniques.
- Apply pesticides only when wind speeds are low.
- Fertilizers should be worked into the soil rather than dumped or broadcast onto the surface.
- Irrigate slowly to prevent runoff and then only as much as is needed.
- Clean pavement and sidewalk if fertilizer is spilled on these surfaces before applying irrigation water.
- Dispose of empty pesticide containers according to the instructions on the container label.

# SC-41 Building & Grounds Maintenance

---

- Use up the pesticides. Rinse containers, and use rinse water as product. Dispose of unused pesticide as hazardous waste.
- Implement storage requirements for pesticide products with guidance from the local fire department and County Agricultural Commissioner. Provide secondary containment for pesticides.

## *Inspection*

- Inspect irrigation system periodically to ensure that the right amount of water is being applied and that excessive runoff is not occurring. Minimize excess watering and repair leaks in the irrigation system as soon as they are observed.

## *Training*

- Educate and train employees on pesticide use and in pesticide application techniques to prevent pollution.
- Train employees and contractors in proper techniques for spill containment and cleanup.
- Be sure the frequency of training takes into account the complexity of the operations and the nature of the staff.

## *Spill Response and Prevention*

- Keep your Spill Prevention Control and Countermeasure (SPCC) Plan up-to-date.
- Place a stockpile of spill cleanup materials, such as brooms, dustpans, and vacuum sweepers (if desired) near the storage area where it will be readily accessible.
- Have employees trained in spill containment and cleanup present during the loading/unloading of dangerous wastes, liquid chemicals, or other materials.
- Familiarize employees with the Spill Prevention Control and Countermeasure Plan.
- Clean up spills immediately.

## *Other Considerations*

Alternative pest/weed controls may not be available, suitable, or effective in many cases.

## **Requirements**

### *Costs*

- Cost will vary depending on the type and size of facility.
- Overall costs should be low in comparison to other BMPs.

### *Maintenance*

Sweep paved areas regularly to collect loose particles. Wipe up spills with rags and other absorbent material immediately, do not hose down the area to a storm drain.

## Supplemental Information

### *Further Detail of the BMP*

#### *Fire Sprinkler Line Flushing*

Building fire sprinkler line flushing may be a source of non-stormwater runoff pollution. The water entering the system is usually potable water, though in some areas it may be non-potable reclaimed wastewater. There are subsequent factors that may drastically reduce the quality of the water in such systems. Black iron pipe is usually used since it is cheaper than potable piping, but it is subject to rusting and results in lower quality water. Initially, the black iron pipe has an oil coating to protect it from rusting between manufacture and installation; this will contaminate the water from the first flush but not from subsequent flushes. Nitrates, poly-phosphates and other corrosion inhibitors, as well as fire suppressants and antifreeze may be added to the sprinkler water system. Water generally remains in the sprinkler system a long time (typically a year) and between flushes may accumulate iron, manganese, lead, copper, nickel, and zinc. The water generally becomes anoxic and contains living and dead bacteria and breakdown products from chlorination. This may result in a significant BOD problem and the water often smells. Consequently dispose fire sprinkler line flush water into the sanitary sewer. Do not allow discharge to storm drain or infiltration due to potential high levels of pollutants in fire sprinkler line water.

## References and Resources

California's Nonpoint Source Program Plan <http://www.swrcb.ca.gov/nps/index.html>

Clark County Storm Water Pollution Control Manual  
<http://www.co.clark.wa.us/pubworks/bmpman.pdf>

King County Storm Water Pollution Control Manual <http://dnr.metrokc.gov/wlr/dss/spcm.htm>

Mobile Cleaners Pilot Program: Final Report. 1997. Bay Area Stormwater Management Agencies Association (BASMAA). <http://www.basmaa.org/>

Pollution from Surface Cleaning Folder. 1996. Bay Area Stormwater Management Agencies Association (BASMAA). <http://www.basmaa.org/>

Santa Clara Valley Urban Runoff Pollution Prevention Program <http://www.scvurppp.org>

The Storm Water Managers Resource Center <http://www.stormwatercenter.net/>



## Description

Modifications are common particularly at large industrial sites. The activity may vary from minor and normal building repair to major remodeling, or the construction of new facilities. These activities can generate pollutants including solvents, paints, paint and varnish removers, finishing residues, spent thinners, soap cleaners, kerosene, asphalt and concrete materials, adhesive residues, and old asbestos installation. Protocols in this fact sheet are intended to prevent or reduce the discharge of pollutants to stormwater from building repair, remodeling, and construction by using soil erosion controls, enclosing or covering building material storage areas, using good housekeeping practices, using safer alternative products, and training employees.

## Approach

### *Pollution Prevention*

- Recycle residual paints, solvents, lumber, and other materials to the maximum extent practical.
- Buy recycled products to the maximum extent practical.
- Inform on-site contractors of company policy on these matters and include appropriate provisions in their contract to ensure certain proper housekeeping and disposal practices are implemented.

## Objectives

- Cover
- Contain
- Educate
- Reduce/Minimize
- Recycle

## Targeted Constituents

Sediment	✓
Nutrients	
Trash	✓
Metals	✓
Bacteria	
Oil and Grease	✓
Organics	✓



# SC-42 Building Repair and Construction

---

- Make sure that nearby storm drains are well marked to minimize the chance of inadvertent disposal of residual paints and other liquids.

## ***Suggested Protocols***

### *Repair & Remodeling*

- Follow BMPs identified in Construction BMP Handbook.
- Maintain good housekeeping practices while work is underway.
- Keep the work site clean and orderly. Remove debris in a timely fashion. Sweep the area.
- Cover materials of particular concern that must be left outside, particularly during the rainy season.
- Do not dump waste liquids down the storm drain.
- Dispose of wash water, sweepings, and sediments properly.
- Store materials properly that are normally used in repair and remodeling such as paints and solvents.
- Sweep out the gutter or wash the gutter and trap the particles at the outlet of the downspout if when repairing roofs, small particles have accumulated in the gutter. A sock or geofabric placed over the outlet may effectively trap the materials. If the downspout is tight lined, place a temporary plug at the first convenient point in the storm drain and pump out the water with a vac truck, and clean the catch basin sump where you placed the plug.
- Properly store and dispose waste materials generated from construction activities. See Construction BMP Handbook.
- Clean the storm drain system in the immediate vicinity of the construction activity after it is completed.

### *Painting*

- Enclose painting operations consistent with local air quality regulations and OSHA.
- Local air pollution regulations may, in many areas of the state, specify painting procedures which if properly carried out are usually sufficient to protect water quality.
- Develop paint handling procedures for proper use, storage, and disposal of paints.
- Transport paint and materials to and from job sites in containers with secure lids and tied down to the transport vehicle.
- Test and inspect spray equipment prior to starting to paint. Tighten all hoses and connections and do not overfill paint containers.
- Mix paint indoors before using so that any spill will not be exposed to rain. Do so even during dry weather because cleanup of a spill will never be 100% effective.
- Transfer and load paint and hot thermoplastic away from storm drain inlets.

- Do not transfer or load paint near storm drain inlets.
- Plug nearby storm drain inlets prior to starting painting and remove plugs when job is complete when there is significant risk of a spill reaching storm drains.
- Cover nearby storm drain inlets prior to starting work if sand blasting is used to remove paint.
- Use a ground cloth to collect the chips if painting requires scraping or sand blasting of the existing surface. Dispose the residue properly.
- Cover or enclose painting operations properly to avoid drift.
- Clean the application equipment in a sink that is connected to the sanitary sewer if using water based paints.
- Capture all cleanup-water and dispose of properly.
- Dispose of paints containing lead or tributyl tin and considered a hazardous waste properly.
- Store leftover paints if they are to be kept for the next job properly, or dispose properly.
- Recycle paint when possible. Dispose of paint at an appropriate household hazardous waste facility.

## ***Training***

Proper education of off-site contractors is often overlooked. The conscientious efforts of well trained employees can be lost by unknowing off-site contractors, so make sure they are well informed about what they are expected to do.

## ***Spill Response and Prevention***

- Keep your Spill Prevention Control and Countermeasure (SPCC) Plan up-to-date.
- Place a stockpile of spill cleanup materials where it will be readily accessible.
- Clean up spills immediately.
- Excavate and remove the contaminated (stained) soil if a spill occurs on dirt.

## ***Limitations***

- This BMP is for minor construction only. The State's General Construction Activity Stormwater Permit has more requirements for larger projects. The companion "Construction Best Management Practice Handbook" contains specific guidance and best management practices for larger-scale projects.
- Hazardous waste that cannot be reused or recycled must be disposed of by a licensed hazardous waste hauler.
- Be certain that actions to help stormwater quality are consistent with Cal- and Fed-OSHA and air quality regulations.

# SC-42 Building Repair and Construction

---

## Requirements

### *Costs*

These BMPs are generally low to modest in cost.

### *Maintenance*

N/A

## Supplemental Information

### *Further Detail of the BMP*

#### *Soil/Erosion Control*

If the work involves exposing large areas of soil, employ the appropriate soil erosion and control techniques. See the Construction Best Management Practice Handbook. If old buildings are being torn down and not replaced in the near future, stabilize the site using measures described in SC-40 Contaminated or Erodible Areas.

If a building is to be placed over an open area with a storm drainage system, make sure the storm inlets within the building are covered or removed, or the storm line is connected to the sanitary sewer. If because of the remodeling a new drainage system is to be installed or the existing system is to be modified, consider installing catch basins as they serve as effective “in-line” treatment devices. See Treatment Control Fact Sheet TC-20 Wet Pond/Basin in Section 5 of the New Development and Redevelopment Handbook regarding design criteria. Include in the catch basin a “turn-down” elbow or similar device to trap floatables.

## References and Resources

California’s Nonpoint Source Program Plan <http://www.swrcb.ca.gov/nps/index.html>

Clark County Storm Water Pollution Control Manual  
<http://www.co.clark.wa.us/pubworks/bmpman.pdf>

King County Storm Water Pollution Control Manual <http://dnr.metrokc.gov/wlr/dss/spcm.htm>

Santa Clara Valley Urban Runoff Pollution Prevention Program <http://www.scvurppp.org>

The Storm Water Managers Resource Center <http://www.stormwatercenter.net/>

# Parking/Storage Area Maintenance SC-43



## Description

Parking lots and storage areas can contribute a number of substances, such as trash, suspended solids, hydrocarbons, oil and grease, and heavy metals that can enter receiving waters through stormwater runoff or non-stormwater discharges. The protocols in this fact sheet are intended to prevent or reduce the discharge of pollutants from parking/storage areas and include using good housekeeping practices, following appropriate cleaning BMPs, and training employees.

## Approach

The goal of this program is to ensure stormwater pollution prevention practices are considered when conducting activities on or around parking areas and storage areas to reduce potential for pollutant discharge to receiving waters. Successful implementation depends on effective training of employees on applicable BMPs and general pollution prevention strategies and objectives.

## Pollution Prevention

- Encourage alternative designs and maintenance strategies for impervious parking lots. (See New Development and Redevelopment BMP Handbook)
- Keep accurate maintenance logs to evaluate BMP implementation.

## Objectives

- Cover
- Contain
- Educate
- Reduce/Minimize
- Product Substitution

## Targeted Constituents

Sediment	✓
Nutrients	
Trash	✓
Metals	✓
Bacteria	
Oil and Grease	✓
Organics	✓



# **SC-43 Parking/Storage Area Maintenance**

---

## ***Suggested Protocols***

### *General*

- Keep the parking and storage areas clean and orderly. Remove debris in a timely fashion.
- Allow sheet runoff to flow into biofilters (vegetated strip and swale) and/or infiltration devices.
- Utilize sand filters or oleophilic collectors for oily waste in low quantities.
- Arrange rooftop drains to prevent drainage directly onto paved surfaces.
- Design lot to include semi-permeable hardscape.
- Discharge soapy water remaining in mop or wash buckets to the sanitary sewer through a sink, toilet, clean-out, or wash area with drain.

### *Controlling Litter*

- Post “No Littering” signs and enforce anti-litter laws.
- Provide an adequate number of litter receptacles.
- Clean out and cover litter receptacles frequently to prevent spillage.
- Provide trash receptacles in parking lots to discourage litter.
- Routinely sweep, shovel, and dispose of litter in the trash.

### *Surface Cleaning*

- Use dry cleaning methods (e.g., sweeping, vacuuming) to prevent the discharge of pollutants into the stormwater conveyance system if possible.
- Establish frequency of public parking lot sweeping based on usage and field observations of waste accumulation.
- Sweep all parking lots at least once before the onset of the wet season.
- Follow the procedures below if water is used to clean surfaces:
  - Block the storm drain or contain runoff.
  - Collect and pump wash water to the sanitary sewer or discharge to a pervious surface. Do not allow wash water to enter storm drains.
  - Dispose of parking lot sweeping debris and dirt at a landfill.
- Follow the procedures below when cleaning heavy oily deposits:
  - Clean oily spots with absorbent materials.
  - Use a screen or filter fabric over inlet, then wash surfaces.

# **Parking/Storage Area Maintenance SC-43**

---

- Do not allow discharges to the storm drain.
- Vacuum/pump discharges to a tank or discharge to sanitary sewer.
- Appropriately dispose of spilled materials and absorbents.

## *Surface Repair*

- Preheat, transfer or load hot bituminous material away from storm drain inlets.
- Apply concrete, asphalt, and seal coat during dry weather to prevent contamination from contacting stormwater runoff.
- Cover and seal nearby storm drain inlets where applicable (with waterproof material or mesh) and manholes before applying seal coat, slurry seal, etc. Leave covers in place until job is complete and all water from emulsified oil sealants has drained or evaporated. Clean any debris from these covered manholes and drains for proper disposal.
- Use only as much water as necessary for dust control, to avoid runoff.
- Catch drips from paving equipment that is not in use with pans or absorbent material placed under the machines. Dispose of collected material and absorbents properly.

## *Inspection*

- Have designated personnel conduct inspections of parking facilities and stormwater conveyance systems associated with parking facilities on a regular basis.
- Inspect cleaning equipment/sweepers for leaks on a regular basis.

## *Training*

- Provide regular training to field employees and/or contractors regarding cleaning of paved areas and proper operation of equipment.
- Train employees and contractors in proper techniques for spill containment and cleanup.

## *Spill Response and Prevention*

- Keep your Spill Prevention Control and Countermeasure (SPCC) Plan up-to-date.
- Place a stockpile of spill cleanup materials where it will be readily accessible or at a central location.
- Clean up fluid spills immediately with absorbent rags or material.
- Dispose of spilled material and absorbents properly.

## *Other Considerations*

Limitations related to sweeping activities at large parking facilities may include high equipment costs, the need for sweeper operator training, and the inability of current sweeper technology to remove oil and grease.

# **SC-43 Parking/Storage Area Maintenance**

---

## **Requirements**

### ***Costs***

Cleaning/sweeping costs can be quite large. Construction and maintenance of stormwater structural controls can be quite expensive as well.

### ***Maintenance***

- Sweep parking lot regularly to minimize cleaning with water.
- Clean out oil/water/sand separators regularly, especially after heavy storms.
- Clean parking facilities regularly to prevent accumulated wastes and pollutants from being discharged into conveyance systems during rainy conditions.

## **Supplemental Information**

### ***Further Detail of the BMP***

#### ***Surface Repair***

Apply concrete, asphalt, and seal coat during dry weather to prevent contamination from contacting stormwater runoff. Where applicable, cover and seal nearby storm drain inlets (with waterproof material or mesh) and manholes before applying seal coat, slurry seal, etc. Leave covers in place until job is complete and all water from emulsified oil sealants has drained or evaporated. Clean any debris from these covered manholes and drains for proper disposal. Only use only as much water as is necessary for dust control to avoid runoff.

## **References and Resources**

California's Nonpoint Source Program Plan <http://www.swrcb.ca.gov/nps/index.html>

Clark County Storm Water Pollution Control Manual  
<http://www.co.clark.wa.us/pubworks/bmpman.pdf>

King County Storm Water Pollution Control Manual <http://dnr.metrokc.gov/wlr/dss/spcm.htm>

Pollution from Surface Cleaning Folder. 1996. Bay Area Stormwater Management Agencies Association (BASMAA). <http://www.basmaa.org/>

Oregon Association of Clean Water Agencies. Oregon Municipal Stormwater Toolbox for Maintenance Practices. June 1998.

Santa Clara Valley Urban Runoff Pollution Prevention Program <http://www.scvurppp.org>

The Storm Water Managers Resource Center <http://www.stormwatercenter.net/>



---

## Objectives

---

- Cover
- Contain
- Educate
- Reduce/Minimize

## Description

As a consequence of its function, the stormwater conveyance system collects and transports urban runoff and stormwater that may contain certain pollutants. The protocols in this fact sheet are intended to reduce pollutants reaching receiving waters through proper conveyance system operation and maintenance.

## Approach

### *Pollution Prevention*

Maintain catch basins, stormwater inlets, and other stormwater conveyance structures on a regular basis to remove pollutants, reduce high pollutant concentrations during the first flush of storms, prevent clogging of the downstream conveyance system, restore catch basins' sediment trapping capacity, and ensure the system functions properly hydraulically to avoid flooding.

### *Suggested Protocols*

#### *Catch Basins/Inlet Structures*

- Staff should regularly inspect facilities to ensure compliance with the following:
  - Immediate repair of any deterioration threatening structural integrity.
  - Cleaning before the sump is 40% full. Catch basins should be cleaned as frequently as needed to meet this standard.
  - Stenciling of catch basins and inlets (see SC34 Waste Handling and Disposal).

---

## Targeted Constituents

---

Sediment	✓
Nutrients	
Trash	✓
Metals	
Bacteria	✓
Oil and Grease	
Organics	



# SC-44      Drainage System Maintenance

---

- Clean catch basins, storm drain inlets, and other conveyance structures before the wet season to remove sediments and debris accumulated during the summer.
- Conduct inspections more frequently during the wet season for problem areas where sediment or trash accumulates more often. Clean and repair as needed.
- Keep accurate logs of the number of catch basins cleaned.
- Store wastes collected from cleaning activities of the drainage system in appropriate containers or temporary storage sites in a manner that prevents discharge to the storm drain.
- Dewater the wastes if necessary with outflow into the sanitary sewer if permitted. Water should be treated with an appropriate filtering device prior to discharge to the sanitary sewer. If discharge to the sanitary sewer is not allowed, water should be pumped or vacuumed to a tank and properly disposed. Do not dewater near a storm drain or stream.

## *Storm Drain Conveyance System*

- Locate reaches of storm drain with deposit problems and develop a flushing schedule that keeps the pipe clear of excessive buildup.
- Collect and pump flushed effluent to the sanitary sewer for treatment whenever possible.

## *Pump Stations*

- Clean all storm drain pump stations prior to the wet season to remove silt and trash.
- Do not allow discharge to reach the storm drain system when cleaning a storm drain pump station or other facility.
- Conduct routine maintenance at each pump station.
- Inspect, clean, and repair as necessary all outlet structures prior to the wet season.

## *Open Channel*

- Modify storm channel characteristics to improve channel hydraulics, increase pollutant removals, and enhance channel/creek aesthetic and habitat value.
- Conduct channel modification/improvement in accordance with existing laws. Any person, government agency, or public utility proposing an activity that will change the natural (emphasis added) state of any river, stream, or lake in California, must enter into a Stream or Lake Alteration Agreement with the Department of Fish and Game. The developer-applicant should also contact local governments (city, county, special districts), other state agencies (SWRCB, RWQCB, Department of Forestry, Department of Water Resources), and Federal Corps of Engineers and USFWS.

## *Illicit Connections and Discharges*

- Look for evidence of illegal discharges or illicit connections during routine maintenance of conveyance system and drainage structures:
  - Is there evidence of spills such as paints, discoloring, etc?

- Are there any odors associated with the drainage system?
- Record locations of apparent illegal discharges/illicit connections?
- Track flows back to potential dischargers and conduct aboveground inspections. This can be done through visual inspection of upgradient manholes or alternate techniques including zinc chloride smoke testing, fluorometric dye testing, physical inspection testing, or television camera inspection.
- Eliminate the discharge once the origin of flow is established.
- Stencil or demarcate storm drains, where applicable, to prevent illegal disposal of pollutants. Storm drain inlets should have messages such as “Dump No Waste Drains to Stream” stenciled next to them to warn against ignorant or intentional dumping of pollutants into the storm drainage system.
- Refer to fact sheet SC-10 Non-Stormwater Discharges.

### *Illegal Dumping*

- Inspect and clean up hot spots and other storm drainage areas regularly where illegal dumping and disposal occurs.
- Establish a system for tracking incidents. The system should be designed to identify the following:
  - Illegal dumping hot spots
  - Types and quantities (in some cases) of wastes
  - Patterns in time of occurrence (time of day/night, month, or year)
  - Mode of dumping (abandoned containers, “midnight dumping” from moving vehicles, direct dumping of materials, accidents/spills)
  - Responsible parties
- Post “No Dumping” signs in problem areas with a phone number for reporting dumping and disposal. Signs should also indicate fines and penalties for illegal dumping.
- Refer to fact sheet SC-10 Non-Stormwater Discharges.

### *Training*

- Train crews in proper maintenance activities, including record keeping and disposal.
- Allow only properly trained individuals to handle hazardous materials/wastes.
- Have staff involved in detection and removal of illicit connections trained in the following:
  - OSHA-required Health and Safety Training (29 CFR 1910.120) plus annual refresher training (as needed).

- OSHA Confined Space Entry training (Cal-OSHA Confined Space, Title 8 and Federal OSHA 29 CFR 1910.146).
- Procedural training (field screening, sampling, smoke/dye testing, TV inspection).

***Spill Response and Prevention***

- Investigate all reports of spills, leaks, and/or illegal dumping promptly.
- Clean up all spills and leaks using “dry” methods (with absorbent materials and/or rags) or dig up, remove, and properly dispose of contaminated soil.
- Refer to fact sheet SC-11 Spill Prevention, Control, and Cleanup.

***Other Considerations (Limitations and Regulations)***

- Clean-up activities may create a slight disturbance for local aquatic species. Access to items and material on private property may be limited. Trade-offs may exist between channel hydraulics and water quality/riparian habitat. If storm channels or basins are recognized as wetlands, many activities, including maintenance, may be subject to regulation and permitting.
- Storm drain flushing is most effective in small diameter pipes (36-inch diameter pipe or less, depending on water supply and sediment collection capacity). Other considerations associated with storm drain flushing may include the availability of a water source, finding a downstream area to collect sediments, liquid/sediment disposal, and prohibition against disposal of flushed effluent to sanitary sewer in some areas.
- Regulations may include adoption of substantial penalties for illegal dumping and disposal.
- Local municipal codes may include sections prohibiting discharge of soil, debris, refuse, hazardous wastes, and other pollutants into the storm drain system.

**Requirements*****Costs***

- An aggressive catch basin cleaning program could require a significant capital and O&M budget.
- The elimination of illegal dumping is dependent on the availability, convenience, and cost of alternative means of disposal. The primary cost is for staff time. Cost depends on how aggressively a program is implemented. Other cost considerations for an illegal dumping program include:
  - Purchase and installation of signs.
  - Rental of vehicle(s) to haul illegally-disposed items and material to landfills.
  - Rental of heavy equipment to remove larger items (e.g., car bodies) from channels.
  - Purchase of landfill space to dispose of illegally-dumped items and material.

- Methods used for illicit connection detection (smoke testing, dye testing, visual inspection, and flow monitoring) can be costly and time-consuming. Site-specific factors, such as the level of impervious area, the density and ages of buildings, and type of land use will determine the level of investigation necessary.

## ***Maintenance***

- Two-person teams may be required to clean catch basins with vacuor trucks.
- Teams of at least two people plus administrative personnel are required to identify illicit discharges, depending on the complexity of the storm sewer system.
- Arrangements must be made for proper disposal of collected wastes.
- Technical staff are required to detect and investigate illegal dumping violations.

## **Supplemental Information**

### ***Further Detail of the BMP***

#### ***Storm Drain Flushing***

Flushing is a common maintenance activity used to improve pipe hydraulics and to remove pollutants in storm drainage systems. Flushing may be designed to hydraulically convey accumulated material to strategic locations, such as an open channel, another point where flushing will be initiated, or the sanitary sewer and the treatment facilities, thus preventing resuspension and overflow of a portion of the solids during storm events. Flushing prevents “plug flow” discharges of concentrated pollutant loadings and sediments. Deposits can hinder the designed conveyance capacity of the storm drain system and potentially cause backwater conditions in severe cases of clogging.

Storm drain flushing usually takes place along segments of pipe with grades that are too flat to maintain adequate velocity to keep particles in suspension. An upstream manhole is selected to place an inflatable device that temporarily plugs the pipe. Further upstream, water is pumped into the line to create a flushing wave. When the upstream reach of pipe is sufficiently full to cause a flushing wave, the inflated device is rapidly deflated with the assistance of a vacuum pump, thereby releasing the backed up water and resulting in the cleaning of the storm drain segment.

To further reduce impacts of stormwater pollution, a second inflatable device placed well downstream may be used to recollect the water after the force of the flushing wave has dissipated. A pump may then be used to transfer the water and accumulated material to the sanitary sewer for treatment. In some cases, an interceptor structure may be more practical or required to recollect the flushed waters.

It has been found that cleansing efficiency of periodic flush waves is dependent upon flush volume, flush discharge rate, sewer slope, sewer length, sewer flow rate, sewer diameter, and population density. As a rule of thumb, the length of line to be flushed should not exceed 700 feet. At this maximum recommended length, the percent removal efficiency ranges between 65-75% for organics and 55-65% for dry weather grit/inorganic material. The percent removal efficiency drops rapidly beyond that. Water is commonly supplied by a water truck, but fire hydrants can also supply water. To make the best use of water, it is recommended that reclaimed water be used or that fire hydrant line flushing coincide with storm sewer flushing.

# SC-44      Drainage System Maintenance

---

## References and Resources

California's Nonpoint Source Program Plan <http://www.swrcb.ca.gov/nps/index.html>

Clark County Storm Water Pollution Control Manual  
<http://www.co.clark.wa.us/pubworks/bmpman.pdf>

Ferguson, B.K. 1991. Urban Stream Reclamation, p. 324-322, Journal of Soil and Water Conservation.

King County Storm Water Pollution Control Manual <http://dnr.metrokc.gov/wlr/dss/spcm.htm>

Oregon Association of Clean Water Agencies. Oregon Municipal Stormwater Toolbox for Maintenance Practices. June 1998.

Santa Clara Valley Urban Runoff Pollution Prevention Program <http://www.scvurppp.org>

The Storm Water Managers Resource Center <http://www.stormwatercenter.net>

United States Environmental Protection Agency (USEPA). 2002. Pollution Prevention/Good Housekeeping for Municipal Operations Storm Drain System Cleaning. On line:  
[http://www.epa.gov/npdes/menuofbmps/poll\\_16.htm](http://www.epa.gov/npdes/menuofbmps/poll_16.htm)

## General Description

Drain inserts are manufactured filters or fabric placed in a drop inlet to remove sediment and debris. There are a multitude of inserts of various shapes and configurations, typically falling into one of three different groups: socks, boxes, and trays. The sock consists of a fabric, usually constructed of polypropylene. The fabric may be attached to a frame or the grate of the inlet holds the sock. Socks are meant for vertical (drop) inlets. Boxes are constructed of plastic or wire mesh. Typically a polypropylene “bag” is placed in the wire mesh box. The bag takes the form of the box. Most box products are one box; that is, the setting area and filtration through media occur in the same box. Some products consist of one or more trays or mesh grates. The trays may hold different types of media. Filtration media vary by manufacturer. Types include polypropylene, porous polymer, treated cellulose, and activated carbon.

## Inspection/Maintenance Considerations

Washout problems increase with rain intensity. Susceptibility of accumulated sediments to be re-suspended at low flow rates, can be corrected with an energy dissipater between gate and treatment areas.

Inspection Activities	Suggested Frequency
<ul style="list-style-type: none"> <li>Inspect for sediment buildup and proper functioning.</li> </ul>	At the beginning of the wet season and after significant storms
<ul style="list-style-type: none"> <li>Verify that stormwater enters the unit and does not leak around the perimeter.</li> </ul>	After construction.
Maintenance Activities	Suggested Frequency
<ul style="list-style-type: none"> <li>Remove sediment as needed.</li> </ul>	At the beginning of the wet season and as necessary

## Maintenance Concerns, Objectives, and Goals

- Sediment Removal

## Targeted Constituents

- ✓ Sediment
- ✓ Nutrients
- ✓ Trash
- ✓ Metals
- ✓ Bacteria
- ✓ Oil and Grease
- ✓ Organics

### Removal Effectiveness

See New Development and Redevelopment Handbook-Section 5.



# Site Design & Landscape Planning SD-10



---

## Design Objectives

---

- Maximize Infiltration
  - Provide Retention
  - Slow Runoff
  - Minimize Impervious Land Coverage
  - Prohibit Dumping of Improper Materials
  - Contain Pollutants
  - Collect and Convey
- 

## Description

Each project site possesses unique topographic, hydrologic, and vegetative features, some of which are more suitable for development than others. Integrating and incorporating appropriate landscape planning methodologies into the project design is the most effective action that can be done to minimize surface and groundwater contamination from stormwater.

## Approach

Landscape planning should couple consideration of land suitability for urban uses with consideration of community goals and projected growth. Project plan designs should conserve natural areas to the extent possible, maximize natural water storage and infiltration opportunities, and protect slopes and channels.

## Suitable Applications

Appropriate applications include residential, commercial and industrial areas planned for development or redevelopment.

## Design Considerations

Design requirements for site design and landscapes planning should conform to applicable standards and specifications of agencies with jurisdiction and be consistent with applicable General Plan and Local Area Plan policies.



# SD-10 Site Design & Landscape Planning

---

## *Designing New Installations*

Begin the development of a plan for the landscape unit with attention to the following general principles:

- Formulate the plan on the basis of clearly articulated community goals. Carefully identify conflicts and choices between retaining and protecting desired resources and community growth.
- Map and assess land suitability for urban uses. Include the following landscape features in the assessment: wooded land, open unwooded land, steep slopes, erosion-prone soils, foundation suitability, soil suitability for waste disposal, aquifers, aquifer recharge areas, wetlands, floodplains, surface waters, agricultural lands, and various categories of urban land use. When appropriate, the assessment can highlight outstanding local or regional resources that the community determines should be protected (e.g., a scenic area, recreational area, threatened species habitat, farmland, fish run). Mapping and assessment should recognize not only these resources but also additional areas needed for their sustenance.

Project plan designs should conserve natural areas to the extent possible, maximize natural water storage and infiltration opportunities, and protect slopes and channels.

## *Conserve Natural Areas during Landscape Planning*

If applicable, the following items are required and must be implemented in the site layout during the subdivision design and approval process, consistent with applicable General Plan and Local Area Plan policies:

- Cluster development on least-sensitive portions of a site while leaving the remaining land in a natural undisturbed condition.
- Limit clearing and grading of native vegetation at a site to the minimum amount needed to build lots, allow access, and provide fire protection.
- Maximize trees and other vegetation at each site by planting additional vegetation, clustering tree areas, and promoting the use of native and/or drought tolerant plants.
- Promote natural vegetation by using parking lot islands and other landscaped areas.
- Preserve riparian areas and wetlands.

## *Maximize Natural Water Storage and Infiltration Opportunities Within the Landscape Unit*

- Promote the conservation of forest cover. Building on land that is already deforested affects basin hydrology to a lesser extent than converting forested land. Loss of forest cover reduces interception storage, detention in the organic forest floor layer, and water losses by evapotranspiration, resulting in large peak runoff increases and either their negative effects or the expense of countering them with structural solutions.
- Maintain natural storage reservoirs and drainage corridors, including depressions, areas of permeable soils, swales, and intermittent streams. Develop and implement policies and

# Site Design & Landscape Planning SD-10

---

regulations to discourage the clearing, filling, and channelization of these features. Utilize them in drainage networks in preference to pipes, culverts, and engineered ditches.

- Evaluating infiltration opportunities by referring to the stormwater management manual for the jurisdiction and pay particular attention to the selection criteria for avoiding groundwater contamination, poor soils, and hydrogeological conditions that cause these facilities to fail. If necessary, locate developments with large amounts of impervious surfaces or a potential to produce relatively contaminated runoff away from groundwater recharge areas.

## *Protection of Slopes and Channels during Landscape Design*

- Convey runoff safely from the tops of slopes.
- Avoid disturbing steep or unstable slopes.
- Avoid disturbing natural channels.
- Stabilize disturbed slopes as quickly as possible.
- Vegetate slopes with native or drought tolerant vegetation.
- Control and treat flows in landscaping and/or other controls prior to reaching existing natural drainage systems.
- Stabilize temporary and permanent channel crossings as quickly as possible, and ensure that increases in run-off velocity and frequency caused by the project do not erode the channel.
- Install energy dissipaters, such as riprap, at the outlets of new storm drains, culverts, conduits, or channels that enter unlined channels in accordance with applicable specifications to minimize erosion. Energy dissipaters shall be installed in such a way as to minimize impacts to receiving waters.
- Line on-site conveyance channels where appropriate, to reduce erosion caused by increased flow velocity due to increases in tributary impervious area. The first choice for linings should be grass or some other vegetative surface, since these materials not only reduce runoff velocities, but also provide water quality benefits from filtration and infiltration. If velocities in the channel are high enough to erode grass or other vegetative linings, riprap, concrete, soil cement, or geo-grid stabilization are other alternatives.
- Consider other design principles that are comparable and equally effective.

## ***Redeveloping Existing Installations***

Various jurisdictional stormwater management and mitigation plans (SUSMP, WQMP, etc.) define “redevelopment” in terms of amounts of additional impervious area, increases in gross floor area and/or exterior construction, and land disturbing activities with structural or impervious surfaces. The definition of “redevelopment” must be consulted to determine whether or not the requirements for new development apply to areas intended for redevelopment. If the definition applies, the steps outlined under “designing new installations” above should be followed.

# **SD-10 Site Design & Landscape Planning**

---

Redevelopment may present significant opportunity to add features which had not previously been implemented. Examples include incorporation of depressions, areas of permeable soils, and swales in newly redeveloped areas. While some site constraints may exist due to the status of already existing infrastructure, opportunities should not be missed to maximize infiltration, slow runoff, reduce impervious areas, disconnect directly connected impervious areas.

## **Other Resources**

A Manual for the Standard Urban Stormwater Mitigation Plan (SUSMP), Los Angeles County Department of Public Works, May 2002.

Stormwater Management Manual for Western Washington, Washington State Department of Ecology, August 2001.

Model Standard Urban Storm Water Mitigation Plan (SUSMP) for San Diego County, Port of San Diego, and Cities in San Diego County, February 14, 2002.

Model Water Quality Management Plan (WQMP) for County of Orange, Orange County Flood Control District, and the Incorporated Cities of Orange County, Draft February 2003.

Ventura Countywide Technical Guidance Manual for Stormwater Quality Control Measures, July 2002.



## Design Objectives

- Maximize Infiltration
- Provide Retention
- Slow Runoff
- Minimize Impervious Land Coverage
- Prohibit Dumping of Improper Materials
- Contain Pollutants
- Collect and Convey

## Description

Irrigation water provided to landscaped areas may result in excess irrigation water being conveyed into stormwater drainage systems.

## Approach

Project plan designs for development and redevelopment should include application methods of irrigation water that minimize runoff of excess irrigation water into the stormwater conveyance system.

## Suitable Applications

Appropriate applications include residential, commercial and industrial areas planned for development or redevelopment. (Detached residential single-family homes are typically excluded from this requirement.)

## Design Considerations

### ***Designing New Installations***

The following methods to reduce excessive irrigation runoff should be considered, and incorporated and implemented where determined applicable and feasible by the Permittee:

- Employ rain-triggered shutoff devices to prevent irrigation after precipitation.
- Design irrigation systems to each landscape area's specific water requirements.
- Include design featuring flow reducers or shutoff valves triggered by a pressure drop to control water loss in the event of broken sprinkler heads or lines.
- Implement landscape plans consistent with County or City water conservation resolutions, which may include provision of water sensors, programmable irrigation times (for short cycles), etc.



- Design timing and application methods of irrigation water to minimize the runoff of excess irrigation water into the storm water drainage system.
- Group plants with similar water requirements in order to reduce excess irrigation runoff and promote surface filtration. Choose plants with low irrigation requirements (for example, native or drought tolerant species). Consider design features such as:
  - Using mulches (such as wood chips or bar) in planter areas without ground cover to minimize sediment in runoff
  - Installing appropriate plant materials for the location, in accordance with amount of sunlight and climate, and use native plant materials where possible and/or as recommended by the landscape architect
  - Leaving a vegetative barrier along the property boundary and interior watercourses, to act as a pollutant filter, where appropriate and feasible
  - Choosing plants that minimize or eliminate the use of fertilizer or pesticides to sustain growth
- Employ other comparable, equally effective methods to reduce irrigation water runoff.

### ***Redeveloping Existing Installations***

Various jurisdictional stormwater management and mitigation plans (SUSMP, WQMP, etc.) define “redevelopment” in terms of amounts of additional impervious area, increases in gross floor area and/or exterior construction, and land disturbing activities with structural or impervious surfaces. The definition of “redevelopment” must be consulted to determine whether or not the requirements for new development apply to areas intended for redevelopment. If the definition applies, the steps outlined under “designing new installations” above should be followed.

### **Other Resources**

A Manual for the Standard Urban Stormwater Mitigation Plan (SUSMP), Los Angeles County Department of Public Works, May 2002.

Model Standard Urban Storm Water Mitigation Plan (SUSMP) for San Diego County, Port of San Diego, and Cities in San Diego County, February 14, 2002.

Model Water Quality Management Plan (WQMP) for County of Orange, Orange County Flood Control District, and the Incorporated Cities of Orange County, Draft February 2003.

Ventura Countywide Technical Guidance Manual for Stormwater Quality Control Measures, July 2002.



## Design Objectives

- Maximize Infiltration
- Provide Retention
- Slow Runoff
- Minimize Impervious Land Coverage
- Prohibit Dumping of Improper Materials
- Contain Pollutants
- Collect and Convey

## Description

Waste materials dumped into storm drain inlets can have severe impacts on receiving and ground waters. Posting notices regarding discharge prohibitions at storm drain inlets can prevent waste dumping. Storm drain signs and stencils are highly visible source controls that are typically placed directly adjacent to storm drain inlets.

## Approach

The stencil or affixed sign contains a brief statement that prohibits dumping of improper materials into the urban runoff conveyance system. Storm drain messages have become a popular method of alerting the public about the effects of and the prohibitions against waste disposal.

## Suitable Applications

Stencils and signs alert the public to the destination of pollutants discharged to the storm drain. Signs are appropriate in residential, commercial, and industrial areas, as well as any other area where contributions or dumping to storm drains is likely.

## Design Considerations

Storm drain message markers or placards are recommended at all storm drain inlets within the boundary of a development project. The marker should be placed in clear sight facing toward anyone approaching the inlet from either side. All storm drain inlet locations should be identified on the development site map.

## *Designing New Installations*

The following methods should be considered for inclusion in the project design and show on project plans:

- Provide stenciling or labeling of all storm drain inlets and catch basins, constructed or modified, within the project area with prohibitive language. Examples include “NO DUMPING



– DRAINS TO OCEAN” and/or other graphical icons to discourage illegal dumping.

- Post signs with prohibitive language and/or graphical icons, which prohibit illegal dumping at public access points along channels and creeks within the project area.

Note - Some local agencies have approved specific signage and/or storm drain message placards for use. Consult local agency stormwater staff to determine specific requirements for placard types and methods of application.

### ***Redeveloping Existing Installations***

Various jurisdictional stormwater management and mitigation plans (SUSMP, WQMP, etc.) define “redevelopment” in terms of amounts of additional impervious area, increases in gross floor area and/or exterior construction, and land disturbing activities with structural or impervious surfaces. If the project meets the definition of “redevelopment”, then the requirements stated under “designing new installations” above should be included in all project design plans.

### **Additional Information**

#### ***Maintenance Considerations***

- Legibility of markers and signs should be maintained. If required by the agency with jurisdiction over the project, the owner/operator or homeowner’s association should enter into a maintenance agreement with the agency or record a deed restriction upon the property title to maintain the legibility of placards or signs.

#### ***Placement***

- Signage on top of curbs tends to weather and fade.
- Signage on face of curbs tends to be worn by contact with vehicle tires and sweeper brooms.

### **Supplemental Information**

#### ***Examples***

- Most MS4 programs have storm drain signage programs. Some MS4 programs will provide stencils, or arrange for volunteers to stencil storm drains as part of their outreach program.

### **Other Resources**

A Manual for the Standard Urban Stormwater Mitigation Plan (SUSMP), Los Angeles County Department of Public Works, May 2002.

Model Standard Urban Storm Water Mitigation Plan (SUSMP) for San Diego County, Port of San Diego, and Cities in San Diego County, February 14, 2002.

Model Water Quality Management Plan (WQMP) for County of Orange, Orange County Flood Control District, and the Incorporated Cities of Orange County, Draft February 2003.

Ventura Countywide Technical Guidance Manual for Stormwater Quality Control Measures, July 2002.



## Design Objectives

- Maximize Infiltration
- Provide Retention
- Slow Runoff
- Minimize Impervious Land Coverage
- Prohibit Dumping of Improper Materials
- Contain Pollutants
- Collect and Convey

## Description

Several measures can be taken to prevent operations at maintenance bays and loading docks from contributing a variety of toxic compounds, oil and grease, heavy metals, nutrients, suspended solids, and other pollutants to the stormwater conveyance system.

## Approach

In designs for maintenance bays and loading docks, containment is encouraged. Preventative measures include overflow containment structures and dead-end sumps. However, in the case of loading docks from grocery stores and warehouse/distribution centers, engineered infiltration systems may be considered.

## Suitable Applications

Appropriate applications include commercial and industrial areas planned for development or redevelopment.

## Design Considerations

Design requirements for vehicle maintenance and repair are governed by Building and Fire Codes, and by current local agency ordinances, and zoning requirements. The design criteria described in this fact sheet are meant to enhance and be consistent with these code requirements.

## *Designing New Installations*

Designs of maintenance bays should consider the following:

- Repair/maintenance bays and vehicle parts with fluids should be indoors; or designed to preclude urban run-on and runoff.
- Repair/maintenance floor areas should be paved with Portland cement concrete (or equivalent smooth impervious surface).



- Repair/maintenance bays should be designed to capture all wash water leaks and spills. Provide impermeable berms, drop inlets, trench catch basins, or overflow containment structures around repair bays to prevent spilled materials and wash-down waters from entering the storm drain system. Connect drains to a sump for collection and disposal. Direct connection of the repair/maintenance bays to the storm drain system is prohibited. If required by local jurisdiction, obtain an Industrial Waste Discharge Permit.
- Other features may be comparable and equally effective.

The following designs of loading/unloading dock areas should be considered:

- Loading dock areas should be covered, or drainage should be designed to preclude urban run-on and runoff.
- Direct connections into storm drains from depressed loading docks (truck wells) are prohibited.
- Below-grade loading docks from grocery stores and warehouse/distribution centers of fresh food items should drain through water quality inlets, or to an engineered infiltration system, or an equally effective alternative. Pre-treatment may also be required.
- Other features may be comparable and equally effective.

### ***Redeveloping Existing Installations***

Various jurisdictional stormwater management and mitigation plans (SUSMP, WQMP, etc.) define “redevelopment” in terms of amounts of additional impervious area, increases in gross floor area and/or exterior construction, and land disturbing activities with structural or impervious surfaces. The definition of “redevelopment” must be consulted to determine whether or not the requirements for new development apply to areas intended for redevelopment. If the definition applies, the steps outlined under “designing new installations” above should be followed.

### **Additional Information**

Stormwater and non-stormwater will accumulate in containment areas and sumps with impervious surfaces. Contaminated accumulated water must be disposed of in accordance with applicable laws and cannot be discharged directly to the storm drain or sanitary sewer system without the appropriate permit.

### **Other Resources**

A Manual for the Standard Urban Stormwater Mitigation Plan (SUSMP), Los Angeles County Department of Public Works, May 2002.

Model Standard Urban Storm Water Mitigation Plan (SUSMP) for San Diego County, Port of San Diego, and Cities in San Diego County, February 14, 2002.

Model Water Quality Management Plan (WQMP) for County of Orange, Orange County Flood Control District, and the Incorporated Cities of Orange County, Draft February 2003.

Ventura Countywide Technical Guidance Manual for Stormwater Quality Control Measures, July 2002.

## Description

Trash storage areas are areas where a trash receptacle (s) are located for use as a repository for solid wastes. Stormwater runoff from areas where trash is stored or disposed of can be polluted. In addition, loose trash and debris can be easily transported by water or wind into nearby storm drain inlets, channels, and/or creeks. Waste handling operations that may be sources of stormwater pollution include dumpsters, litter control, and waste piles.

## Approach

This fact sheet contains details on the specific measures required to prevent or reduce pollutants in stormwater runoff associated with trash storage and handling. Preventative measures including enclosures, containment structures, and impervious pavements to mitigate spills, should be used to reduce the likelihood of contamination.

## Suitable Applications

Appropriate applications include residential, commercial and industrial areas planned for development or redevelopment. (Detached residential single-family homes are typically excluded from this requirement.)

## Design Considerations

Design requirements for waste handling areas are governed by Building and Fire Codes, and by current local agency ordinances and zoning requirements. The design criteria described in this fact sheet are meant to enhance and be consistent with these code and ordinance requirements. Hazardous waste should be handled in accordance with legal requirements established in Title 22, California Code of Regulation.

Wastes from commercial and industrial sites are typically hauled by either public or commercial carriers that may have design or access requirements for waste storage areas. The design criteria in this fact sheet are recommendations and are not intended to be in conflict with requirements established by the waste hauler. The waste hauler should be contacted prior to the design of your site trash collection areas. Conflicts or issues should be discussed with the local agency.

## *Designing New Installations*

Trash storage areas should be designed to consider the following structural or treatment control BMPs:

- Design trash container areas so that drainage from adjoining roofs and pavement is diverted around the area(s) to avoid run-on. This might include berming or grading the waste handling area to prevent run-on of stormwater.
- Make sure trash container areas are screened or walled to prevent off-site transport of trash.

## Design Objectives

- Maximize Infiltration
- Provide Retention
- Slow Runoff
- Minimize Impervious Land Coverage
- Prohibit Dumping of Improper Materials
- Contain Pollutants
- Collect and Convey



- Use lined bins or dumpsters to reduce leaking of liquid waste.
- Provide roofs, awnings, or attached lids on all trash containers to minimize direct precipitation and prevent rainfall from entering containers.
- Pave trash storage areas with an impervious surface to mitigate spills.
- Do not locate storm drains in immediate vicinity of the trash storage area.
- Post signs on all dumpsters informing users that hazardous materials are not to be disposed of therein.

### ***Redeveloping Existing Installations***

Various jurisdictional stormwater management and mitigation plans (SUSMP, WQMP, etc.) define “redevelopment” in terms of amounts of additional impervious area, increases in gross floor area and/or exterior construction, and land disturbing activities with structural or impervious surfaces. The definition of “redevelopment” must be consulted to determine whether or not the requirements for new development apply to areas intended for redevelopment. If the definition applies, the steps outlined under “designing new installations” above should be followed.

### **Additional Information**

#### ***Maintenance Considerations***

The integrity of structural elements that are subject to damage (i.e., screens, covers, and signs) must be maintained by the owner/operator. Maintenance agreements between the local agency and the owner/operator may be required. Some agencies will require maintenance deed restrictions to be recorded of the property title. If required by the local agency, maintenance agreements or deed restrictions must be executed by the owner/operator before improvement plans are approved.

### **Other Resources**

A Manual for the Standard Urban Stormwater Mitigation Plan (SUSMP), Los Angeles County Department of Public Works, May 2002.

Model Standard Urban Storm Water Mitigation Plan (SUSMP) for San Diego County, Port of San Diego, and Cities in San Diego County, February 14, 2002.

Model Water Quality Management Plan (WQMP) for County of Orange, Orange County Flood Control District, and the Incorporated Cities of Orange County, Draft February 2003.

Ventura Countywide Technical Guidance Manual for Stormwater Quality Control Measures, July 2002.

## General Description

Gravity separators: (alternatively, swirl concentrators, swirl or vortex separators, or hydrodynamic separators) are gravity separators, and in principle are essentially wet vaults. The difference from wet vaults, however, is that the gravity separator is round, rather than rectangular, and the water moves in a centrifugal fashion before exiting. By having the water move in a circular fashion, rather than a straight line as is the case with a standard wet vault, it is possible to obtain significant removal of suspended sediments and attached pollutants with less space. They can provide effective pretreatment when paired with filtration devices, such as media filters or bioretention systems.

Gravity separators were originally developed for combined sewer overflows (CSOs), where they are used primarily to remove coarse inorganic solids. Gravity separation has been adapted to stormwater treatment by several manufacturers.

## Inspection/Maintenance Considerations

Gravity separators require routine removal of accumulated sediment, trash, and debris. As some of the systems have standing water that remains between storms, gravity separators can become a nuisance due to mosquito breeding. Also, a loss of dissolved pollutants may occur as accumulated organic matter (e.g., leaves) decomposes in the units.

---

### Advanced BMPs Covered

---



---

### Maintenance Concerns

---

- *Sediment, Trash, and Debris Accumulations*
- *Vector Control*

---

### Targeted Constituents\*

---

<i>Sediment</i>	✓
<i>Nutrients</i>	✓
<i>Trash</i>	✓
<i>Metals</i>	✓
<i>Bacteria</i>	
<i>Oil and Grease</i>	
<i>Organics</i>	

---

*\*Removal Effectiveness varies for different manufacturer designs. See New Development and Redevelopment Handbook-Section 5 for more information.*

---



Inspection Activities	Suggested Frequency
<input type="checkbox"/> Inspect the unit twice during the first wet season of operation, setting the cleaning frequency accordingly.	Post construction
<input type="checkbox"/> Inspect for floating debris, sediment buildup, and accumulated petroleum products.	Annual
<input type="checkbox"/> Contact the local mosquito and vector control agency if mosquito breeding is observed or suspected.	As needed
Maintenance Activities	Suggested Frequency
<input type="checkbox"/> Remove sediment that has accumulated in the vault after construction in the drainage area is complete.	Post construction
<input type="checkbox"/> The recommended frequency of cleaning differs with the manufacturer, ranging from one to two years. <input type="checkbox"/> Maintenance consists of the removal of accumulated material with a vacuum truck. It may be necessary to remove and dispose the floatables separately due to the presence of petroleum product. Annual maintenance is typical.	Annual, or per manufacturers recommendations
<input type="checkbox"/> Remove floating debris and accumulated petroleum products as needed. Floating oil should be removed from wet vaults that are used as oil/water separators when oil accumulation exceeds one inch.	Annual, or more frequent as needed

## References

California Department of Transportation. *Treatment BMP Technology Report (CTSW-RT-09-239.06)*, April, 2010. <http://www.dot.ca.gov/hq/env/stormwater/pdf/CTSW-RT-09-239-06.pdf>.

California Stormwater Quality Association. *Stormwater Best Management Practice Handbook, New Development and Redevelopment*, 2003. <https://www.casqa.org/resources/bmp-handbooks/new-development-redevelopment-bmp-handbook>.

Orange County Stormwater Program. Technical Guidance Document BMP Fact Sheets. [http://media.ocgov.com/gov/pw/watersheds/documents/wqmp/tgd/technical\\_guidance\\_document\\_bmp\\_fact\\_sheets.asp](http://media.ocgov.com/gov/pw/watersheds/documents/wqmp/tgd/technical_guidance_document_bmp_fact_sheets.asp).

San Francisco Public Utilities Commission, et al. San Francisco Stormwater Design Guidelines. Appendix A, Stormwater BMP Fact Sheets, June, 2010. <http://www.sfwater.org/modules/showdocument.aspx?documentid=2778>.

Tahoe Regional Planning Agency. Best Management Practices Handbook, 2012. <http://www.tahoebmp.org/Documents/2012%20BMP%20Handbook.pdf>.

U.S. Environmental Protection Agency, Post-Construction Stormwater Management in New Development and Redevelopment. BMP Fact Sheets. Available at: [http://cfpub.epa.gov/npdes/stormwater/menuofbmps/index.cfm?action=min\\_measure&min\\_measure\\_id=5](http://cfpub.epa.gov/npdes/stormwater/menuofbmps/index.cfm?action=min_measure&min_measure_id=5).

Ventura Countywide Stormwater Quality Management Program. *Technical Guidance Manual for Stormwater Quality Control Measures*, May, 2010.

[http://www.vcstormwater.org/documents/workproducts/technicalguidancemanual/2010revisions/Ventura%20Technical%20Guidance%20Document 5-6-10.pdf](http://www.vcstormwater.org/documents/workproducts/technicalguidancemanual/2010revisions/Ventura%20Technical%20Guidance%20Document%205-6-10.pdf).

# **Attachment F Infiltration Report**

August 8, 2023

CRP/Lovett Chino Industrial Owner, LLC  
120 Newport Center Drive, Suite 217  
Newport Beach, California 92660



**SOUTHERN  
CALIFORNIA  
GEOTECHNICAL**  
*A California Corporation*

Attention: Mr. Tyler Banton  
Market Leader, Southern California

Project No.: **23G101-4**

Subject: **Results of Additional Infiltration Testing**  
Proposed Industrial Development  
13610 Yorba Avenue  
Chino, California

References: 1) Geotechnical Investigation, Proposed Industrial Development, 13610 Yorba Avenue, Chino, California, prepared by Southern California Geotechnical, Inc. (SCG) for Lovett Industrial, SCG Project No. 23G101-1, dated February 20, 2023.

2) Results of Infiltration Testing, Proposed Industrial Development, 13610 Yorba Avenue, Chino, California, prepared by Southern California Geotechnical, Inc. (SCG) for Lovett Industrial, SCG Project No. 23G101-2, dated February 28, 2023.

3) Additional Geotechnical Investigation, Proposed Industrial Development, 13610 Yorba Avenue, Chino, California, prepared by Southern California Geotechnical, Inc. (SCG) for Lovett Industrial, SCG Project No. 23G101-3, dated August 8, 2023.

Mr. Banton:

In accordance with your request, we have conducted additional infiltration testing at the subject site. We are pleased to present this report summarizing the results of the infiltration testing and our design recommendations.

### **Scope of Services**

The scope of services performed for this project was in general accordance with our Change Order No. 23G101-CO2R, dated July 7, 2023. The scope of services included site reconnaissance, subsurface exploration, field testing, and engineering analysis to determine the infiltration rates of the on-site soils. The infiltration testing was performed in general accordance with the guidelines published in the Riverside County – Low Impact Development BMP Design Handbook – Section 2.3 of Appendix A, prepared for the Riverside County Department of Environmental Health (RCDEH), dated December, 2013. The San Bernardino County standards defer to the guidelines published by the RCDEH.

### **Site and Project Description**

The site is located at the northwest corner of Yorba Avenue and Schaefer Avenue in Chino, California. The site is also referenced by the street address of 13610 Yorba Avenue. The site is

bounded to the north by a vacant lot, to the east by Yorba Avenue, to the south by Schaefer Avenue, and to the west by existing commercial/industrial developments. The general location of the site is illustrated on the Site Location Map, included as Plate 1 of this report.

The subject site consists of two rectangular to square-shaped parcels, which total 13.9± acres in size. The southern parcel was previously utilized as a horse ranch and the northern parcel is presently utilized as a truck and trailer parking lot. The horse ranch is developed with an abandoned single-family residence, a shed, a barn and several shade structures. The ground surface cover in the area surrounding the single-family residence, shed, and barn consists of asphaltic concrete pavements. The pavements are in poor condition with moderate to severe cracking throughout. Extensive plant growth was observed within the cracks. The ground surface cover in the horse pen areas consists of exposed soil, moderate native grass and weed growth, and scattered debris and trash. The ground surface cover in the parking lot in the northern area of the site consists of exposed soil and open-graded gravel.

Detailed topographic information was not available at the time of this report. Based on elevations obtained from Google Earth and visual observations made at the time of the subsurface investigation, the site slopes downward toward the southwest at a gradient of 1± percent.

### **Proposed Development**

A conceptual site plan (Scheme 5A), prepared by HPA Architecture, was provided to our office. Based on this plan, the site will be developed with one (1) new industrial building. The proposed building will be 282,337± ft<sup>2</sup> in size and will be located in the western area of the site. Dock-high doors will be constructed along the western portion of the building wall. The building is expected to be surrounded by asphaltic concrete pavements in the parking and drive areas, Portland cement concrete pavements in the truck court areas, and limited areas of concrete flatwork and landscape planters.

The subject site will utilize on-site stormwater disposal. The infiltration system will consist of one (1) below-grade infiltration chamber system located in the western portion of the site. The bottom of the infiltration system will be approximately 18± feet below existing site grades.

### **Concurrent Study**

SCG concurrently conducted an update geotechnical investigation at the subject site, referenced above. As a part of this study, three (3) borings were advanced to depths of 20± feet below the existing site grades. Boring No. B-6 was drilled through pavements consisting of 2± inches of asphaltic concrete with no significant layer of underlying aggregate base. Artificial fill soils were encountered beneath the pavements, dry root mat, or at the ground surface at Boring Nos. B-5 through B-7. The fill soils generally extended to depths of 2½ to 3± feet at boring Nos. B-5 through B-7. Generally, the fill soils encountered at these borings, as well as those encountered during the previous study, consist of loose to medium dense silty sands and clayey sands with varying clay and gravel content, as well as stiff to very stiff clayey silt. Native alluvial soils were encountered beneath the fill soils at Boring Nos. B-5 and B-7, extending to the maximum depth explored of 20± feet. The alluvial soils generally consist of loose to dense sands, silty sands, sandy silts. Boring No. B-2, Trench No. T-1 and T-2 encountered layers of stiff clayey silt and silty

clay. Boring No. B-2 encountered layers of loose silty sands and sandy silts between depths of 5 and 12± feet.

### **Previous Studies**

SCG previously conducted a geotechnical investigation at the subject site (Reference No. 1). As a part of this study, four (4) borings were advanced to depths of 20 to 25± feet below the existing site grades. In addition to the borings, four (4) trenches were excavated to a depth of 10± feet below the existing site grades.

Artificial fill soils were encountered at the ground surface at all of the boring and trench locations. The fill soils generally consist of loose to medium dense silty sands and sandy silts, with trace amounts of clay content, extending to depths of 2 to 4½± feet below existing site grades. These soils possess a disturbed and mottled appearance, resulting in their classification as artificial fill. Native alluvium was encountered beneath the artificial fill soils at all boring and trench locations, extending to at least the maximum depth explored of 25± feet. The alluvial soils generally consist of medium dense to dense silty sands, sandy silts and sands with trace amounts of clay, silt and fine to coarse gravel and stiff clayey silts and silty clays.

SCG also previously conducted infiltration testing at the subject site (Reference No. 2). As part of this study, seven (7) infiltration test borings (identified as Infiltration Test Nos. I-1 through I-7) were advanced to a depth of 12± feet below existing site grades.

Asphaltic concrete, 3± inches in thickness, was encountered at the ground surface at Infiltration Boring No. I-2. Native alluvial soils were encountered beneath the pavements or at the ground surface at all of the boring locations, extending to at least the maximum depth explored of 12± feet. The alluvium generally consists of loose to medium dense silty fine sands and silty fine to medium sands.

At the time of this report, SCG recommended the following infiltration rates:

<b>Infiltration System</b>	<b>Location</b>	<b>Design Infiltration Rate (Inches per Hour)</b>
"A"	North	Not Recommended
"B"	Central-North	0.3*
"C"	Central-South	4.5*
"D"	South	4.0*

### **Groundwater**

Free water was not encountered during the drilling of the borings or excavation of the trenches. Based on the lack of water within the borings and trenches, and the moisture contents of the recovered soil samples, the static groundwater is considered to have existed at a depth in excess of 25± feet at the time of our subsurface explorations.

Recent water level data was obtained from the California State Water Resources Control Board, GeoTracker, website, <https://geotracker.waterboards.ca.gov/>. The nearest monitoring well is located approximately 2150 feet southeast of the site. Water level readings within this monitoring well indicate high groundwater levels of 49± feet below the ground surface in June 2007.

## **Subsurface Exploration**

### Scope of Exploration

The subsurface exploration conducted for the infiltration testing consisted of three (3) infiltration test borings, advanced to a depth of 18± feet below the existing site grades. The infiltration borings were advanced using a truck-mounted drilling rig, equipped with 8-inch-diameter hollow-stem augers and were logged during drilling by a member of our staff. The approximate locations of the infiltration test borings (identified as I-8 through I-10) are indicated on the Infiltration Test Location Plan, enclosed as Plate 2 of this report.

Upon the completion of the infiltration borings, the bottom of each test boring was covered with 2± inches of clean ¾-inch gravel. A sufficient length of 3-inch-diameter perforated PVC casing was then placed into each test hole so that the PVC casing extended from the bottom of the test hole to the ground surface. Clean ¾-inch gravel was then installed in the annulus surrounding the PVC casing.

## **Geotechnical Conditions**

Native alluvium was encountered at the ground surface at all three (3) of the infiltration test borings, extending to at least the maximum explored depth of 18± feet below existing site grades. The alluvium consists of medium dense fine sandy silts, silty fine sands, and silty fine to medium sands. The Boring Logs, which illustrate the conditions encountered at the boring locations, are included with this report.

## **Infiltration Testing**

As previously mentioned, the infiltration testing was performed in general accordance with the guidelines published in Riverside County – Low Impact Development BMP Design Handbook – Section 2.3 of Appendix A, which apply to San Bernardino County.

### Pre-soaking

In accordance with the county infiltration standards, all of the infiltration test borings were pre-soaked prior to the infiltration testing. The pre-soaking process consisted of filling the test borings by inverting a full 5-gallon bottle of clear water supported over each hole so that the water level reaches a level of at least 5 times the hole's radius above the gravel at the bottom of each hole. The pre-soaking was completed after all of the water had percolated through each test hole or after 15 hours since initiating the pre-soak.

## Infiltration Testing

Following the pre-soaking process of the infiltration test borings, SCG performed the infiltration testing. Each test hole was filled with water to a depth of at least 5 times the hole's radius above the gravel at the bottom of each test hole, and less than or equal to the water level used during the pre-soaking process. In accordance with the San Bernardino County guidelines, since "sandy-soils" were encountered at the bottom of the borings, readings were taken at 10-minute intervals for a total of 1 hour. After each reading, the borings were refilled to the correct water level above the gravel at the bottom of each test hole. The water level readings are presented on the spreadsheets enclosed with this report. The infiltration rates for each of the timed intervals are also tabulated on the spreadsheets.

The infiltration rates from the test are tabulated in inches per hour. In accordance with the typically accepted practice, it is recommended that the most conservative reading from the latter part of the infiltration tests be used as the design infiltration rate. The rates are summarized below:

<b><u>Infiltration Test No.</u></b>	<b><u>Depth (feet)</u></b>	<b><u>Soil Description</u></b>	<b><u>Measured Infiltration Rate (inches/hour)</u></b>
I-8	18	Silty fine to medium Sand, little fine Gravel, trace coarse Sand	6.8
I-9	18	Silty fine to coarse Sand, trace fine Gravel with 3±-inch fine Sandy Silt lens	5.7
I-10	18	Silty fine Sand, trace medium Sand	8.7

## **Laboratory Testing**

### Moisture Content

The moisture contents for the recovered soil samples within the borings were determined in accordance with ASTM D-2216 and are expressed as a percentage of the dry weight. These test results are presented on the Boring Logs.

### Grain Size Analysis

The grain size distribution of selected soils collected from the base of each infiltration test boring have been determined using a range of wire mesh screens. These tests were performed in general accordance with ASTM D-422 and/or ASTM D-1140. The weight of the portion of the sample retained on each screen is recorded and the percentage finer or coarser of the total weight is calculated. The results of these tests are presented on Plates C-1 through C-3 of this report.

## **Design Recommendations**

Three (3) infiltration tests were performed at the subject site. As noted above, the infiltration rates at these locations vary from 5.7 to 8.7 inches per hour. Based on the infiltration test results,

we recommend an infiltration rate of 5.7 inches per hour to be utilized in the design of the proposed below-grade chamber system.

The design of the storm water infiltration system should be performed by the project civil engineer, in accordance with the City of Chino and/or San Bernadino guidelines. It is recommended that the system be constructed so as to facilitate removal of silt and clay, or other deleterious materials from any water that may enter the system. The presence of such materials would decrease the effective infiltration rates. **It is recommended that the project civil engineer apply an appropriate factor of safety. The infiltration rate recommended above is based on the assumption that only clean water will be introduced to the subsurface profile. Any fines, debris, or organic materials could significantly impact the infiltration rate.** It should be noted that the recommended infiltration rate is based on infiltration testing at three (3) discrete locations and that the overall infiltration rate of the proposed infiltration system could vary considerably.

### **Infiltration Rate Considerations**

The infiltration rate presented herein was determined in accordance with the San Bernardino County guidelines and is considered valid only for the time and place of the actual test. Varying subsurface conditions will exist in other areas of the site, which could alter the recommended infiltration rate presented above. The infiltration rate will decline over time between maintenance cycles as silt or clay particles accumulate on the BMP surface. The infiltration rate is highly dependent upon a number of factors, including density, silt and clay content, grain size distribution throughout the range of particle sizes, and particle shape. Small changes in these factors can cause large changes in the infiltration rate.

Infiltration rates are based on unsaturated flow. As water is introduced into soils by infiltration, the soils become saturated and the wetting front advances from the unsaturated zone to the saturated zone. Once the soils become saturated, infiltration rates become zero, and water can only move through soils by hydraulic conductivity at a rate determined by pressure head and soil permeability. Changes in soil moisture content will affect the infiltration rate. Infiltration rates should be expected to decrease until the soils become saturated. Soil permeability values will then govern groundwater movement. Permeability values may be on the order of 10 to 20 times less than infiltration rates. The system designer should incorporate adequate factors of safety and allow for overflow design into appropriate traditional storm drain systems, which would transport storm water off-site.

### **Construction Considerations**

The infiltration rates presented in this report are specific to the tested locations and tested depths. Infiltration rates can be significantly reduced if the soils are exposed to excessive disturbance or compaction during construction. Compaction of the soils at the bottom of the infiltration system can significantly reduce the infiltration ability of the basins. Therefore, the subgrade soils within proposed infiltration system areas should not be over-excavated, undercut or compacted in any significant manner. **It is recommended that a note to this effect be added to the project plans and/or specifications.**

We recommend that a representative from the geotechnical engineer be on-site during the construction of the proposed infiltration system to identify the soil classification at the base of the system. It should be confirmed that the soils at the base of the proposed infiltration system correspond with those presented in this report to ensure that the performance of the system will be consistent with the rate reported herein.

We recommend that scrapers and other rubber-tired heavy equipment not be operated on the basin bottom, or at levels lower than 2 feet above the bottom of the system, particularly within basins. As such, the bottom 24 inches of the infiltration system should be excavated with non-rubber-tired equipment, such as excavators.

### **Chamber Maintenance**

The proposed project will include infiltration chambers. Water flowing into these chambers will carry some level of sediment. This layer has the potential to significantly reduce the infiltration rate of the chamber subgrade soils. Therefore, a formal chamber maintenance program should be established to ensure that these silt and clay deposits are removed from the chamber on a regular basis.

### **Location of Infiltration Systems**

The use of on-site storm water infiltration systems carries a risk of creating adverse geotechnical conditions. Increasing the moisture content of the soil can cause the soil to lose internal shear strength and increase its compressibility, resulting in a change in the designed engineering properties. Overlying structures and pavements in the infiltration area could potentially be damaged due to saturation of the subgrade soils. **The proposed infiltration system for this site should be located at least 25 feet away from any structures, including retaining walls.** Even with this provision of locating the infiltration system at least 25 feet from the building(s), it is possible that infiltrating water into the subsurface soils could have an adverse effect on the proposed or existing structures. It should also be noted that utility trenches which happen to collect storm water can also serve as conduits to transmit storm water toward the structure, depending on the slope of the utility trench. Therefore, consideration should also be given to the proposed locations of underground utilities which may pass near the proposed infiltration system.

The infiltration system designer should also give special consideration to the effect that the proposed infiltration system may have on nearby subterranean structures, open excavations, or descending slopes. In particular, infiltration systems should not be located near the crest of descending slopes, particularly where the slopes are comprised of granular soils. Such systems will require specialized design and analysis to evaluate the potential for slope instability, piping failures and other phenomena that typically apply to earthen dam design. This type of analysis is beyond the scope of this infiltration test report, but these factors should be considered by the infiltration system designer when locating the infiltration systems.

### **General Comments**

This report has been prepared as an instrument of service for use by the client in order to aid in the evaluation of this property and to assist the architects and engineers in the design and

preparation of the project plans and specifications. This report may be provided to the contractor(s) and other design consultants to disclose information relative to the project. However, this report is not intended to be utilized as a specification in and of itself, without appropriate interpretation by the project architect, structural engineer, and/or civil engineer. The design of the proposed storm water infiltration system is the responsibility of the civil engineer. The role of the geotechnical engineer is limited to determination of infiltration rate only. By using the design infiltration rate contained herein, the civil engineer agrees to indemnify, defend, and hold harmless the geotechnical engineer for all aspects of the design and performance of the proposed storm water infiltration system. The reproduction and distribution of this report must be authorized by the client and Southern California Geotechnical, Inc. Furthermore, any reliance on this report by an unauthorized third party is at such party's sole risk, and we accept no responsibility for damage or loss which may occur.

The analysis of this site was based on a subsurface profile interpolated from limited discrete soil samples. While the materials encountered in the project area are considered to be representative of the total area, some variations should be expected between boring locations and testing depths. If the conditions encountered during construction vary significantly from those detailed herein, we should be contacted immediately to determine if the conditions alter the recommendations contained herein.

This report has been based on assumed or provided characteristics of the proposed development. It is recommended that the owner, client, architect, structural engineer, and civil engineer carefully review these assumptions to ensure that they are consistent with the characteristics of the proposed development. If discrepancies exist, they should be brought to our attention to verify that they do not affect the conclusions and recommendations contained herein. We also recommend that the project plans and specifications be submitted to our office for review to verify that our recommendations have been correctly interpreted. The analysis, conclusions, and recommendations contained within this report have been promulgated in accordance with generally accepted professional geotechnical engineering practice. No other warranty is implied or expressed.

**Closure**

We sincerely appreciate the opportunity to be of service on this project. We look forward to providing additional consulting services during the course of the project. If we may be of further assistance in any manner, please contact our office.

Respectfully Submitted,

SOUTHERN CALIFORNIA GEOTECHNICAL, INC.



Ryan Bremer  
Staff Geologist



Robert G. Trazo, GE 2655  
Principal Engineer



Distribution: (1) Addressee

- Enclosures:
- Plate 1 - Site Location Map
  - Plate 2 - Infiltration Test Location Plan
  - Boring Log Legend and Logs (5 pages)
  - Infiltration Test Results Spreadsheets (3 pages)
  - Grain Size Distribution Graphs (3 pages)

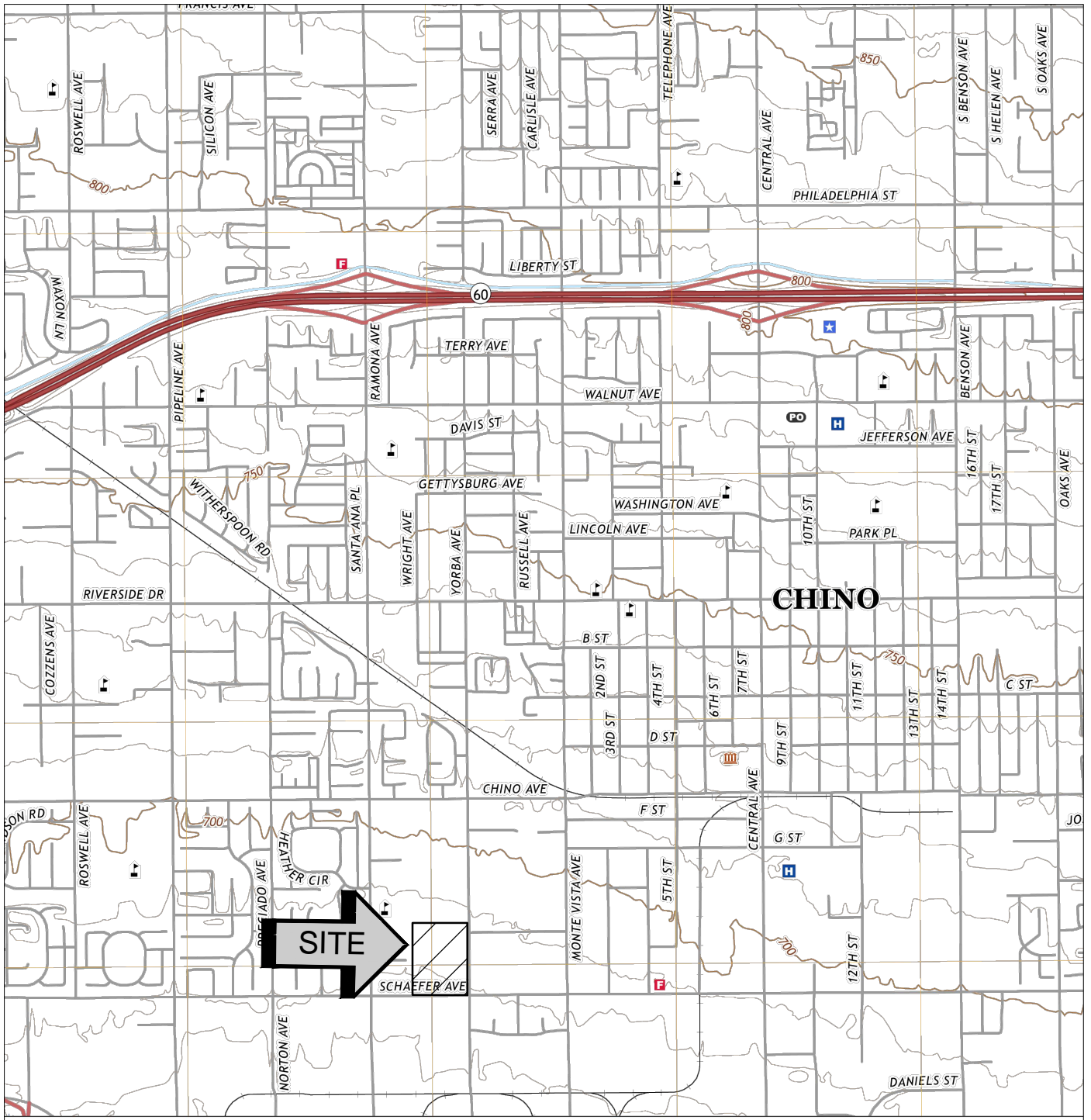





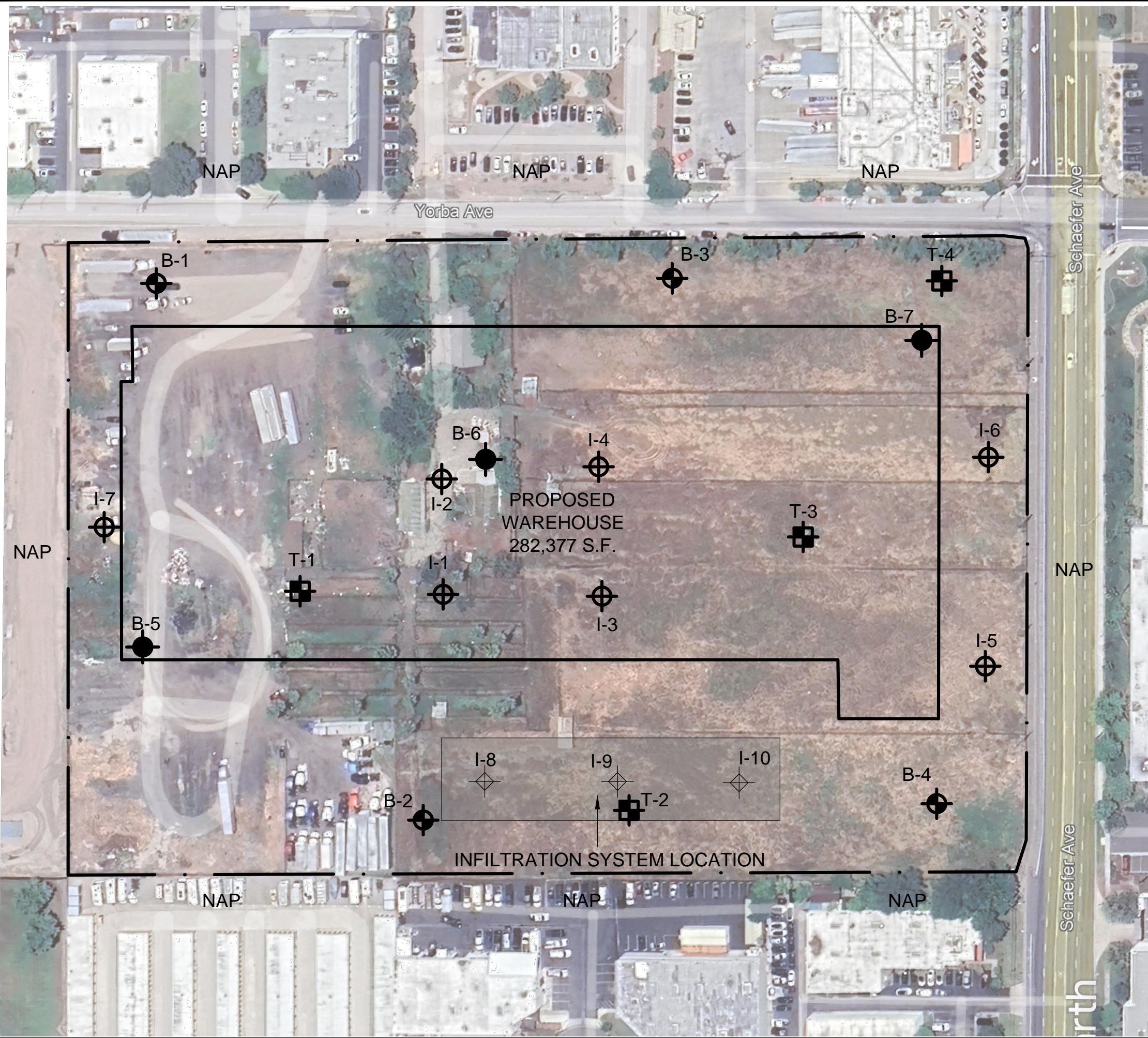

SOURCE: USGS TOPOGRAPHIC MAP OF THE ONTARIO QUADRANGLE, SAN BERNARDINO COUNTY, CALIFORNIA, 2021.



<b>SITE LOCATION MAP</b>	
PROPOSED INDUSTRIAL DEVELOPMENT	
CHINO, CALIFORNIA	
SCALE: 1" = 2000'	 <b>SOUTHERN CALIFORNIA GEOTECHNICAL</b>
DRAWN: RB	
CHKD: RGT	
SCG PROJECT 23G101-4	
<b>PLATE 1</b>	









### GEOTECHNICAL LEGEND

-  APPROXIMATE INFILTRATION TEST LOCATION
-  CONCURRENT BORING LOCATION (SCG PROJECT NO. 23G101-3)
-  PREVIOUS INFILTRATION LOCATION (SCG PROJECT NO. 23G101-2)
-  PREVIOUS BORING LOCATION (SCG PROJECT NO. 23G101-1)
-  PREVIOUS TRENCH LOCATION (SCG PROJECT NO. 23G101-1)
-  - - - PROPERTY LINE

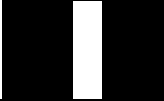
NOTE: AERIAL PHOTOGRAPH OBTAINED FROM GOOGLE EARTH.  
SITE PLAN PROVIDED BY HPA ARCHITECTURE.

<b>INFILTRATION TEST LOCATION PLAN</b>	
PROPOSED INDUSTRIAL DEVELOPMENT	
CHINO, CALIFORNIA	
SCALE: 1" = 100'	
DRAWN: RB	
CHKD: RGT	
SCG PROJECT 23G101-4	
PLATE 2	<b>SOUTHERN CALIFORNIA GEOTECHNICAL</b>

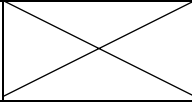
# BORING LOG LEGEND

SAMPLE TYPE	GRAPHICAL SYMBOL	SAMPLE DESCRIPTION
AUGER		SAMPLE COLLECTED FROM AUGER CUTTINGS, NO FIELD MEASUREMENT OF SOIL STRENGTH. (DISTURBED)
CORE		ROCK CORE SAMPLE: TYPICALLY TAKEN WITH A DIAMOND-TIPPED CORE BARREL. TYPICALLY USED ONLY IN HIGHLY CONSOLIDATED BEDROCK.
GRAB		SOIL SAMPLE TAKEN WITH NO SPECIALIZED EQUIPMENT, SUCH AS FROM A STOCKPILE OR THE GROUND SURFACE. (DISTURBED)
CS		CALIFORNIA SAMPLER: 2-1/2 INCH I.D. SPLIT BARREL SAMPLER, LINED WITH 1-INCH HIGH BRASS RINGS. DRIVEN WITH SPT HAMMER. (RELATIVELY UNDISTURBED)
NSR		NO RECOVERY: THE SAMPLING ATTEMPT DID NOT RESULT IN RECOVERY OF ANY SIGNIFICANT SOIL OR ROCK MATERIAL.
SPT		STANDARD PENETRATION TEST: SAMPLER IS A 1.4 INCH INSIDE DIAMETER SPLIT BARREL, DRIVEN 18 INCHES WITH THE SPT HAMMER. (DISTURBED)
SH		SHELBY TUBE: TAKEN WITH A THIN WALL SAMPLE TUBE, PUSHED INTO THE SOIL AND THEN EXTRACTED. (UNDISTURBED)
VANE		VANE SHEAR TEST: SOIL STRENGTH OBTAINED USING A 4 BLADED SHEAR DEVICE. TYPICALLY USED IN SOFT CLAYS-NO SAMPLE RECOVERED.

## COLUMN DESCRIPTIONS

### DEPTH:

Distance in feet below the ground surface.

### SAMPLE:

Sample Type as depicted above.

### BLOW COUNT:

Number of blows required to advance the sampler 12 inches using a 140 lb hammer with a 30-inch drop. 50/3" indicates penetration refusal (>50 blows) at 3 inches. WH indicates that the weight of the hammer was sufficient to push the sampler 6 inches or more.

### POCKET PEN.:

Approximate shear strength of a cohesive soil sample as measured by pocket penetrometer.

### GRAPHIC LOG:

Graphic Soil Symbol as depicted on the following page.

### DRY DENSITY:

Dry density of an undisturbed or relatively undisturbed sample in lbs/ft<sup>3</sup>.

### MOISTURE CONTENT:

Moisture content of a soil sample, expressed as a percentage of the dry weight.

### LIQUID LIMIT:

The moisture content above which a soil behaves as a liquid.

### PLASTIC LIMIT:

The moisture content above which a soil behaves as a plastic.

### PASSING #200 SIEVE:

The percentage of the sample finer than the #200 standard sieve.

### UNCONFINED SHEAR:

The shear strength of a cohesive soil sample, as measured in the unconfined state.

# SOIL CLASSIFICATION CHART

MAJOR DIVISIONS			SYMBOLS		TYPICAL DESCRIPTIONS		
			GRAPH	LETTER			
<p><b>COARSE GRAINED SOILS</b></p> <p>MORE THAN 50% OF MATERIAL IS LARGER THAN NO. 200 SIEVE SIZE</p>	<p><b>GRAVEL AND GRAVELLY SOILS</b></p>	<p>CLEAN GRAVELS</p> <p>(LITTLE OR NO FINES)</p>		<b>GW</b>	WELL-GRADED GRAVELS, GRAVEL - SAND MIXTURES, LITTLE OR NO FINES		
		<p>GRAVELS WITH FINES</p> <p>(APPRECIABLE AMOUNT OF FINES)</p>		<b>GP</b>	POORLY-GRADED GRAVELS, GRAVEL - SAND MIXTURES, LITTLE OR NO FINES		
		<p>MORE THAN 50% OF COARSE FRACTION RETAINED ON NO. 4 SIEVE</p>	<p>GRAVELS WITH FINES</p> <p>(APPRECIABLE AMOUNT OF FINES)</p>		<b>GM</b>	SILTY GRAVELS, GRAVEL - SAND - SILT MIXTURES	
		<p>MORE THAN 50% OF COARSE FRACTION PASSING ON NO. 4 SIEVE</p>	<p>GRAVELS WITH FINES</p> <p>(APPRECIABLE AMOUNT OF FINES)</p>		<b>GC</b>	CLAYEY GRAVELS, GRAVEL - SAND - CLAY MIXTURES	
	<p><b>SAND AND SANDY SOILS</b></p>	<p>CLEAN SANDS</p> <p>(LITTLE OR NO FINES)</p>		<b>SW</b>	WELL-GRADED SANDS, GRAVELLY SANDS, LITTLE OR NO FINES		
				<b>SP</b>	POORLY-GRADED SANDS, GRAVELLY SAND, LITTLE OR NO FINES		
		<p>MORE THAN 50% OF COARSE FRACTION PASSING ON NO. 4 SIEVE</p>	<p>SANDS WITH FINES</p> <p>(APPRECIABLE AMOUNT OF FINES)</p>		<b>SM</b>	SILTY SANDS, SAND - SILT MIXTURES	
					<b>SC</b>	CLAYEY SANDS, SAND - CLAY MIXTURES	
			<p><b>FINE GRAINED SOILS</b></p> <p>MORE THAN 50% OF MATERIAL IS SMALLER THAN NO. 200 SIEVE SIZE</p>	<p><b>SILTS AND CLAYS</b></p> <p>LIQUID LIMIT LESS THAN 50</p>		<b>ML</b>	INORGANIC SILTS AND VERY FINE SANDS, ROCK FLOUR, SILTY OR CLAYEY FINE SANDS OR CLAYEY SILTS WITH SLIGHT PLASTICITY
						<b>CL</b>	INORGANIC CLAYS OF LOW TO MEDIUM PLASTICITY, GRAVELLY CLAYS, SANDY CLAYS, SILTY CLAYS, LEAN CLAYS
	<b>OL</b>	ORGANIC SILTS AND ORGANIC SILTY CLAYS OF LOW PLASTICITY					
<p><b>SILTS AND CLAYS</b></p> <p>LIQUID LIMIT GREATER THAN 50</p>		<b>MH</b>		INORGANIC SILTS, MICACEOUS OR DIATOMACEOUS FINE SAND OR SILTY SOILS			
		<b>CH</b>		INORGANIC CLAYS OF HIGH PLASTICITY			
		<b>OH</b>		ORGANIC CLAYS OF MEDIUM TO HIGH PLASTICITY, ORGANIC SILTS			
<p><b>HIGHLY ORGANIC SOILS</b></p>				<b>PT</b>	PEAT, HUMUS, SWAMP SOILS WITH HIGH ORGANIC CONTENTS		

NOTE: DUAL SYMBOLS ARE USED TO INDICATE BORDERLINE SOIL CLASSIFICATIONS



JOB NO.: 23G101-4	DRILLING DATE: 7/13/23	WATER DEPTH: Dry
PROJECT: Proposed Industrial Development	DRILLING METHOD: Hollow Stem Auger	CAVE DEPTH: ---
LOCATION: Chino, California	LOGGED BY: Michelle Krizek	READING TAKEN: At Completion

FIELD RESULTS				GRAPHIC LOG	DESCRIPTION	LABORATORY RESULTS						COMMENTS
DEPTH (FEET)	SAMPLE	BLOW COUNT	POCKET PEN. (TSF)			DRY DENSITY (PCF)	MOISTURE CONTENT (%)	LIQUID LIMIT	PLASTIC LIMIT	PASSING #200 SIEVE (%)	ORGANIC CONTENT (%)	
SURFACE ELEVATION: --- MSL												
5		9			ALLUVIUM: Dark Brown to Dark Gray Brown fine Sandy Silt, little Clay, little Calcareous veining, trace medium to coarse Sand, trace fine Gravel, loose to medium dense-very moist		14					
10		11			Brown Silty fine Sand, trace medium to coarse Sand, trace fine to coarse Gravel, trace Iron Oxide staining, medium dense-damp		17 9					
15		19			Gray Brown Silty fine to medium Sand, little fine Gravel, trace coarse Sand, 3±-inch fine Sandy Silt lens, medium dense-moist		13		27			
Boring Terminated at 18 feet												

TBL\_23G101-4.GPJ\_SOCALGEO.GDT\_8/8/23



JOB NO.: 23G101-4	DRILLING DATE: 7/13/23	WATER DEPTH: Dry
PROJECT: Proposed Industrial Development	DRILLING METHOD: Hollow Stem Auger	CAVE DEPTH: ---
LOCATION: Chino, California	LOGGED BY: Michelle Krizek	READING TAKEN: At Completion

FIELD RESULTS				GRAPHIC LOG	DESCRIPTION	LABORATORY RESULTS						COMMENTS
DEPTH (FEET)	SAMPLE	BLOW COUNT	POCKET PEN. (TSF)			DRY DENSITY (PCF)	MOISTURE CONTENT (%)	LIQUID LIMIT	PLASTIC LIMIT	PASSING #200 SIEVE (%)	ORGANIC CONTENT (%)	
SURFACE ELEVATION: --- MSL												
5		15			<u>ALLUVIUM</u> : Dark Gray Brown fine Sandy Silt, little Clay, little Calcareous veining and nodules, trace medium Sand, medium dense-very moist		22					
10		15			Gray Brown Silty fine Sand, medium dense-damp		17					
15		24			Brown Silty fine to coarse Sand, trace fine Gravel, 3± inch fine Sandy Silt lens, medium dense-damp		9		13			
					Boring Terminated at 18 feet							

TBL\_23G101-4.GPJ\_SOCALGEO.GDT\_8/8/23



JOB NO.: 23G101-4	DRILLING DATE: 7/13/23	WATER DEPTH: Dry
PROJECT: Proposed Industrial Development	DRILLING METHOD: Hollow Stem Auger	CAVE DEPTH: ---
LOCATION: Chino, California	LOGGED BY: Michelle Krizek	READING TAKEN: At Completion

FIELD RESULTS				GRAPHIC LOG	DESCRIPTION	LABORATORY RESULTS						COMMENTS
DEPTH (FEET)	SAMPLE	BLOW COUNT	POCKET PEN. (TSF)			DRY DENSITY (PCF)	MOISTURE CONTENT (%)	LIQUID LIMIT	PLASTIC LIMIT	PASSING #200 SIEVE (%)	ORGANIC CONTENT (%)	
SURFACE ELEVATION: --- MSL												
5		14			<u>ALLUVIUM</u> : Dark Gray Brown to Gray fine Sandy Silt, little Clay, little Calcareous veining and nodules, trace medium to coarse Sand, medium dense-very moist		18					
10		11			Gray Brown Silty fine Sand, trace medium Sand, trace to little Iron Oxide staining, medium dense-very moist		17					
15		26					18		19			
					Boring Terminated at 18 feet							

TBL 23G101-4.GPJ\_SOCALGEO.GDT 8/8/23

**INFILTRATION CALCULATIONS**

Project Name	Proposed Industrial Development
Project Location	Chino, California
Project Number	23G101-4
Engineer	CB

Test Hole Radius	4 (in)
Test Depth	18.10 (ft)

Infiltration Test Hole	I-8
------------------------	-----

Soil Criteria Test							
Interval Number		Time	Time Interval (min)	Water Depth (ft)	Change in Water Level (in)	Did 6 inches of water seep away in less than 25 minutes?	Sandy Soils or Non-Sandy Soils?
1	Initial	10:54 AM	25.00	16.20	19.56	YES	SANDY SOILS
	Final	11:19 AM		17.83			
2	Initial	11:20 AM	25.00	16.20	18.96	YES	SANDY SOILS
	Final	11:45 AM		17.78			

Test Data							
Interval Number		Time	Time Interval (min)	Water Depth (ft)	Change in Water Level (ft)	Average Head Height (ft)	Infiltration Rate Q (in/hr)
1	Initial	11:47 AM	10.00	16.20	1.01	1.40	7.76
	Final	11:57 AM		17.21			
2	Initial	11:58 AM	10.00	16.20	0.98	1.41	7.46
	Final	12:08 PM		17.18			
3	Initial	12:10 PM	10.00	16.20	0.94	1.43	7.06
	Final	12:20 PM		17.14			
4	Initial	12:29 PM	10.00	16.20	0.92	1.44	6.87
	Final	12:39 PM		17.12			
5	Initial	12:39 PM	10.00	16.20	0.91	1.45	6.78
	Final	12:49 PM		17.11			
6	Initial	12:49 PM	10.00	16.20	0.91	1.45	6.78
	Final	12:59 PM		17.11			

Per County Standards, Infiltration Rate calculated as follows:

$$Q = \frac{\Delta H(60r)}{\Delta t(r + 2H_{avg})}$$

- Where:
- Q = Infiltration Rate (in inches per hour)
  - ΔH = Change in Height (Water Level) over the time interval
  - r = Test Hole (Borehole) Radius
  - Δt = Time Interval
  - H<sub>avg</sub> = Average Head Height over the time interval

**INFILTRATION CALCULATIONS**

Project Name	Proposed Industrial Development
Project Location	Chino, California
Project Number	23G101-4
Engineer	CB

Test Hole Radius	4 (in)
Test Depth	18.10 (ft)

Infiltration Test Hole	I-9
------------------------	-----

Soil Criteria Test							
Interval Number		Time	Time Interval (min)	Water Depth (ft)	Change in Water Level (in)	Did 6 inches of water seep away in less than 25 minutes?	Sandy Soils or Non-Sandy Soils?
1	Initial	10:00 AM	25.00	16.20	24.00	YES	SANDY SOILS
	Final	10:25 AM		18.20			
2	Initial	10:25 AM	25.00	16.20	23.76	YES	SANDY SOILS
	Final	10:50 AM		18.18			

Test Data							
Interval Number		Time	Time Interval (min)	Water Depth (ft)	Change in Water Level (ft)	Average Head Height (ft)	Infiltration Rate Q (in/hr)
1	Initial	10:50 AM	10.00	16.20	1.06	1.37	8.28
	Final	11:00 AM		17.26			
2	Initial	11:01 AM	10.00	16.20	0.83	1.49	6.03
	Final	11:11 AM		17.03			
3	Initial	11:12 AM	10.00	16.20	0.83	1.49	6.03
	Final	11:22 AM		17.03			
4	Initial	11:24 AM	10.00	16.20	0.80	1.50	5.76
	Final	11:34 AM		17.00			
5	Initial	11:34 AM	10.00	16.20	0.79	1.51	5.67
	Final	11:44 AM		16.99			
6	Initial	11:45 AM	10.00	16.20	0.79	1.51	5.67
	Final	11:55 AM		16.99			

Per County Standards, Infiltration Rate calculated as follows:

$$Q = \frac{\Delta H(60r)}{\Delta t(r + 2H_{avg})}$$

- Where:
- Q = Infiltration Rate (in inches per hour)
  - ΔH = Change in Height (Water Level) over the time interval
  - r = Test Hole (Borehole) Radius
  - Δt = Time Interval
  - H<sub>avg</sub> = Average Head Height over the time interval

## INFILTRATION CALCULATIONS

Project Name	Proposed Industrial Development
Project Location	Chino, California
Project Number	23G101-4
Engineer	CB

Test Hole Radius	4 (in)
Test Depth	18.10 (ft)

Infiltration Test Hole	I-10
------------------------	------

Soil Criteria Test							
Interval Number		Time	Time Interval (min)	Water Depth (ft)	Change in Water Level (in)	Did 6 inches of water seep away in less than 25 minutes?	Sandy Soils or Non-Sandy Soils?
1	Initial	8:04 AM	25.00	16.20	24.00	YES	SANDY SOILS
	Final	8:29 AM		18.20			
2	Initial	8:30 AM	25.00	16.20	24.00	YES	SANDY SOILS
	Final	8:55 AM		18.20			

Test Data							
Interval Number		Time	Time Interval (min)	Water Depth (ft)	Change in Water Level (ft)	Average Head Height (ft)	Infiltration Rate Q (in/hr)
1	Initial	9:06 AM	10.00	16.20	1.37	1.22	11.90
	Final	9:16 AM		17.57			
2	Initial	9:19 AM	10.00	16.20	1.19	1.31	9.70
	Final	9:29 AM		17.39			
3	Initial	9:30 AM	10.00	16.20	1.15	1.33	9.25
	Final	9:40 AM		17.35			
4	Initial	9:41 AM	10.00	16.20	1.13	1.34	9.03
	Final	9:51 AM		17.33			
5	Initial	9:51 AM	10.00	16.20	1.11	1.35	8.81
	Final	10:01 AM		17.31			
6	Initial	10:02 AM	10.00	16.20	1.10	1.35	8.70
	Final	10:12 AM		17.30			

Per County Standards, Infiltration Rate calculated as follows:

$$Q = \frac{\Delta H(60r)}{\Delta t(r + 2H_{avg})}$$

- Where:
- Q = Infiltration Rate (in inches per hour)
  - $\Delta H$  = Change in Height (Water Level) over the time interval
  - r = Test Hole (Borehole) Radius
  - $\Delta t$  = Time Interval
  - $H_{avg}$  = Average Head Height over the time interval



# Grain Size Distribution

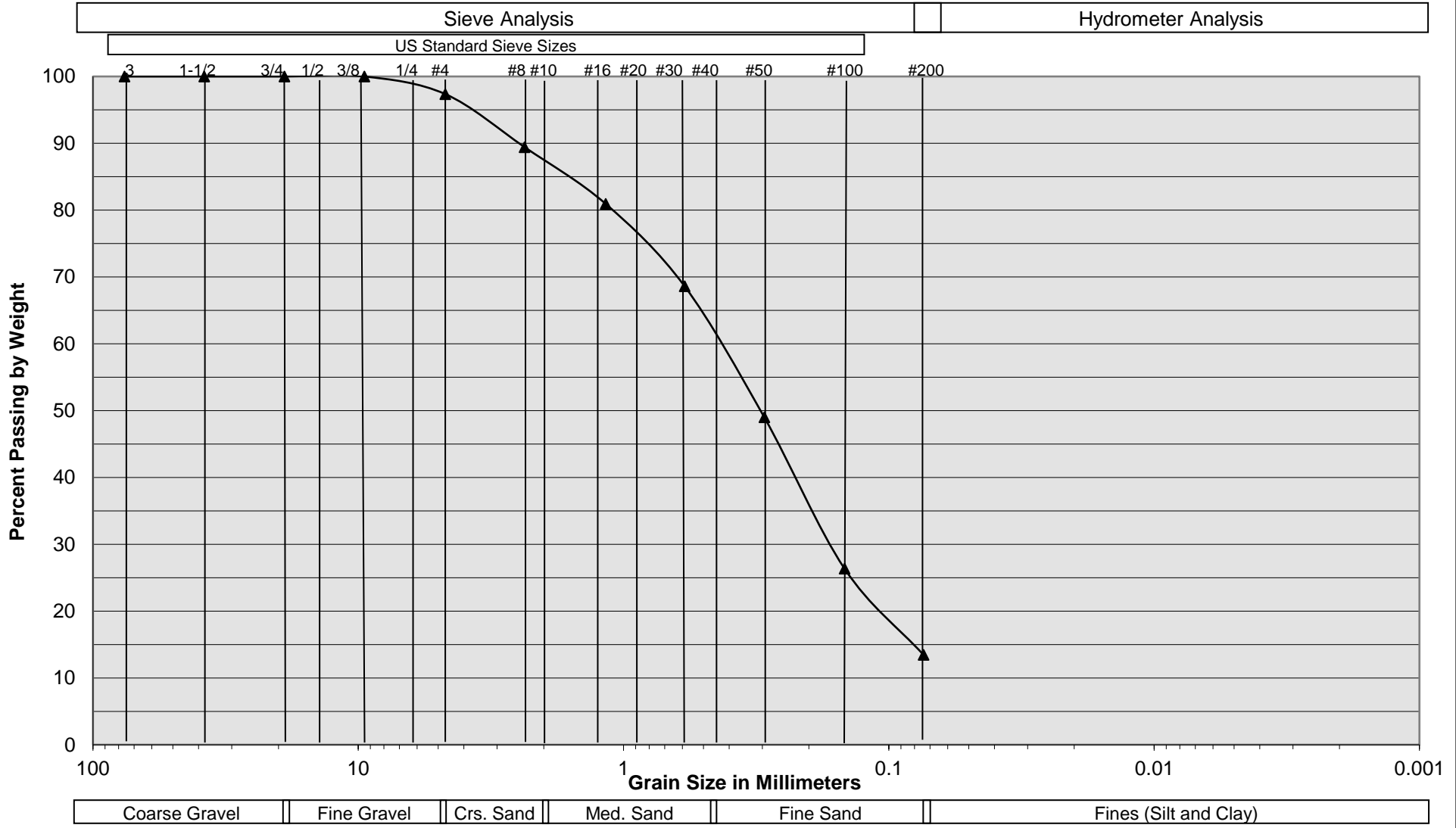

Sample Description	I-9 @ 16½ to 18 feet
Soil Classification	Brown Silty fine to coarse Sand

Proposed Industrial Development  
 Chino, California  
 Project No. 23G101-4  
**PLATE C- 2**



**SOUTHERN CALIFORNIA GEOTECHNICAL**  
A California Corporation

# Grain Size Distribution

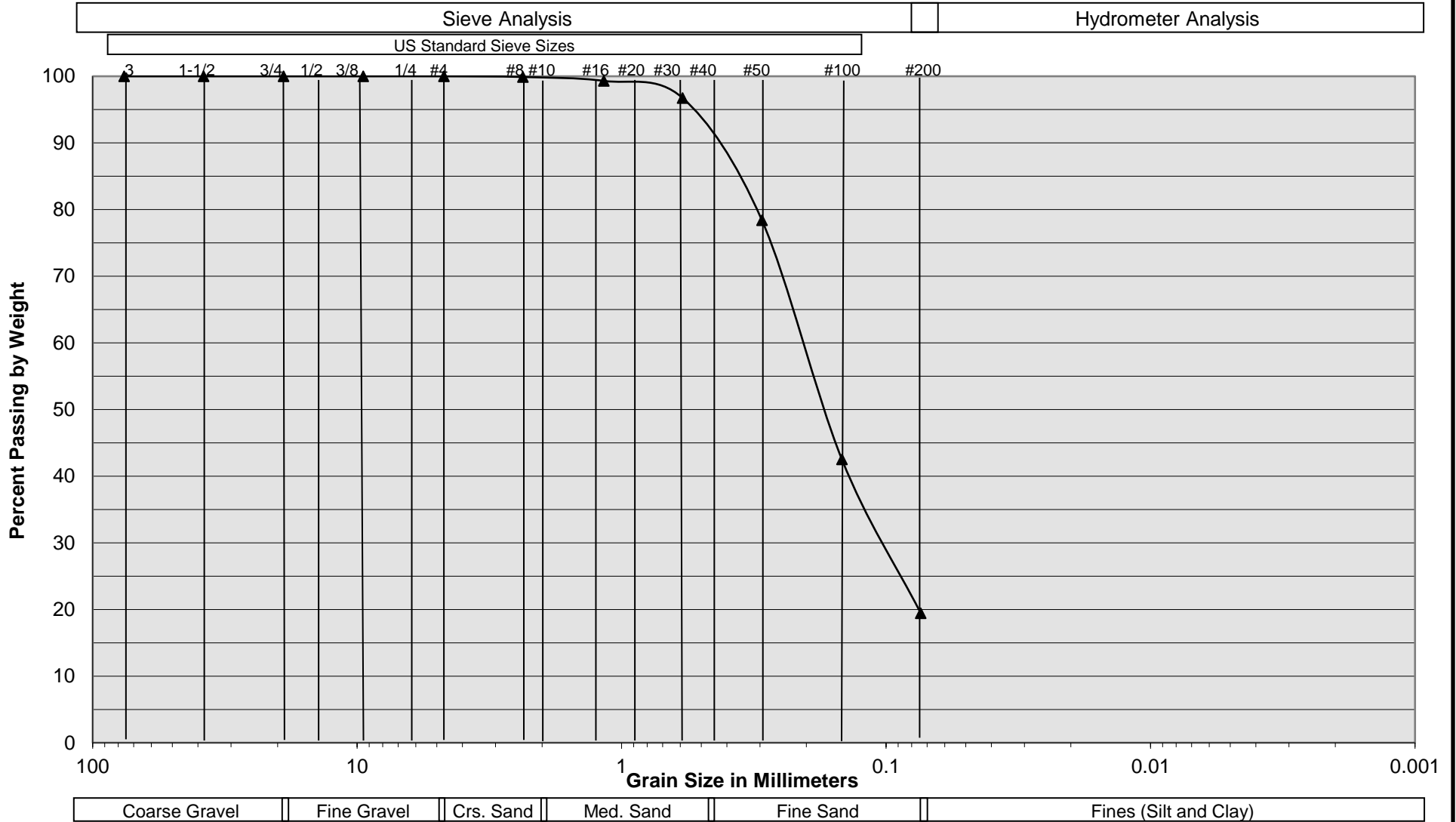

Sample Description	I-10 @ 16½ to 18 feet
Soil Classification	Gray Brown Silty fine Sand, trace medium Sand

Proposed Industrial Development  
 Chino, California  
 Project No. 23G101-4  
**PLATE C- 3**



February 28, 2023

Lovett Industrial  
880 Apollo Street, Suite 301  
El Segundo, California 90245



**SOUTHERN  
CALIFORNIA  
GEOTECHNICAL**  
*A California Corporation*

Attention: Mr. Tyler Banton  
Market Leader, Southern California

Project No.: **23G101-2**

Subject: **Results of Infiltration Testing**  
Proposed Industrial Development  
13610 Yorba Avenue  
Chino, California

Reference: Geotechnical Investigation, Proposed Industrial Development, 13610 Yorba Avenue, Chino, California, prepared by Southern California Geotechnical, Inc. (SCG) for Lovett Industrial, SCG Project No. 23G101-1, dated February 20, 2023.

Mr. Banton:

In accordance with your request, we have conducted infiltration testing at the subject site. We are pleased to present this report summarizing the results of the infiltration testing and our design recommendations.

### **Scope of Services**

The scope of services performed for this project was in general accordance with our Proposal No. 22P446R, dated January 10, 2023. The scope of services included site reconnaissance, subsurface exploration, field testing, and engineering analysis to determine the infiltration rates of the on-site soils. The infiltration testing was performed in general accordance with the guidelines published in the Riverside County – Low Impact Development BMP Design Handbook – Section 2.3 of Appendix A, prepared for the Riverside County Department of Environmental Health (RCDEH), dated December, 2013. The San Bernardino County standards defer to the guidelines published by the RCDEH.

### **Site and Project Description**

The site is located at the northwest corner of Yorba Avenue and Schaefer Avenue in Chino, California. The site is also referenced by the street address of 13610 Yorba Avenue. The site is bounded to the north by a vacant lot, to the east by Yorba Avenue, to the south by Schaefer Avenue, and to the west by existing commercial/industrial developments. The general location of the site is illustrated on the Site Location Map, included as Plate 1 of this report.

The subject site consists of two rectangular to square-shaped parcels, which total 13.9± acres in size. The southern parcel was previously utilized as a horse ranch and the northern parcel is presently utilized as a truck and trailer parking lot. The horse ranch is developed with a single-family residence, a shed, a barn and several shade structures. The ground surface cover in the

area surrounding the single-family residence, shed, and barn consists of asphaltic concrete pavements. The pavements are in poor condition with moderate to severe cracking throughout. The ground surface cover in the horse pen areas consists of exposed soil, moderate native grass and weed growth, and scattered debris and trash. The ground surface cover in the parking lot in the northern area of the site consists of exposed soil and open-graded gravel.

Detailed topographic information was not available at the time of this report. Based on elevations obtained from Google Earth and visual observations made at the time of the subsurface investigation, the site slopes downward toward the southwest at a gradient of 1± percent.

### **Proposed Development**

A conceptual site plan (Scheme 2), prepared by HPA Architecture, was provided to our office. Based on this plan, the site will be developed with two (2) new industrial buildings, identified as Building 1 and Building 2. Building 1 will be 141,910± ft<sup>2</sup> in size and will be located in the north area of the site. Building 2 will be 163,540± ft<sup>2</sup> in size and will be located in the south area of the site. Dock-high doors will be constructed along a portion of at least one building wall. The buildings are expected to be surrounded by asphaltic concrete pavements in the parking and drive areas, Portland cement concrete pavements in the truck court areas, and limited areas of concrete flatwork and landscape planters.

The subject site will utilize on-site stormwater disposal. The infiltration systems will consist of four (4) below-grade infiltration chambers (identified as Infiltration Systems "A" through "D").

<b><u>Infiltration System</u></b>	<b><u>Bottom of System (feet)</u></b>	<b><u>Location</u></b>
A	12	North
B	12	North-Central
C	12	South-Central
D	12	South

### **Concurrent Study**

SCG concurrently conducted a geotechnical investigation at the subject site, referenced above. As a part of this study, four (4) borings were advanced to depths of 20 to 25± feet below the existing site grades. In addition to the borings, four (4) trenches were excavated to a depth of 10± feet below the existing site grades.

Artificial fill soils were encountered at the ground surface at all of the boring and trench locations. The fill soils generally consist of loose to medium dense silty sands and sandy silts, with trace amounts of clay content, extending to depths of 2 to 4½± feet below existing site grades. These soils possess a disturbed and mottled appearance, resulting in their classification as artificial fill. Native alluvium was encountered beneath the artificial fill soils at all boring and trench locations, extending to at least the maximum depth explored of 25± feet. The alluvial soils generally consist of medium dense to dense silty sands, sandy silts and sands with trace amounts of clay, silt and fine to coarse gravel and stiff clayey silts and silty clays.

## Groundwater

Free water was not encountered during the drilling of the borings or excavation of the trenches. Based on the lack of water within the borings and trenches, and the moisture contents of the recovered soil samples, the static groundwater is considered to have existed at a depth in excess of 25± feet at the time of the subsurface exploration.

Recent water level data was obtained from the California State Water Resources Control Board, GeoTracker, website, <https://geotracker.waterboards.ca.gov/>. The nearest monitoring well is located approximately 2150 feet southeast of the site. Water level readings within this monitoring well indicate high groundwater levels of 49± feet below the ground surface in June 2007.

## **Subsurface Exploration**

### Scope of Exploration

The subsurface exploration conducted for the infiltration testing consisted of seven (7) infiltration test borings, advanced to a depth of 12± feet below the existing site grades. The infiltration borings were advanced using a truck-mounted drilling rig, equipped with 8-inch-diameter hollow-stem augers and were logged during drilling by a member of our staff. The approximate locations of the infiltration test borings (identified as I-1 through I-7) are indicated on the Infiltration Test Location Plan, enclosed as Plate 2 of this report.

Upon the completion of the infiltration borings, the bottom of each test boring was covered with 2± inches of clean ¾-inch gravel. A sufficient length of 3-inch-diameter perforated PVC casing was then placed into each test hole so that the PVC casing extended from the bottom of the test hole to the ground surface. Clean ¾-inch gravel was then installed in the annulus surrounding the PVC casing.

## **Geotechnical Conditions**

Asphaltic concrete, 3± inches in thickness, was encountered at the ground surface at Infiltration Boring No. I-2. Native alluvial soils were encountered beneath the pavements or at the ground surface at all of the boring locations, extending to at least the maximum depth explored of 12± feet. The alluvium generally consists of loose to medium dense silty fine sands and silty fine to medium sands. Occasional layers of loose to medium dense fine to medium sands and fine sandy silts to silty fine sands, were encountered. The Boring Logs, which illustrate the conditions encountered at the boring locations, are included with this report.

## **Infiltration Testing**

As previously mentioned, the infiltration testing was performed in general accordance with the guidelines published in Riverside County – Low Impact Development BMP Design Handbook – Section 2.3 of Appendix A, which apply to San Bernardino County.

## Pre-soaking

In accordance with the county infiltration standards, all of the infiltration test borings were pre-soaked prior to the infiltration testing. The pre-soaking process consisted of filling the test borings by inverting a full 5-gallon bottle of clear water supported over each hole so that the water level reaches a level of at least 5 times the hole's radius above the gravel at the bottom of each hole. The pre-soaking was completed after all of the water had percolated through each test hole or after 15 hours since initiating the pre-soak.

## Infiltration Testing

Following the pre-soaking process of the infiltration test borings, SCG performed the infiltration testing. Each test hole was filled with water to a depth of at least 5 times the hole's radius above the gravel at the bottom of each test hole, and less than or equal to the water level used during the pre-soaking process. In accordance with the San Bernardino County guidelines, since "non-sandy soils" were encountered at the bottom of some infiltration borings, readings were taken at 30-minute intervals for a total of 6 hours. At Infiltration Boring Nos. I-3 through I-6, since "sandy-soils" were encountered at the bottom of the borings, readings were taken at 10-minute intervals for a total of 1 hour. After each reading, the borings were refilled to the correct water level above the gravel at the bottom of each test hole. The water level readings are presented on the spreadsheets enclosed with this report. The infiltration rates for each of the timed intervals are also tabulated on the spreadsheets.

The infiltration rates from the test are tabulated in inches per hour. In accordance with the typically accepted practice, it is recommended that the most conservative reading from the latter part of the infiltration tests be used as the design infiltration rate. The rates are summarized below:

<b><u>Infiltration Test No.</u></b>	<b><u>Depth (feet)</u></b>	<b><u>Soil Description</u></b>	<b><u>Measured Infiltration Rate (inches/hour)</u></b>
I-1	12	Silty fine to medium Sand	0.2
I-2	12	Silty fine Sand, trace medium Sand	0.5
I-3	12	Silty fine to medium Sand, trace coarse Sand	3.5
I-4	12	Silty fine to medium Sand, trace coarse Sand	5.5
I-5	12	Silty fine to medium Sand, trace coarse Sand	2.0
I-6	12	Silty fine to medium Sand, little coarse Sand	6.0
I-7	12	Silty fine to medium Sand, trace coarse Sand, trace fine Gravel	0.1

## **Laboratory Testing**

### Moisture Content

The moisture contents for the recovered soil samples within the borings were determined in accordance with ASTM D-2216 and are expressed as a percentage of the dry weight. These test results are presented on the Boring Logs.

### Grain Size Analysis

The grain size distribution of selected soils collected from the base of each infiltration test boring have been determined using a range of wire mesh screens. These tests were performed in general accordance with ASTM D-422 and/or ASTM D-1140. The weight of the portion of the sample retained on each screen is recorded and the percentage finer or coarser of the total weight is calculated. The results of these tests are presented on Plates C-1 through C-7 of this report.

## **Design Recommendations**

Seven (7) infiltration tests were performed at the subject site. As noted above, the infiltration rates at these locations vary from 0.1 to 19.6 inches per hour. The major factor affecting the difference in infiltration rates at the infiltration test locations is the presence of silt in the soils at the tested depths. Based on the infiltration test results, we recommend the following rates be used in the design of the infiltration systems:

<b>Infiltration System</b>	<b>Location</b>	<b>Design Infiltration Rate (Inches per Hour)</b>
"A"	North	Not Recommended
"B"	Central-North	0.3*
"C"	Central-South	4.5*
"D"	South	4.0*

\*Please note that an average infiltration rate was utilized for Infiltration Systems "B" through "D".

The design of the storm water infiltration system should be performed by the project civil engineer, in accordance with the City of Chino and/or San Bernadino guidelines. It is recommended that the system be constructed so as to facilitate removal of silt and clay, or other deleterious materials from any water that may enter the system. The presence of such materials would decrease the effective infiltration rates. **It is recommended that the project civil engineer apply an appropriate factor of safety. The infiltration rate recommended above is based on the assumption that only clean water will be introduced to the subsurface profile. Any fines, debris, or organic materials could significantly impact the infiltration rate.** It should be noted that the recommended infiltration rate is based on infiltration testing at seven (7) discrete locations and that the overall infiltration rate of the proposed infiltration system could vary considerably.

## **Infiltration Rate Considerations**

The infiltration rate presented herein was determined in accordance with the San Bernardino County guidelines and is considered valid only for the time and place of the actual test. Varying subsurface conditions will exist in other areas of the site, which could alter the recommended infiltration rate presented above. The infiltration rate will decline over time between maintenance cycles as silt or clay particles accumulate on the BMP surface. The infiltration rate is highly dependent upon a number of factors, including density, silt and clay content, grain size distribution throughout the range of particle sizes, and particle shape. Small changes in these factors can cause large changes in the infiltration rate.

Infiltration rates are based on unsaturated flow. As water is introduced into soils by infiltration, the soils become saturated and the wetting front advances from the unsaturated zone to the saturated zone. Once the soils become saturated, infiltration rates become zero, and water can only move through soils by hydraulic conductivity at a rate determined by pressure head and soil permeability. Changes in soil moisture content will affect the infiltration rate. Infiltration rates should be expected to decrease until the soils become saturated. Soil permeability values will then govern groundwater movement. Permeability values may be on the order of 10 to 20 times less than infiltration rates. The system designer should incorporate adequate factors of safety and allow for overflow design into appropriate traditional storm drain systems, which would transport storm water off-site.

## **Construction Considerations**

The infiltration rates presented in this report are specific to the tested locations and tested depths. Infiltration rates can be significantly reduced if the soils are exposed to excessive disturbance or compaction during construction. Compaction of the soils at the bottom of the infiltration system can significantly reduce the infiltration ability of the basins. Therefore, the subgrade soils within proposed infiltration system areas should not be over-excavated, undercut or compacted in any significant manner. **It is recommended that a note to this effect be added to the project plans and/or specifications.**

We recommend that a representative from the geotechnical engineer be on-site during the construction of the proposed infiltration system to identify the soil classification at the base of the system. It should be confirmed that the soils at the base of the proposed infiltration system correspond with those presented in this report to ensure that the performance of the system will be consistent with the rate reported herein.

We recommend that scrapers and other rubber-tired heavy equipment not be operated on the basin bottom, or at levels lower than 2 feet above the bottom of the system, particularly within basins. As such, the bottom 24 inches of the infiltration system should be excavated with non-rubber-tired equipment, such as excavators.

## **Chamber Maintenance**

The proposed project will include infiltration chambers. Water flowing into these chambers will carry some level of sediment. This layer has the potential to significantly reduce the infiltration rate of the chamber subgrade soils. Therefore, a formal chamber maintenance program should

be established to ensure that these silt and clay deposits are removed from the chamber on a regular basis.

### **Location of Infiltration Systems**

The use of on-site storm water infiltration systems carries a risk of creating adverse geotechnical conditions. Increasing the moisture content of the soil can cause the soil to lose internal shear strength and increase its compressibility, resulting in a change in the designed engineering properties. Overlying structures and pavements in the infiltration area could potentially be damaged due to saturation of the subgrade soils. **The proposed infiltration system for this site should be located at least 25 feet away from any structures, including retaining walls.** Even with this provision of locating the infiltration system at least 25 feet from the building(s), it is possible that infiltrating water into the subsurface soils could have an adverse effect on the proposed or existing structures. It should also be noted that utility trenches which happen to collect storm water can also serve as conduits to transmit storm water toward the structure, depending on the slope of the utility trench. Therefore, consideration should also be given to the proposed locations of underground utilities which may pass near the proposed infiltration system.

The infiltration system designer should also give special consideration to the effect that the proposed infiltration system may have on nearby subterranean structures, open excavations, or descending slopes. In particular, infiltration systems should not be located near the crest of descending slopes, particularly where the slopes are comprised of granular soils. Such systems will require specialized design and analysis to evaluate the potential for slope instability, piping failures and other phenomena that typically apply to earthen dam design. This type of analysis is beyond the scope of this infiltration test report, but these factors should be considered by the infiltration system designer when locating the infiltration systems.

### **General Comments**

This report has been prepared as an instrument of service for use by the client in order to aid in the evaluation of this property and to assist the architects and engineers in the design and preparation of the project plans and specifications. This report may be provided to the contractor(s) and other design consultants to disclose information relative to the project. However, this report is not intended to be utilized as a specification in and of itself, without appropriate interpretation by the project architect, structural engineer, and/or civil engineer. The design of the proposed storm water infiltration system is the responsibility of the civil engineer. The role of the geotechnical engineer is limited to determination of infiltration rate only. By using the design infiltration rate contained herein, the civil engineer agrees to indemnify, defend, and hold harmless the geotechnical engineer for all aspects of the design and performance of the proposed storm water infiltration system. The reproduction and distribution of this report must be authorized by the client and Southern California Geotechnical, Inc. Furthermore, any reliance on this report by an unauthorized third party is at such party's sole risk, and we accept no responsibility for damage or loss which may occur.

The analysis of this site was based on a subsurface profile interpolated from limited discrete soil samples. While the materials encountered in the project area are considered to be representative of the total area, some variations should be expected between boring locations and testing

depths. If the conditions encountered during construction vary significantly from those detailed herein, we should be contacted immediately to determine if the conditions alter the recommendations contained herein.

This report has been based on assumed or provided characteristics of the proposed development. It is recommended that the owner, client, architect, structural engineer, and civil engineer carefully review these assumptions to ensure that they are consistent with the characteristics of the proposed development. If discrepancies exist, they should be brought to our attention to verify that they do not affect the conclusions and recommendations contained herein. We also recommend that the project plans and specifications be submitted to our office for review to verify that our recommendations have been correctly interpreted. The analysis, conclusions, and recommendations contained within this report have been promulgated in accordance with generally accepted professional geotechnical engineering practice. No other warranty is implied or expressed.

### **Closure**

We sincerely appreciate the opportunity to be of service on this project. We look forward to providing additional consulting services during the course of the project. If we may be of further assistance in any manner, please contact our office.

Respectfully Submitted,

SOUTHERN CALIFORNIA GEOTECHNICAL, INC.



Ryan Bremer  
Staff Geologist



Robert G. Trazo, GE 2655  
Principal Engineer



Distribution: (1) Addressee

Enclosures: Plate 1 - Site Location Map  
Plate 2 - Infiltration Test Location Plan  
Boring Log Legend and Logs (9 pages)  
Infiltration Test Results Spreadsheets (7 pages)  
Grain Size Distribution Graphs (7 pages)

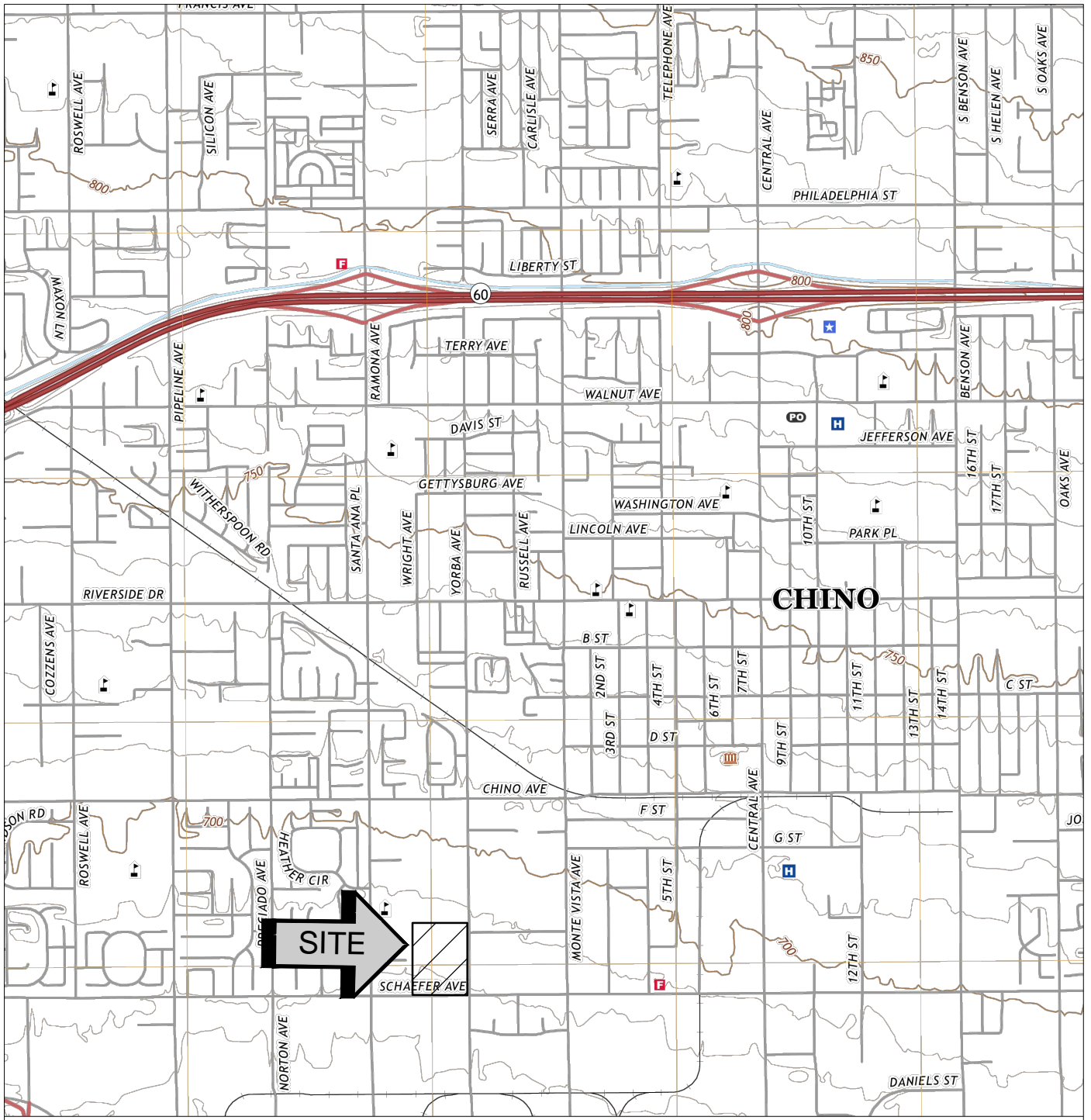

SOURCE: USGS TOPOGRAPHIC MAP OF THE ONTARIO QUADRANGLE, SAN BERNARDINO COUNTY, CALIFORNIA, 2021.



<b>SITE LOCATION MAP</b>	
PROPOSED INDUSTRIAL DEVELOPMENT	
CHINO, CALIFORNIA	
SCALE: 1" = 2000'	 <b>SOUTHERN CALIFORNIA GEOTECHNICAL</b>
DRAWN: AG	
CHKD: RGT	
SCG PROJECT 23G101-2	
<b>PLATE 1</b>	

YORBA AVENUE

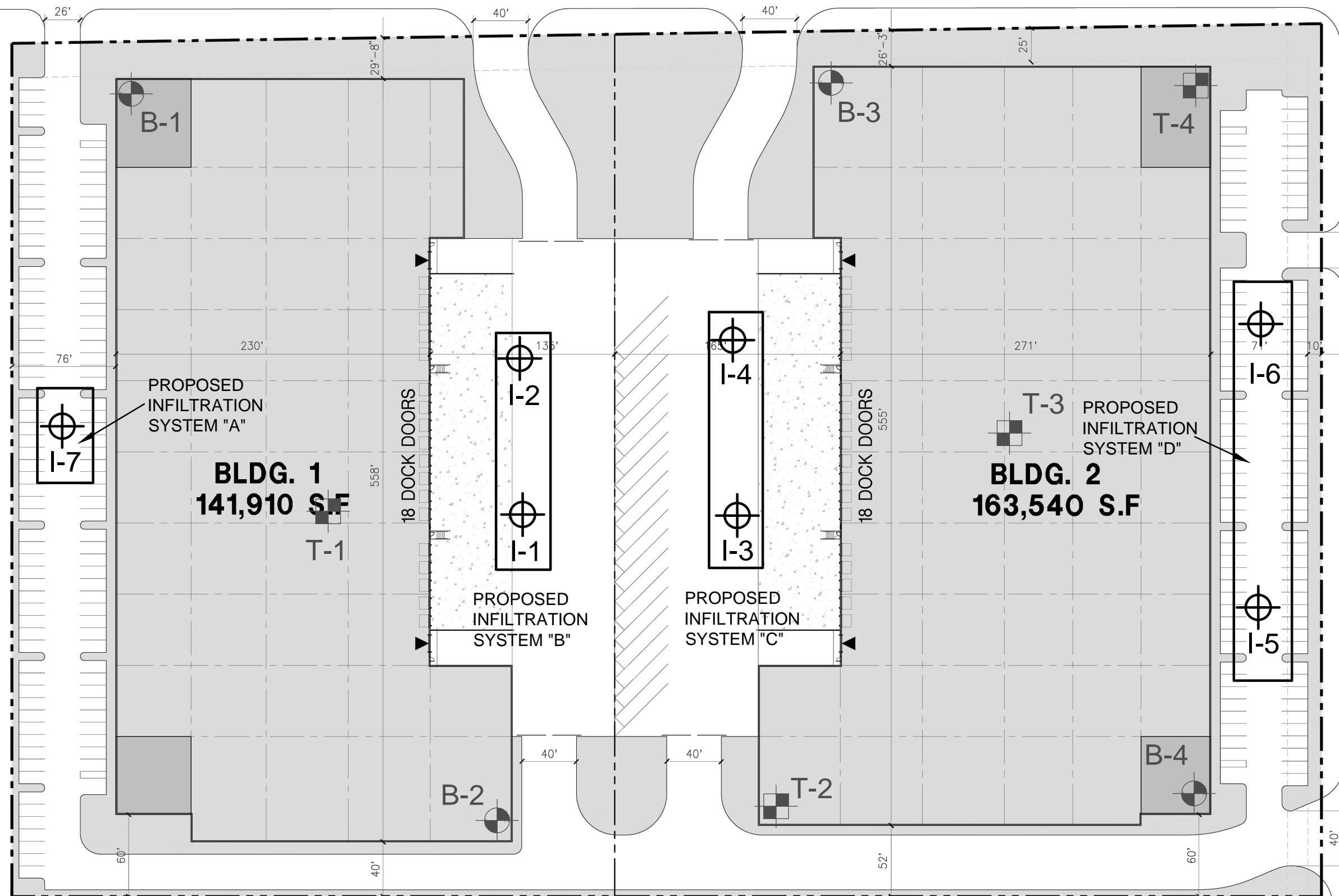







**GEOTECHNICAL LEGEND**

- APPROXIMATE INFILTRATION TEST LOCATION
- APPROXIMATE BORING LOCATION (SCG PROJECT NO. 23G101-1)
- APPROXIMATE TRENCH LOCATION (SCG PROJECT NO. 23G101-1)

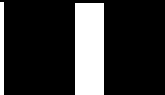
NOTE: SITE PLAN PREPARED BY HPA ARCHITECTURE.

<b>INFILTRATION TEST LOCATION PLAN</b>	
PROPOSED INDUSTRIAL DEVELOPMENT	
CHINO, CALIFORNIA	
SCALE: 1" = 80'	<b>SOUTHERN CALIFORNIA GEOTECHNICAL</b>
DRAWN: JAH	
CHKD: RGT	
SCG PROJECT 23G101-2	
<b>PLATE 2</b>	

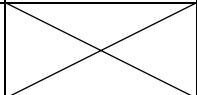
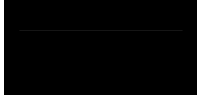
# BORING LOG LEGEND

SAMPLE TYPE	GRAPHICAL SYMBOL	SAMPLE DESCRIPTION
AUGER		SAMPLE COLLECTED FROM AUGER CUTTINGS, NO FIELD MEASUREMENT OF SOIL STRENGTH. (DISTURBED)
CORE		ROCK CORE SAMPLE: TYPICALLY TAKEN WITH A DIAMOND-TIPPED CORE BARREL. TYPICALLY USED ONLY IN HIGHLY CONSOLIDATED BEDROCK.
GRAB		SOIL SAMPLE TAKEN WITH NO SPECIALIZED EQUIPMENT, SUCH AS FROM A STOCKPILE OR THE GROUND SURFACE. (DISTURBED)
CS		CALIFORNIA SAMPLER: 2-1/2 INCH I.D. SPLIT BARREL SAMPLER, LINED WITH 1-INCH HIGH BRASS RINGS. DRIVEN WITH SPT HAMMER. (RELATIVELY UNDISTURBED)
NSR		NO RECOVERY: THE SAMPLING ATTEMPT DID NOT RESULT IN RECOVERY OF ANY SIGNIFICANT SOIL OR ROCK MATERIAL.
SPT		STANDARD PENETRATION TEST: SAMPLER IS A 1.4 INCH INSIDE DIAMETER SPLIT BARREL, DRIVEN 18 INCHES WITH THE SPT HAMMER. (DISTURBED)
SH		SHELBY TUBE: TAKEN WITH A THIN WALL SAMPLE TUBE, PUSHED INTO THE SOIL AND THEN EXTRACTED. (UNDISTURBED)
VANE		VANE SHEAR TEST: SOIL STRENGTH OBTAINED USING A 4 BLADED SHEAR DEVICE. TYPICALLY USED IN SOFT CLAYS-NO SAMPLE RECOVERED.

## COLUMN DESCRIPTIONS

### DEPTH:

Distance in feet below the ground surface.

### SAMPLE:

Sample Type as depicted above.

### BLOW COUNT:

Number of blows required to advance the sampler 12 inches using a 140 lb hammer with a 30-inch drop. 50/3" indicates penetration refusal (>50 blows) at 3 inches. WH indicates that the weight of the hammer was sufficient to push the sampler 6 inches or more.

### POCKET PEN.:

Approximate shear strength of a cohesive soil sample as measured by pocket penetrometer.

### GRAPHIC LOG:

Graphic Soil Symbol as depicted on the following page.

### DRY DENSITY:

Dry density of an undisturbed or relatively undisturbed sample in lbs/ft<sup>3</sup>.

### MOISTURE CONTENT:

Moisture content of a soil sample, expressed as a percentage of the dry weight.

### LIQUID LIMIT:

The moisture content above which a soil behaves as a liquid.

### PLASTIC LIMIT:

The moisture content above which a soil behaves as a plastic.

### PASSING #200 SIEVE:

The percentage of the sample finer than the #200 standard sieve.

### UNCONFINED SHEAR:

The shear strength of a cohesive soil sample, as measured in the unconfined state.

# SOIL CLASSIFICATION CHART

MAJOR DIVISIONS			SYMBOLS		TYPICAL DESCRIPTIONS	
			GRAPH	LETTER		
<p><b>COARSE GRAINED SOILS</b></p> <p>MORE THAN 50% OF MATERIAL IS LARGER THAN NO. 200 SIEVE SIZE</p>	<p><b>GRAVEL AND GRAVELLY SOILS</b></p>	<p>CLEAN GRAVELS</p> <p>(LITTLE OR NO FINES)</p>		<b>GW</b>	WELL-GRADED GRAVELS, GRAVEL - SAND MIXTURES, LITTLE OR NO FINES	
		<p>MORE THAN 50% OF COARSE FRACTION RETAINED ON NO. 4 SIEVE</p>	<p>GRAVELS WITH FINES</p> <p>(APPRECIABLE AMOUNT OF FINES)</p>		<b>GP</b>	POORLY-GRADED GRAVELS, GRAVEL - SAND MIXTURES, LITTLE OR NO FINES
			<p>GRAVELS WITH FINES</p> <p>(APPRECIABLE AMOUNT OF FINES)</p>		<b>GM</b>	SILTY GRAVELS, GRAVEL - SAND - SILT MIXTURES
		<p>MORE THAN 50% OF COARSE FRACTION PASSING ON NO. 4 SIEVE</p>	<p>CLEAN SANDS</p> <p>(LITTLE OR NO FINES)</p>		<b>SW</b>	WELL-GRADED SANDS, GRAVELLY SANDS, LITTLE OR NO FINES
	<p>MORE THAN 50% OF COARSE FRACTION PASSING ON NO. 4 SIEVE</p>		<p>SANDS WITH FINES</p> <p>(APPRECIABLE AMOUNT OF FINES)</p>		<b>SP</b>	POORLY-GRADED SANDS, GRAVELLY SAND, LITTLE OR NO FINES
		<p>SANDS WITH FINES</p> <p>(APPRECIABLE AMOUNT OF FINES)</p>		<b>SM</b>	SILTY SANDS, SAND - SILT MIXTURES	
	<p>SANDS WITH FINES</p> <p>(APPRECIABLE AMOUNT OF FINES)</p>		<b>SC</b>	CLAYEY SANDS, SAND - CLAY MIXTURES		
	<p><b>FINE GRAINED SOILS</b></p> <p>MORE THAN 50% OF MATERIAL IS SMALLER THAN NO. 200 SIEVE SIZE</p>	<p><b>SILTS AND CLAYS</b></p> <p>LIQUID LIMIT LESS THAN 50</p>		<b>ML</b>	INORGANIC SILTS AND VERY FINE SANDS, ROCK FLOUR, SILTY OR CLAYEY FINE SANDS OR CLAYEY SILTS WITH SLIGHT PLASTICITY	
				<b>CL</b>	INORGANIC CLAYS OF LOW TO MEDIUM PLASTICITY, GRAVELLY CLAYS, SANDY CLAYS, SILTY CLAYS, LEAN CLAYS	
				<b>OL</b>	ORGANIC SILTS AND ORGANIC SILTY CLAYS OF LOW PLASTICITY	
<p><b>SILTS AND CLAYS</b></p> <p>LIQUID LIMIT GREATER THAN 50</p>			<b>MH</b>	INORGANIC SILTS, MICACEOUS OR DIATOMACEOUS FINE SAND OR SILTY SOILS		
			<b>CH</b>	INORGANIC CLAYS OF HIGH PLASTICITY		
			<b>OH</b>	ORGANIC CLAYS OF MEDIUM TO HIGH PLASTICITY, ORGANIC SILTS		
<p><b>HIGHLY ORGANIC SOILS</b></p>				<b>PT</b>	PEAT, HUMUS, SWAMP SOILS WITH HIGH ORGANIC CONTENTS	

NOTE: DUAL SYMBOLS ARE USED TO INDICATE BORDERLINE SOIL CLASSIFICATIONS



JOB NO.: 23G101-2	DRILLING DATE: 1/23/23	WATER DEPTH: ---
PROJECT: Proposed Industrial Development	DRILLING METHOD: Hollow Stem Auger	CAVE DEPTH: Not Applicable
LOCATION: Chino, California	LOGGED BY: Joey Hernandez	READING TAKEN: At Completion

FIELD RESULTS				DESCRIPTION	LABORATORY RESULTS						COMMENTS
DEPTH (FEET)	SAMPLE	BLOW COUNT	POCKET PEN. (TSF)		GRAPHIC LOG	DRY DENSITY (PCF)	MOISTURE CONTENT (%)	LIQUID LIMIT	PLASTIC LIMIT	PASSING #200 SIEVE (%)	
SURFACE ELEVATION: --- MSL											
5					ALLUVIUM: Brown Silty fine Sand, trace medium Sand, medium dense-moist to very moist						
10	X	10					18				
10	X	12			Dark Brown Silty fine to medium Sand, medium dense-moist		12		36		
					Boring Terminated at 12 feet						

TBL\_23G101-2.GPJ\_SOCALGEO.GDT\_2/27/23





JOB NO.: 23G101-2	DRILLING DATE: 1/23/23	WATER DEPTH: ---
PROJECT: Proposed Industrial Development	DRILLING METHOD: Hollow Stem Auger	CAVE DEPTH: Not Applicable
LOCATION: Chino, California	LOGGED BY: Joey Hernandez	READING TAKEN: At Completion

FIELD RESULTS				GRAPHIC LOG	DESCRIPTION	LABORATORY RESULTS						COMMENTS
DEPTH (FEET)	SAMPLE	BLOW COUNT	POCKET PEN. (TSF)			DRY DENSITY (PCF)	MOISTURE CONTENT (%)	LIQUID LIMIT	PLASTIC LIMIT	PASSING #200 SIEVE (%)	ORGANIC CONTENT (%)	
SURFACE ELEVATION: --- MSL												
					3± inches Asphaltic concrete; No Discernible Aggregate Base <u>ALLUVIUM</u> : Brown Silty fine Sand, medium dense-very moist							
5												
10	X	18										
	X	6			Dark Gray Brown Silty fine Sand, trace medium Sand, loose-moist to very moist		16					
									19		39	
					Boring Terminated at 12 feet							

TBL\_23G101-2.GPJ\_SOCALGEO.GDT\_2/27/23



JOB NO.: 23G101-2	DRILLING DATE: 1/24/23	WATER DEPTH: ---
PROJECT: Proposed Industrial Development	DRILLING METHOD: Hollow Stem Auger	CAVE DEPTH: Not Applicable
LOCATION: Chino, California	LOGGED BY: Joey Hernandez	READING TAKEN: At Completion

FIELD RESULTS				GRAPHIC LOG	DESCRIPTION	LABORATORY RESULTS						COMMENTS
DEPTH (FEET)	SAMPLE	BLOW COUNT	POCKET PEN. (TSF)			DRY DENSITY (PCF)	MOISTURE CONTENT (%)	LIQUID LIMIT	PLASTIC LIMIT	PASSING #200 SIEVE (%)	ORGANIC CONTENT (%)	
SURFACE ELEVATION: --- MSL												
5					ALLUVIUM: Brown Silty fine Sand, trace medium Sand, medium dense-damp to moist							
10	X	15							9			
	X	12			Dark Gray Silty fine to medium Sand, trace coarse Sand, medium dense-damp				8	23		
					Boring Terminated at 12 feet							

TBL\_23G101-2.GPJ\_SOCALGEO.GDT\_2/27/23



JOB NO.: 23G101-2	DRILLING DATE: 1/23/23	WATER DEPTH: ---
PROJECT: Proposed Industrial Development	DRILLING METHOD: Hollow Stem Auger	CAVE DEPTH: Not Applicable
LOCATION: Chino, California	LOGGED BY: Joey Hernandez	READING TAKEN: At Completion

FIELD RESULTS				DESCRIPTION	LABORATORY RESULTS						COMMENTS
DEPTH (FEET)	SAMPLE	BLOW COUNT	POCKET PEN. (TSF)		GRAPHIC LOG	DRY DENSITY (PCF)	MOISTURE CONTENT (%)	LIQUID LIMIT	PLASTIC LIMIT	PASSING #200 SIEVE (%)	
SURFACE ELEVATION: --- MSL											
5					ALLUVIUM: Brown Silty fine Sand, trace medium Sand, loose-very moist		19				
10	X	6									
15	X	15			Dark Gray Brown Silty fine to medium Sand, trace coarse Sand, medium dense-damp to moist		9		21		
					Boring Terminated at 12 feet						

TBL\_23G101-2.GPJ\_SOCALGEO.GDT\_2/27/23



JOB NO.: 23G101-2	DRILLING DATE: 1/24/23	WATER DEPTH: ---
PROJECT: Proposed Industrial Development	DRILLING METHOD: Hollow Stem Auger	CAVE DEPTH: Not Applicable
LOCATION: Chino, California	LOGGED BY: Joey Hernandez	READING TAKEN: At Completion

FIELD RESULTS				DESCRIPTION	LABORATORY RESULTS						COMMENTS
DEPTH (FEET)	SAMPLE	BLOW COUNT	POCKET PEN. (TSF)		GRAPHIC LOG	DRY DENSITY (PCF)	MOISTURE CONTENT (%)	LIQUID LIMIT	PLASTIC LIMIT	PASSING #200 SIEVE (%)	
SURFACE ELEVATION: --- MSL											
5					<u>ALLUVIUM</u> : Dark Gray Brown Silty fine to medium Sand, trace coarse Sand, loose to medium dense-moist to very moist						
10	X X	9 16					18			23	
					Boring Terminated at 12 feet						

TBL\_23G101-2.GPJ\_SOCALGEO.GDT\_2/27/23



JOB NO.: 23G101-2	DRILLING DATE: 1/23/23	WATER DEPTH: ---
PROJECT: Proposed Industrial Development	DRILLING METHOD: Hollow Stem Auger	CAVE DEPTH: Not Applicable
LOCATION: Chino, California	LOGGED BY: Joey Hernandez	READING TAKEN: At Completion

FIELD RESULTS				GRAPHIC LOG	DESCRIPTION	LABORATORY RESULTS						COMMENTS
DEPTH (FEET)	SAMPLE	BLOW COUNT	POCKET PEN. (TSF)			DRY DENSITY (PCF)	MOISTURE CONTENT (%)	LIQUID LIMIT	PLASTIC LIMIT	PASSING #200 SIEVE (%)	ORGANIC CONTENT (%)	
SURFACE ELEVATION: --- MSL												
5					ALLUVIUM: Brown Silty fine Sand, medium dense-moist							
10	16 20				Dark Brown Silty fine to medium Sand, little coarse Sand, medium dense-damp	13				4	13	
Boring Terminated at 12 feet												

TBL\_23G101-2.GPJ\_SOCALGEO.GDT\_2/27/23



JOB NO.: 23G101-2	DRILLING DATE: 1/23/23	WATER DEPTH: ---
PROJECT: Proposed Industrial Development	DRILLING METHOD: Hollow Stem Auger	CAVE DEPTH: Not Applicable
LOCATION: Chino, California	LOGGED BY: Joey Hernandez	READING TAKEN: At Completion

FIELD RESULTS				GRAPHIC LOG	DESCRIPTION	LABORATORY RESULTS						COMMENTS
DEPTH (FEET)	SAMPLE	BLOW COUNT	POCKET PEN. (TSF)			DRY DENSITY (PCF)	MOISTURE CONTENT (%)	LIQUID LIMIT	PLASTIC LIMIT	PASSING #200 SIEVE (%)	ORGANIC CONTENT (%)	
SURFACE ELEVATION: --- MSL												
5					<u>ALLUVIUM</u> : Gray Brown fine Sandy Silt to fine Sandy Silt, medium dense-very moist							
10		11				28						
		9			Dark Brown Silty fine to medium Sand, trace coarse Sand, trace fine Gravel, loose-moist	16			33			
					Boring Terminated at 12 feet							

TBL\_23G101-2.GPJ\_SOCALGEO.GDT\_2/27/23

# INFILTRATION CALCULATIONS

Project Name	Proposed Industrial Development
Project Location	Chino, California
Project Number	23G101-2
Engineer	RB

Test Hole Radius	4 (in)
Test Depth	12.00 (ft)

Infiltration Test Hole	I-1
------------------------	-----

Soil Criteria Test							
Interval Number		Time	Time Interval (min)	Water Depth (ft)	Change in Water Level (in)	Did 6 inches of water seep away in less than 25 minutes?	Sandy Soils or Non-Sandy Soils?
1	Initial	12:20 PM	25.00	9.70	-0.12	NO	NON-SANDY SOILS
	Final	12:45 PM		9.69			
2	Initial	12:45 PM	25.00	9.78	2.04	NO	NON-SANDY SOILS
	Final	1:10 PM		9.95			

Test Data							
Interval Number		Time	Time Interval (min)	Water Depth (ft)	Change in Water Level (ft)	Average Head Height (ft)	Infiltration Rate Q (in/hr)
1	Initial	11:10 AM	30.00	9.90	0.16	2.02	0.29
	Final	11:40 AM		10.06			
2	Initial	11:40 AM	30.00	10.06	0.14	1.87	0.27
	Final	12:10 PM		10.20			
3	Initial	12:10 PM	30.00	9.87	0.14	2.06	0.25
	Final	12:40 PM		10.01			
4	Initial	12:40 PM	30.00	10.00	0.13	1.94	0.25
	Final	1:10 PM		10.13			
5	Initial	1:10 PM	30.00	10.04	0.13	1.90	0.25
	Final	1:40 PM		10.17			
6	Initial	1:40 PM	30.00	10.01	0.13	1.93	0.25
	Final	2:10 PM		10.14			
7	Initial	2:10 PM	30.00	10.00	0.12	1.94	0.23
	Final	2:40 PM		10.12			
8	Initial	2:40 PM	30.00	10.12	0.10	1.83	0.20
	Final	3:10 PM		10.22			
9	Initial	3:10 PM	30.00	10.04	0.11	1.91	0.21
	Final	3:40 PM		10.15			
10	Initial	3:40 PM	30.00	10.02	0.10	1.93	0.19
	Final	4:10 PM		10.12			
11	Initial	4:40 PM	30.00	10.00	0.10	1.95	0.19
	Final	5:10 PM		10.10			
12	Initial	5:10 PM	30.00	9.98	0.10	1.97	0.19
	Final	5:40 PM		10.08			

Per County Standards, Infiltration Rate calculated as follows:

$$Q = \frac{\Delta H(60r)}{\Delta t(r + 2H_{avg})}$$

Where:

- Q = Infiltration Rate (in inches per hour)
- ΔH = Change in Height (Water Level) over the time interval
- r = Test Hole (Borehole) Radius
- Δt = Time Interval
- H<sub>avg</sub> = Average Head Height over the time interval

# INFILTRATION CALCULATIONS

Project Name	Proposed Industrial Development
Project Location	Chino, California
Project Number	23G101-2
Engineer	RB

Test Hole Radius	4 (in)
Test Depth	12.10 (ft)

Infiltration Test Hole	I-2
------------------------	-----

Soil Criteria Test							
Interval Number		Time	Time Interval (min)	Water Depth (ft)	Change in Water Level (in)	Did 6 inches of water seep away in less than 25 minutes?	Sandy Soils or Non-Sandy Soils?
1	Initial	9:45 AM	25.00	9.90	-2.52	NO	NON-SANDY SOILS
	Final	10:10 AM		9.69			
2	Initial	10:10 AM	25.00	9.97	3.00	NO	NON-SANDY SOILS
	Final	10:35 AM		10.22			

Test Data							
Interval Number		Time	Time Interval (min)	Water Depth (ft)	Change in Water Level (ft)	Average Head Height (ft)	Infiltration Rate Q (in/hr)
1	Initial	10:35 AM	30.00	10.10	0.30	1.85	0.60
	Final	11:05 AM		10.40			
2	Initial	11:05 AM	30.00	10.13	0.28	1.83	0.56
	Final	11:35 AM		10.41			
3	Initial	11:35 AM	30.00	10.07	0.28	1.89	0.54
	Final	12:05 PM		10.35			
4	Initial	12:05 PM	30.00	10.04	0.29	1.92	0.56
	Final	12:35 PM		10.33			
5	Initial	12:35 PM	30.00	10.15	0.27	1.82	0.54
	Final	1:05 PM		10.42			
6	Initial	1:05 PM	30.00	10.15	0.26	1.82	0.52
	Final	1:35 PM		10.41			
7	Initial	1:35 PM	30.00	10.04	0.26	1.93	0.50
	Final	2:05 PM		10.30			
8	Initial	2:05 PM	30.00	10.00	0.28	1.96	0.53
	Final	2:35 PM		10.28			
9	Initial	2:35 PM	30.00	10.02	0.27	1.95	0.51
	Final	3:05 PM		10.29			
10	Initial	3:05 PM	30.00	9.98	0.27	1.99	0.50
	Final	3:35 PM		10.25			
11	Initial	3:35 PM	30.00	10.00	0.26	1.97	0.49
	Final	4:05 PM		10.26			
12	Initial	4:05 PM	30.00	10.05	0.25	1.93	0.48
	Final	4:35 PM		10.30			

Per County Standards, Infiltration Rate calculated as follows:

$$Q = \frac{\Delta H(60r)}{\Delta t(r + 2H_{avg})}$$

Where:

- Q = Infiltration Rate (in inches per hour)
- ΔH = Change in Height (Water Level) over the time interval
- r = Test Hole (Borehole) Radius
- Δt = Time Interval
- H<sub>avg</sub> = Average Head Height over the time interval

## INFILTRATION CALCULATIONS

Project Name	Proposed Industrial Development
Project Location	Chino, California
Project Number	23G101-2
Engineer	RB

Test Hole Radius	4 (in)
Test Depth	12.00 (ft)

Infiltration Test Hole	I-3
------------------------	-----

Soil Criteria Test							
Interval Number		Time	Time Interval (min)	Water Depth (ft)	Change in Water Level (in)	Did 6 inches of water seep away in less than 25 minutes?	Sandy Soils or Non-Sandy Soils?
1	Initial	9:41 AM	25.00	9.95	-3.12	NO	NON-SANDY SOILS
	Final	10:06 AM		9.69			
2	Initial	10:06 AM	25.00	9.98	22.56	YES	SANDY SOILS
	Final	10:31 AM		11.86			

Test Data							
Interval Number		Time	Time Interval (min)	Water Depth (ft)	Change in Water Level (ft)	Average Head Height (ft)	Infiltration Rate Q (in/hr)
1	Initial	10:31 AM	10.00	9.99	0.72	1.65	4.76
	Final	10:41 AM		10.71			
2	Initial	10:41 AM	10.00	10.01	0.58	1.70	3.73
	Final	10:51 AM		10.59			
3	Initial	10:51 AM	10.00	10.05	0.63	1.64	4.20
	Final	11:01 AM		10.68			
4	Initial	11:01 AM	10.00	10.05	0.56	1.67	3.66
	Final	11:11 AM		10.61			
5	Initial	11:11 AM	10.00	10.04	0.55	1.69	3.56
	Final	11:21 AM		10.59			
6	Initial	11:21 AM	10.00	10.06	0.53	1.68	3.45
	Final	11:31 AM		10.59			

Per County Standards, Infiltration Rate calculated as follows:

$$Q = \frac{\Delta H(60r)}{\Delta t(r + 2H_{avg})}$$

- Where:
- Q = Infiltration Rate (in inches per hour)
  - ΔH = Change in Height (Water Level) over the time interval
  - r = Test Hole (Borehole) Radius
  - Δt = Time Interval
  - H<sub>avg</sub> = Average Head Height over the time interval

## INFILTRATION CALCULATIONS

Project Name	Proposed Industrial Development
Project Location	Chino, California
Project Number	23G101-2
Engineer	RB

Test Hole Radius	4 (in)
Test Depth	12.00 (ft)

Infiltration Test Hole	I-4
------------------------	-----

Soil Criteria Test							
Interval Number		Time	Time Interval (min)	Water Depth (ft)	Change in Water Level (in)	Did 6 inches of water seep away in less than 25 minutes?	Sandy Soils or Non-Sandy Soils?
1	Initial	10:39 AM	25.00	9.70	-0.12	NO	NON-SANDY SOILS
	Final	11:04 AM		9.69			
2	Initial	11:04 AM	25.00	9.80	24.24	YES	SANDY SOILS
	Final	11:29 AM		11.82			

Test Data							
Interval Number		Time	Time Interval (min)	Water Depth (ft)	Change in Water Level (ft)	Average Head Height (ft)	Infiltration Rate Q (in/hr)
1	Initial	11:31 AM	10.00	9.97	0.83	1.62	5.59
	Final	11:41 AM		10.80			
2	Initial	11:41 AM	10.00	10.00	0.77	1.62	5.19
	Final	11:51 AM		10.77			
3	Initial	11:51 AM	10.00	10.00	0.92	1.54	6.47
	Final	12:01 PM		10.92			
4	Initial	12:01 PM	10.00	10.00	0.89	1.56	6.20
	Final	12:11 PM		10.89			
5	Initial	12:11 PM	10.00	10.01	0.83	1.58	5.72
	Final	12:21 PM		10.84			
6	Initial	12:21 PM	10.00	10.04	0.79	1.57	5.47
	Final	12:31 PM		10.83			

Per County Standards, Infiltration Rate calculated as follows:

$$Q = \frac{\Delta H(60r)}{\Delta t(r + 2H_{avg})}$$

- Where:
- Q = Infiltration Rate (in inches per hour)
  - ΔH = Change in Height (Water Level) over the time interval
  - r = Test Hole (Borehole) Radius
  - Δt = Time Interval
  - H<sub>avg</sub> = Average Head Height over the time interval

## INFILTRATION CALCULATIONS

Project Name	Proposed Industrial Development
Project Location	Chino, California
Project Number	23G101-2
Engineer	RB

Test Hole Radius	4 (in)
Test Depth	12.05 (ft)

Infiltration Test Hole	I-5
------------------------	-----

Soil Criteria Test							
Interval Number		Time	Time Interval (min)	Water Depth (ft)	Change in Water Level (in)	Did 6 inches of water seep away in less than 25 minutes?	Sandy Soils or Non-Sandy Soils?
1	Initial	10:24 AM	25.00	9.71	-0.24	NO	NON-SANDY SOILS
	Final	10:49 AM		9.69			
2	Initial	10:49 AM	25.00	9.80	15.84	YES	SANDY SOILS
	Final	11:14 AM		11.12			

Test Data							
Interval Number		Time	Time Interval (min)	Water Depth (ft)	Change in Water Level (ft)	Average Head Height (ft)	Infiltration Rate Q (in/hr)
1	Initial	11:14 AM	10.00	10.06	0.54	1.72	3.43
	Final	11:24 AM		10.60			
2	Initial	11:25 AM	10.00	9.80	0.55	1.98	3.08
	Final	11:35 AM		10.35			
3	Initial	11:36 AM	10.00	10.01	0.43	1.83	2.59
	Final	11:46 AM		10.44			
4	Initial	11:48 AM	10.00	10.02	0.37	1.85	2.21
	Final	11:58 AM		10.39			
5	Initial	12:00 PM	10.00	10.01	0.36	1.86	2.13
	Final	12:10 PM		10.37			
6	Initial	12:11 PM	10.00	9.80	0.37	2.07	1.99
	Final	12:21 PM		10.17			

Per County Standards, Infiltration Rate calculated as follows:

$$Q = \frac{\Delta H(60r)}{\Delta t(r + 2H_{avg})}$$

- Where:
- Q = Infiltration Rate (in inches per hour)
  - ΔH = Change in Height (Water Level) over the time interval
  - r = Test Hole (Borehole) Radius
  - Δt = Time Interval
  - H<sub>avg</sub> = Average Head Height over the time interval

## INFILTRATION CALCULATIONS

Project Name	Proposed Industrial Development
Project Location	Chino, California
Project Number	23G101-2
Engineer	RB

Test Hole Radius	4 (in)
Test Depth	12.00 (ft)

Infiltration Test Hole	I-6
------------------------	-----

Soil Criteria Test							
Interval Number		Time	Time Interval (min)	Water Depth (ft)	Change in Water Level (in)	Did 6 inches of water seep away in less than 25 minutes?	Sandy Soils or Non-Sandy Soils?
1	Initial	8:37 AM	25.00	9.70	-0.12	NO	NON-SANDY SOILS
	Final	9:02 AM		9.69			
2	Initial	9:02 AM	25.00	9.68	27.84	YES	SANDY SOILS
	Final	9:27 AM		12.00			

Test Data							
Interval Number		Time	Time Interval (min)	Water Depth (ft)	Change in Water Level (ft)	Average Head Height (ft)	Infiltration Rate Q (in/hr)
1	Initial	9:28 AM	10.00	10.00	1.14	1.43	8.57
	Final	9:38 AM		11.14			
2	Initial	9:38 AM	10.00	9.95	1.06	1.52	7.54
	Final	9:48 AM		11.01			
3	Initial	9:48 AM	10.00	9.95	0.99	1.56	6.90
	Final	9:58 AM		10.94			
4	Initial	9:58 AM	10.00	9.79	1.00	1.71	6.39
	Final	10:08 AM		10.79			
5	Initial	10:08 AM	10.00	9.85	0.94	1.68	6.11
	Final	10:18 AM		10.79			
6	Initial	10:18 AM	10.00	9.85	0.92	1.69	5.95
	Final	10:28 AM		10.77			

Per County Standards, Infiltration Rate calculated as follows:

$$Q = \frac{\Delta H(60r)}{\Delta t(r + 2H_{avg})}$$

- Where:
- Q = Infiltration Rate (in inches per hour)
  - ΔH = Change in Height (Water Level) over the time interval
  - r = Test Hole (Borehole) Radius
  - Δt = Time Interval
  - H<sub>avg</sub> = Average Head Height over the time interval

# INFILTRATION CALCULATIONS

Project Name	Proposed Industrial Development
Project Location	Chino, California
Project Number	23G101-2
Engineer	RB

Test Hole Radius	4 (in)
Test Depth	12.10 (ft)

Infiltration Test Hole	I-7
------------------------	-----

Soil Criteria Test							
Interval Number		Time	Time Interval (min)	Water Depth (ft)	Change in Water Level (in)	Did 6 inches of water seep away in less than 25 minutes?	Sandy Soils or Non-Sandy Soils?
1	Initial	8:52 AM	25.00	9.65	0.48	NO	NON-SANDY SOILS
	Final	9:17 AM		9.69			
2	Initial	9:17 AM	25.00	9.68	0.36	NO	NON-SANDY SOILS
	Final	9:42 AM		9.71			

Test Data							
Interval Number		Time	Time Interval (min)	Water Depth (ft)	Change in Water Level (ft)	Average Head Height (ft)	Infiltration Rate Q (in/hr)
1	Initial	9:42 AM	30.00	9.78	0.14	2.25	0.23
	Final	10:12 AM		9.92			
2	Initial	10:12 AM	30.00	9.79	0.13	2.25	0.22
	Final	10:42 AM		9.92			
3	Initial	10:42 AM	30.00	9.81	0.11	2.24	0.18
	Final	11:12 AM		9.92			
4	Initial	11:12 AM	30.00	9.82	0.08	2.24	0.13
	Final	11:42 AM		9.90			
5	Initial	11:42 AM	30.00	9.75	0.07	2.32	0.11
	Final	12:12 PM		9.82			
6	Initial	12:12 PM	30.00	9.78	0.07	2.29	0.11
	Final	12:42 PM		9.85			
7	Initial	12:42 PM	30.00	9.76	0.08	2.30	0.12
	Final	1:12 PM		9.84			
8	Initial	1:12 PM	30.00	9.74	0.08	2.32	0.12
	Final	1:42 PM		9.82			
9	Initial	1:42 PM	30.00	9.73	0.06	2.34	0.10
	Final	2:12 PM		9.79			
10	Initial	2:12 PM	30.00	9.71	0.07	2.36	0.12
	Final	2:42 PM		9.78			
11	Initial	2:42 PM	30.00	9.69	0.07	2.38	0.11
	Final	3:12 PM		9.76			
12	Initial	3:12 PM	30.00	9.71	0.07	2.36	0.11
	Final	3:42 PM		9.78			

Per County Standards, Infiltration Rate calculated as follows:

$$Q = \frac{\Delta H(60r)}{\Delta t(r + 2H_{avg})}$$

Where:

- Q = Infiltration Rate (in inches per hour)
- $\Delta H$  = Change in Height (Water Level) over the time interval
- r = Test Hole (Borehole) Radius
- $\Delta t$  = Time Interval
- $H_{avg}$  = Average Head Height over the time interval



# Grain Size Distribution

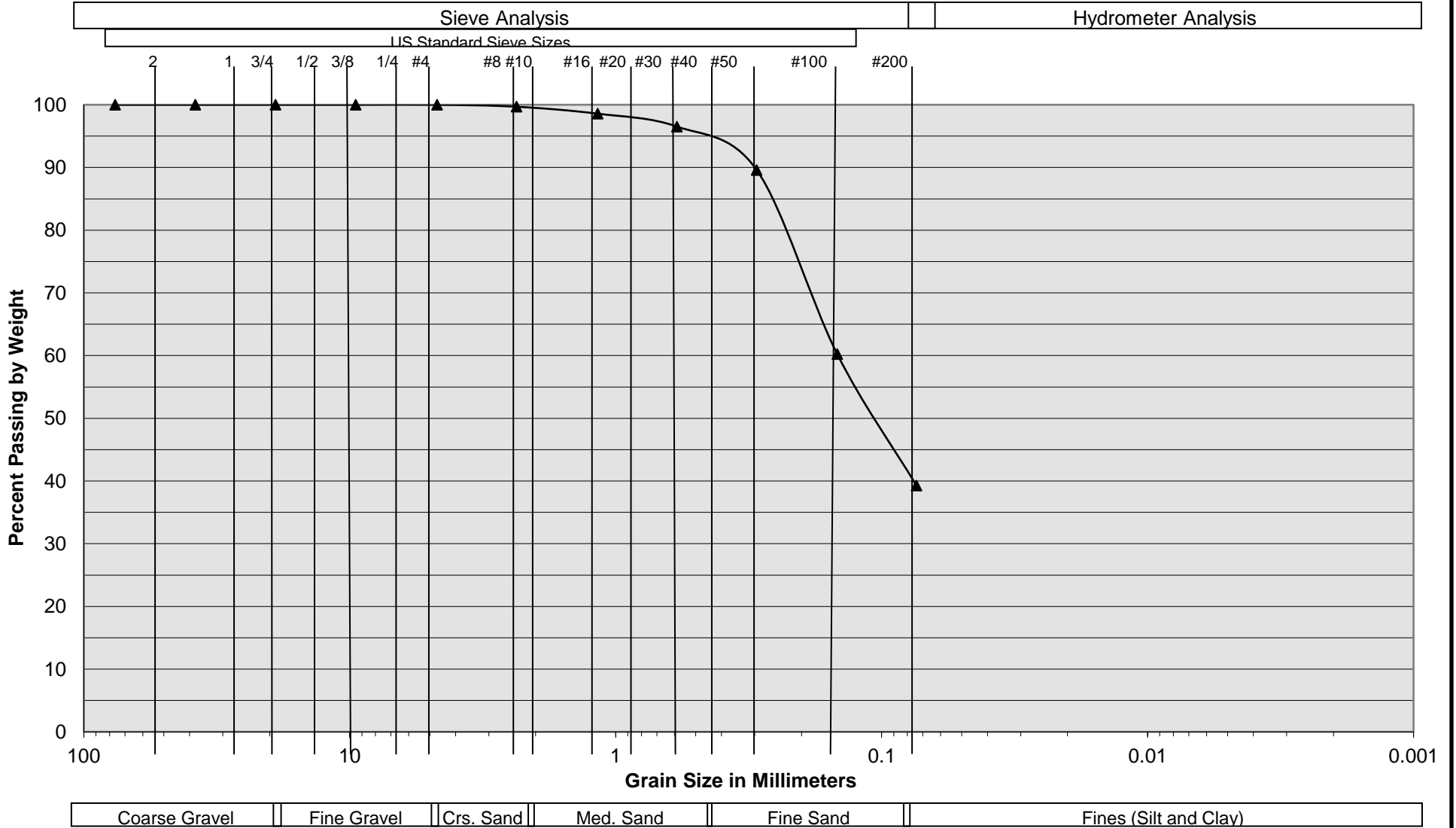

Sample Description	I-2 @ 10½ to 12 feet
Soil Classification	Silty fine Sand, trace medium Sand

Proposed Industrial Development  
 Chino, California  
 Project No. 23G101-2  
**PLATE C- 2**





**SOUTHERN CALIFORNIA GEOTECHNICAL**  
A California Corporation



# Grain Size Distribution

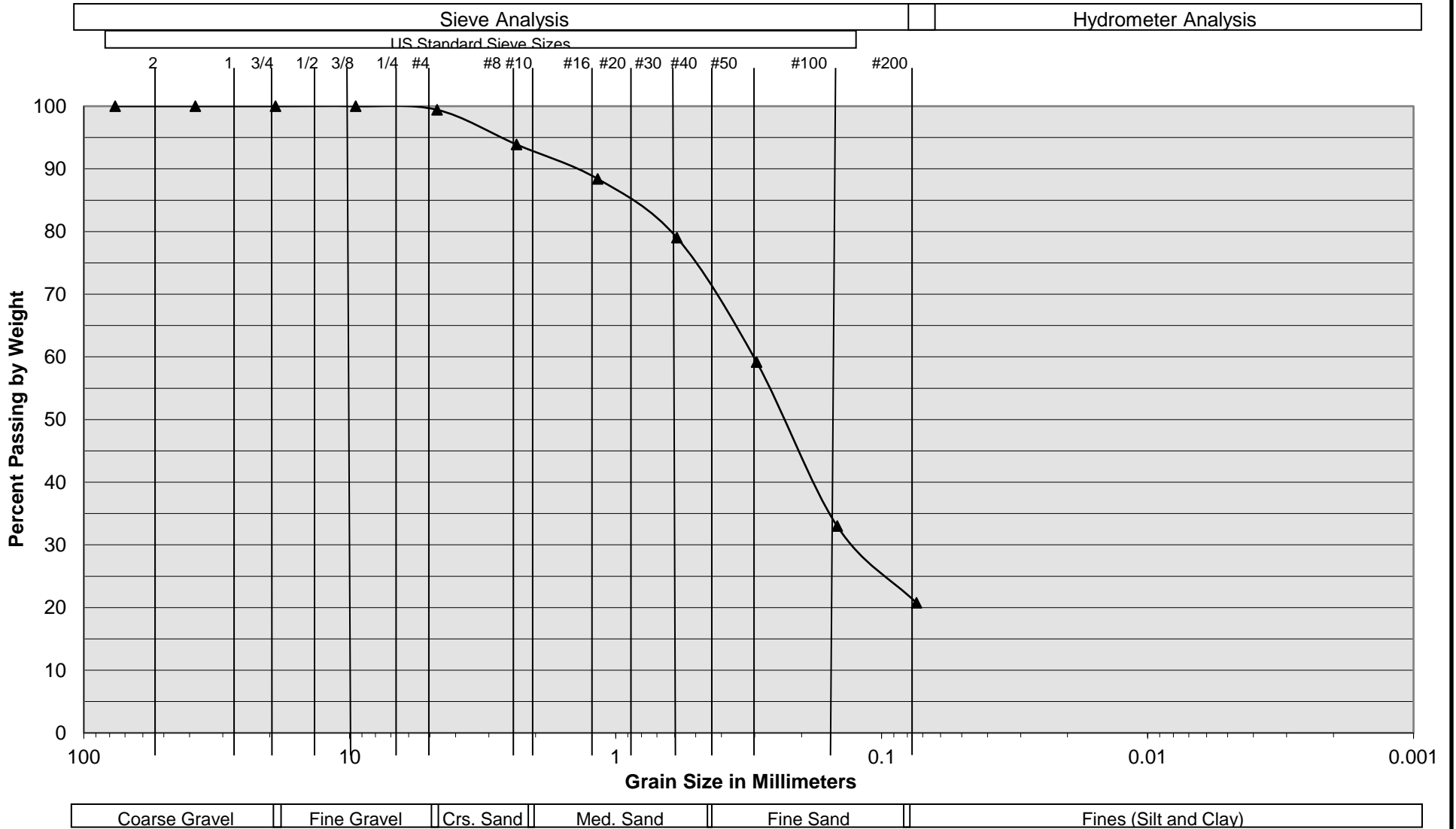

Sample Description	I-4 @ 10½ to 12 feet
Soil Classification	Silty fine to medium Sand, trace coarse Sand

Proposed Industrial Development  
 Chino, California  
 Project No. 23G101-2  
**PLATE C- 4**



# Grain Size Distribution

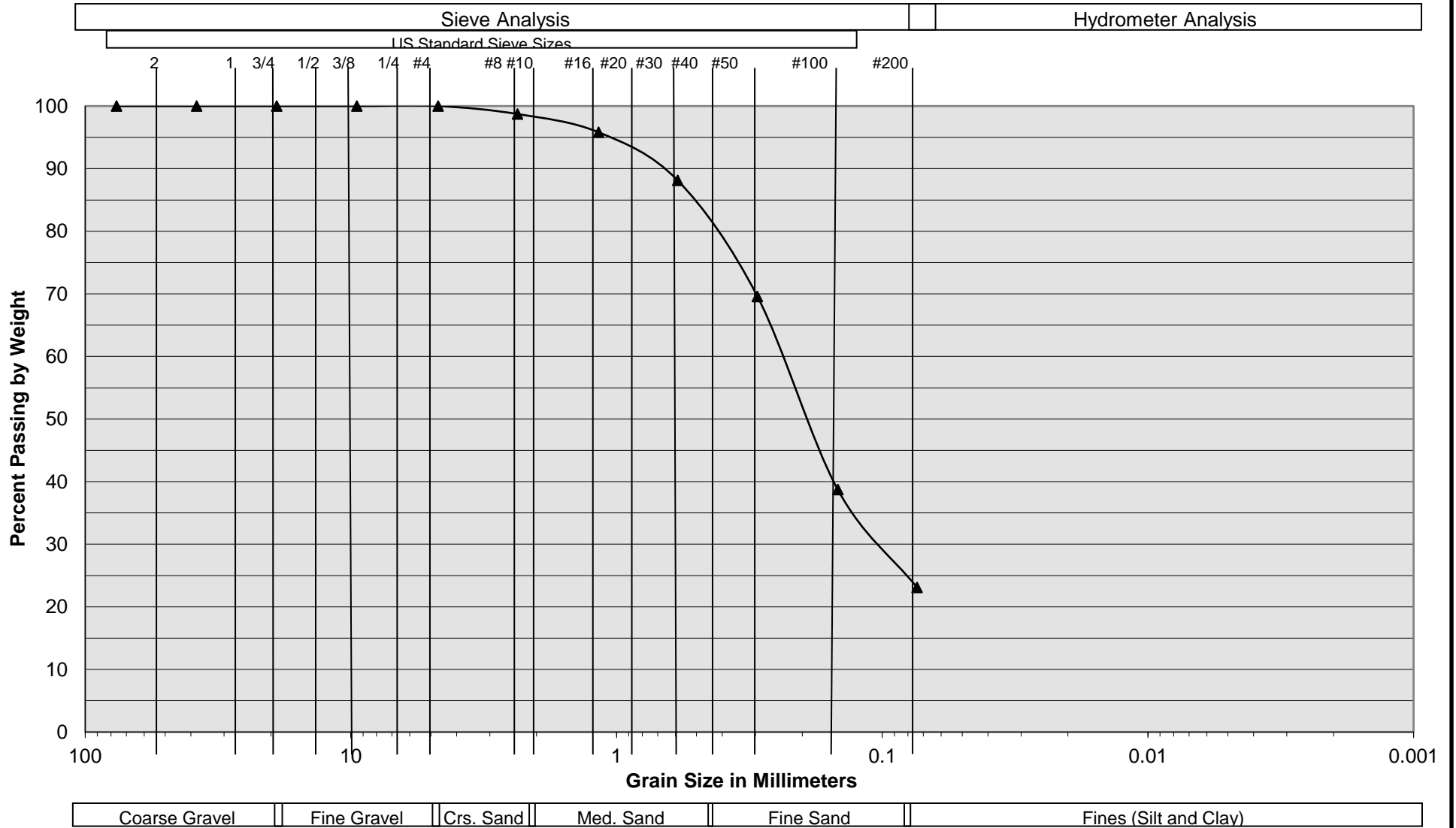

Sample Description	I-5 @ 10½ to 12 feet
Soil Classification	Silty fine to medium Sand, trace coarse Sand

Proposed Industrial Development  
 Chino, California  
 Project No. 23G101-2  
**PLATE C- 5**



**SOUTHERN CALIFORNIA GEOTECHNICAL**  
A California Corporation

# Grain Size Distribution

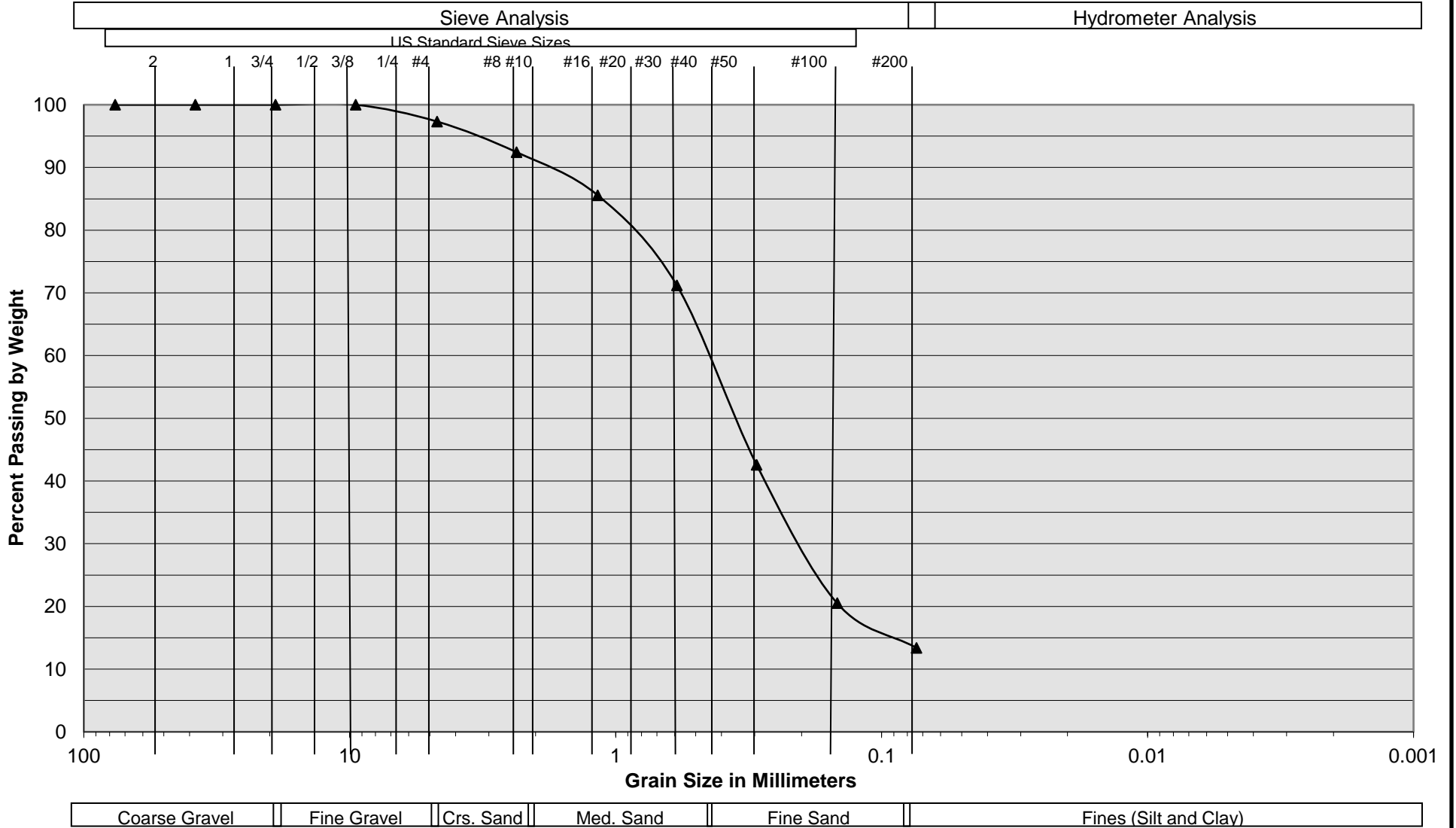

Sample Description	I-6 @ 10½ to 12 feet
Soil Classification	Silty fine to medium Sand, little coarse Sand

Proposed Industrial Development  
 Chino, California  
 Project No. 23G101-2  
**PLATE C- 6**





**SOUTHERN CALIFORNIA GEOTECHNICAL**  
A California Corporation

# Grain Size Distribution

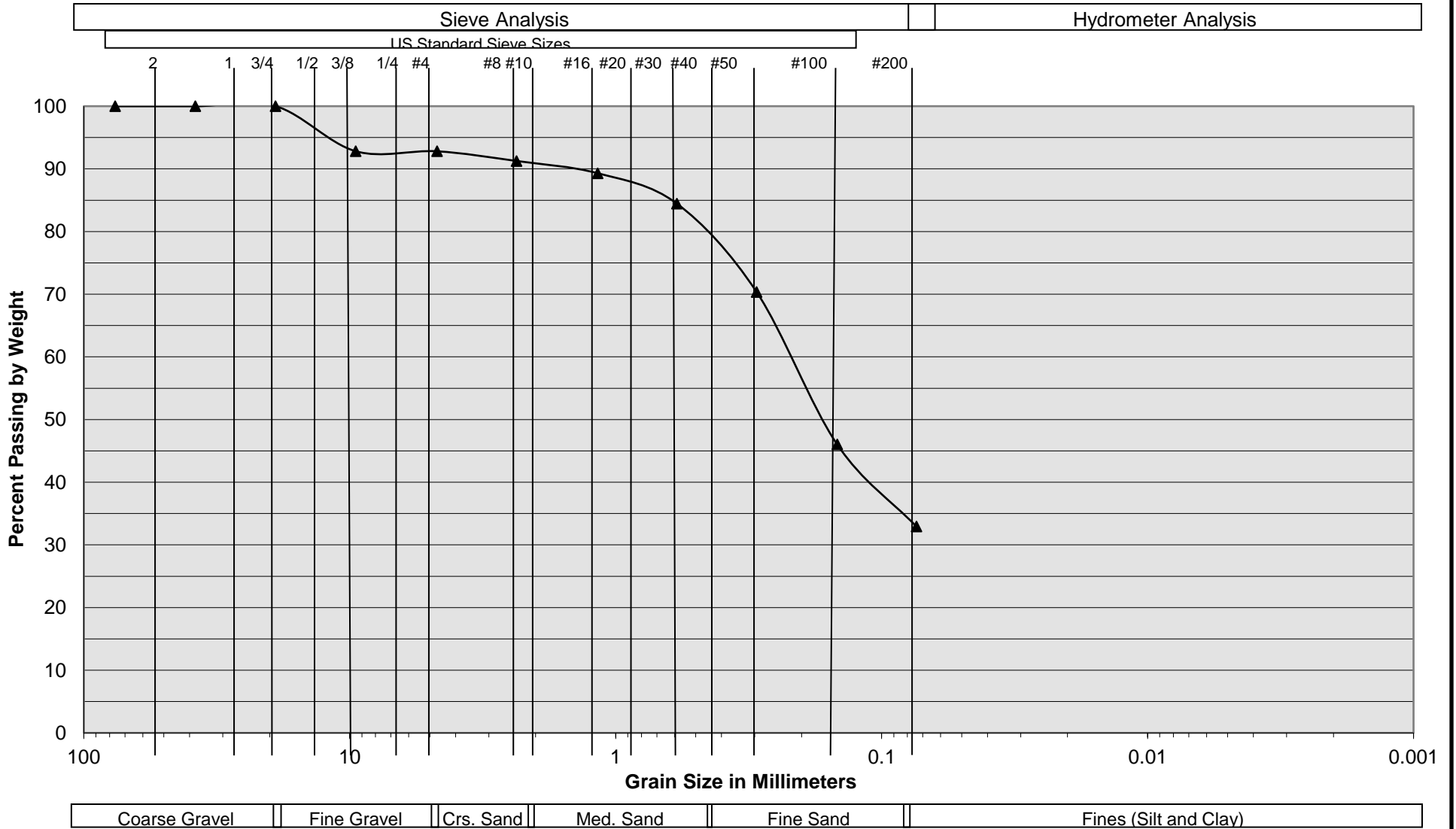

Sample Description	I-7 @ 10½ to 12 feet
Soil Classification	Silty fine to medium Sand, trace coarse Sand, trace fine Gravel

Proposed Industrial Development  
 Chino, California  
 Project No. 23G101-2  
**PLATE C-7**



**SOUTHERN CALIFORNIA GEOTECHNICAL**  
*A California Corporation*

# **Attachment G**

## **Hydrologic Conditions of Concern**

## Form 4.2-2 of HCOC Assessment

Does project have the potential to cause or contribute to an HCOC in a downstream channel: Yes No

Go to: <http://sbcounty.permitrack.com/WAP/>

If "Yes", then complete HCOC assessment of site hydrology for 2yr storm event using Forms 4.2-3 through 4.2-5 and insert results below (Forms 4.2-3 through 4.2-5 may be replaced by computer software analysis based on the San Bernardino County Hydrology Manual)

If "No," then proceed to Section 4.3 Project Conformance Analysis

Condition	Runoff Volume (ft <sup>3</sup> )	Time of Concentration (min)	Peak Runoff (cfs)
<b>Pre-developed</b>	<sup>1</sup> 39,525 <i>Form 4.2-3 Item 12</i>	<sup>2</sup> N/A <i>Form 4.2-4 Item 13</i>	<sup>3</sup> N/A <i>Form 4.2-5 Item 10</i>
<b>Post-developed</b>	<sup>4</sup> 109,736 <i>Form 4.2-3 Item 13</i>	<sup>5</sup> N/A <i>Form 4.2-4 Item 14</i>	<sup>6</sup> N/A <i>Form 4.2-5 Item 14</i>
<b>Difference</b>	<sup>7</sup> 70,211 <i>Item 4 – Item 1</i>	<sup>8</sup> N/A <i>Item 5 – Item 2</i>	<sup>9</sup> N/A <i>Item 6 – Item 3</i>
<b>Difference</b> (as % of pre-developed)	<sup>10</sup> 178% <i>Item 7 / Item 1</i>	<sup>11</sup> N/A <i>Item 8 / Item 2</i>	<sup>12</sup> N/A <i>Item 9 / Item 3</i>

To meet HCOC requirements, a mitigation volume must be achieved by using LID and/or hydromodification mitigation BMPs. The mitigation volume is approximately 64,724 cu-ft ((0.95 \* 109,736) – 39,525). The total volume being detained/retained is 66,799 cu-ft which is greater than the mitigation volume needed. As a result, the mitigation volume has been contained by the proposed BMPs. Since the mitigation volume has been met, it is physically impossible for the project to avoid increasing the time of concentration and reducing peak runoff by more than five percent of pre-development conditions (see Section 5.6.1 of the Technical Guidance Document for more information).

## Form 4.2-3 HCOC Assessment for Runoff Volume

Compute weighted curve number for pre and post developed conditions	Pre-developed DA <i>Add more columns if more than 4 DMA</i>			Post-developed DA <i>Add more columns if more than 4 DMA</i>		
	DMA A	DMA B	DMA C	DMA A	DMA B	
<sup>1</sup> Land Cover type	Open Brush (fair cover)	Barren	Impervious Cover	Roof, Asphalt & Concrete	Urban Cover Comm. Landscape	
<sup>2</sup> Hydrologic Soil Group (HSG)	B	B	B	B	B	
<sup>3</sup> DMA Area, ft <sup>2</sup> <i>sum of areas of DMA should equal area of DA</i>	307,098	268,584	12,814	559,071	29,425	
<sup>4</sup> Curve Number (CN) <i>Use Items 1 and 2 to select the appropriate CN from Appendix C-2 of the TGD for WQMP</i>	66	86	98	98	56	
	<sup>5</sup> Pre-Developed area-weighted CN: 76			<sup>6</sup> Post-Developed area-weighted CN: 96		
	<sup>7</sup> Pre-developed soil storage capacity, S (in): 3.16 <i>S = (1000 / Item 5) - 10</i>			<sup>8</sup> Post-developed soil storage capacity, S (in): 0.42 <i>S = (1000 / Item 6) - 10</i>		
	<sup>9</sup> Initial abstraction, I <sub>a</sub> (in): 0.63 <i>I<sub>a</sub> = 0.2 * Item 7</i>			<sup>10</sup> Initial abstraction, I <sub>a</sub> (in): 0.08 <i>I<sub>a</sub> = 0.2 * Item 8</i>		
<sup>11</sup> Precipitation for 2 yr, 24 hr storm (in): 2.68 <i>Go to: <a href="http://hdsc.nws.noaa.gov/hdsc/pfds/sa/sca_pfds.html">http://hdsc.nws.noaa.gov/hdsc/pfds/sa/sca_pfds.html</a></i>						
<sup>12</sup> Pre-developed Volume (ft <sup>3</sup> ): 39,525 <i>V<sub>pre</sub> = (1 / 12) * (Item sum of Item 3) * [(Item 11 - Item 9)^2 / ((Item 11 - Item 9 + Item 7))]</i>						
<sup>13</sup> Post-developed Volume (ft <sup>3</sup> ): 109,736 <i>V<sub>pre</sub> = (1 / 12) * (Item sum of Item 3) * [(Item 11 - Item 10)^2 / ((Item 11 - Item 10 + Item 8))]</i>						
<sup>14</sup> Volume Reduction needed to meet HCOC Requirement, (ft <sup>3</sup> ): 64,724 <i>V<sub>HCOC</sub> = (Item 13 * 0.95) - Item 12</i>						



**NOAA Atlas 14, Volume 6, Version 2**  
**Location name: Chino, California, USA\***  
**Latitude: 34.0058°, Longitude: -117.7034°**  
**Elevation: m/ft\*\***  
 \* source: ESRI Maps  
 \*\* source: USGS



**POINT PRECIPITATION FREQUENCY ESTIMATES**

Sanja Perica, Sarah Dietz, Sarah Heim, Lillian Hiner, Kazungu Maitaria, Deborah Martin, Sandra Pavlovic, Ishani Roy, Carl TrypaLuk, Dale Unruh, FengJin Yan, Michael Yekta, Tan Zhao, Geoffrey Bonnin, Daniel Brewer, Li-Chuan Chen, Tye Parzybok, John Yarchoan

NOAA, National Weather Service, Silver Spring, Maryland

[PF tabular](#) | [PF graphical](#) | [Maps & aerials](#)

**PF tabular**

<b>PDS-based point precipitation frequency estimates with 90% confidence intervals (in inches)<sup>1</sup></b>										
Duration	Average recurrence interval (years)									
	1	2	5	10	25	50	100	200	500	1000
5-min	0.117 (0.098-0.141)	0.152 (0.127-0.184)	0.200 (0.166-0.243)	0.240 (0.198-0.294)	0.296 (0.235-0.375)	0.340 (0.265-0.441)	0.386 (0.293-0.513)	0.434 (0.320-0.595)	0.502 (0.354-0.718)	0.596 (0.406-0.885)
10-min	0.167 (0.140-0.202)	0.218 (0.182-0.264)	0.287 (0.238-0.348)	0.344 (0.284-0.421)	0.424 (0.337-0.537)	0.487 (0.379-0.631)	0.553 (0.420-0.735)	0.622 (0.459-0.852)	0.719 (0.508-1.03)	0.855 (0.582-1.27)
15-min	0.202 (0.169-0.245)	0.264 (0.220-0.320)	0.347 (0.288-0.421)	0.416 (0.343-0.509)	0.512 (0.408-0.650)	0.589 (0.459-0.764)	0.668 (0.507-0.889)	0.752 (0.555-1.03)	0.870 (0.614-1.24)	1.03 (0.704-1.53)
30-min	0.304 (0.254-0.367)	0.396 (0.330-0.479)	0.520 (0.432-0.631)	0.623 (0.514-0.764)	0.768 (0.612-0.975)	0.883 (0.688-1.15)	1.00 (0.761-1.33)	1.13 (0.832-1.55)	1.30 (0.920-1.87)	1.55 (1.06-2.30)
60-min	0.456 (0.381-0.551)	0.594 (0.495-0.719)	0.780 (0.649-0.947)	0.935 (0.771-1.15)	1.15 (0.918-1.46)	1.33 (1.03-1.72)	1.50 (1.14-2.00)	1.69 (1.25-2.32)	1.96 (1.38-2.80)	2.33 (1.58-3.45)
2-hr	0.686 (0.573-0.830)	0.896 (0.747-1.09)	1.17 (0.969-1.42)	1.38 (1.14-1.69)	1.67 (1.33-2.12)	1.88 (1.47-2.44)	2.10 (1.60-2.80)	2.32 (1.71-3.18)	2.61 (1.84-3.74)	2.84 (1.93-4.21)
3-hr	0.872 (0.729-1.06)	1.14 (0.949-1.38)	1.47 (1.23-1.79)	1.74 (1.43-2.13)	2.09 (1.66-2.65)	2.35 (1.83-3.04)	2.60 (1.98-3.46)	2.86 (2.11-3.92)	3.20 (2.26-4.57)	3.45 (2.35-5.12)
6-hr	1.21 (1.01-1.46)	1.57 (1.31-1.90)	2.03 (1.68-2.46)	2.38 (1.96-2.92)	2.84 (2.26-3.61)	3.18 (2.48-4.13)	3.52 (2.67-4.68)	3.85 (2.84-5.27)	4.28 (3.02-6.12)	4.60 (3.13-6.82)
12-hr	1.59 (1.33-1.92)	2.06 (1.72-2.50)	2.67 (2.22-3.24)	3.15 (2.60-3.86)	3.79 (3.01-4.80)	4.26 (3.32-5.52)	4.73 (3.59-6.29)	5.20 (3.83-7.12)	5.82 (4.11-8.33)	6.29 (4.28-9.33)
24-hr	2.05 (1.81-2.36)	2.68 (2.37-3.09)	3.51 (3.09-4.06)	4.18 (3.65-4.88)	5.09 (4.31-6.13)	5.79 (4.80-7.12)	6.50 (5.26-8.19)	7.23 (5.70-9.36)	8.22 (6.22-11.1)	8.99 (6.57-12.5)
2-day	2.47 (2.19-2.85)	3.30 (2.91-3.81)	4.41 (3.89-5.11)	5.34 (4.67-6.23)	6.65 (5.63-8.01)	7.68 (6.37-9.45)	8.76 (7.09-11.0)	9.90 (7.80-12.8)	11.5 (8.69-15.5)	12.8 (9.33-17.8)
3-day	2.66 (2.35-3.07)	3.60 (3.18-4.15)	4.88 (4.30-5.65)	5.96 (5.21-6.96)	7.50 (6.35-9.04)	8.73 (7.24-10.7)	10.0 (8.12-12.6)	11.4 (9.00-14.8)	13.4 (10.1-18.0)	15.0 (10.9-20.9)
4-day	2.89 (2.55-3.33)	3.93 (3.48-4.54)	5.36 (4.72-6.21)	6.57 (5.74-7.66)	8.27 (7.00-9.97)	9.63 (7.98-11.8)	11.1 (8.95-13.9)	12.6 (9.91-16.3)	14.7 (11.1-19.9)	16.4 (12.0-22.9)
7-day	3.28 (2.91-3.79)	4.49 (3.97-5.18)	6.10 (5.37-7.06)	7.43 (6.50-8.67)	9.27 (7.85-11.2)	10.7 (8.89-13.2)	12.2 (9.88-15.4)	13.8 (10.8-17.8)	15.9 (12.0-21.5)	17.6 (12.9-24.6)
10-day	3.60 (3.19-4.15)	4.93 (4.36-5.69)	6.69 (5.89-7.74)	8.12 (7.11-9.48)	10.1 (8.54-12.2)	11.6 (9.63-14.3)	13.2 (10.7-16.6)	14.8 (11.7-19.2)	17.0 (12.9-22.9)	18.7 (13.7-26.1)
20-day	4.36 (3.86-5.03)	6.04 (5.34-6.98)	8.26 (7.28-9.56)	10.1 (8.81-11.8)	12.6 (10.6-15.1)	14.5 (12.0-17.8)	16.4 (13.3-20.7)	18.5 (14.6-23.9)	21.2 (16.1-28.7)	23.4 (17.1-32.7)
30-day	5.23 (4.63-6.03)	7.28 (6.43-8.40)	10.0 (8.83-11.6)	12.3 (10.7-14.3)	15.5 (13.1-18.6)	17.9 (14.9-22.1)	20.5 (16.6-25.8)	23.2 (18.3-30.1)	26.9 (20.4-36.4)	29.9 (21.9-41.7)
45-day	6.19 (5.48-7.14)	8.60 (7.60-9.93)	11.9 (10.5-13.8)	14.7 (12.9-17.2)	18.7 (15.9-22.6)	22.0 (18.2-27.0)	25.4 (20.6-32.0)	29.1 (22.9-37.7)	34.3 (26.0-46.3)	38.6 (28.2-53.8)
60-day	7.12 (6.30-8.20)	9.80 (8.66-11.3)	13.6 (12.0-15.7)	16.9 (14.8-19.7)	21.7 (18.4-26.2)	25.7 (21.3-31.7)	30.1 (24.3-37.9)	34.8 (27.4-45.1)	41.7 (31.5-56.2)	47.4 (34.7-66.2)

<sup>1</sup> Precipitation frequency (PF) estimates in this table are based on frequency analysis of partial duration series (PDS). Numbers in parenthesis are PF estimates at lower and upper bounds of the 90% confidence interval. The probability that precipitation frequency estimates (for a given duration and average recurrence interval) will be greater than the upper bound (or less than the lower bound) is 5%. Estimates at upper bounds are not checked against probable maximum precipitation (PMP) estimates and may be higher than currently valid PMP values. Please refer to NOAA Atlas 14 document for more information.

[Back to Top](#)

**PF graphical**

PDS-based depth-duration-frequency (DDF) curves  
 Latitude: 34.0058°, Longitude: -117.7034°

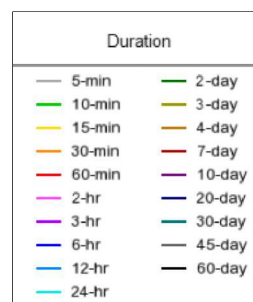
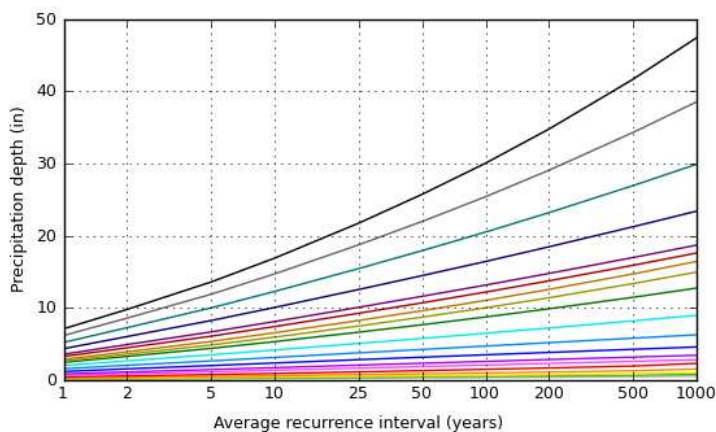
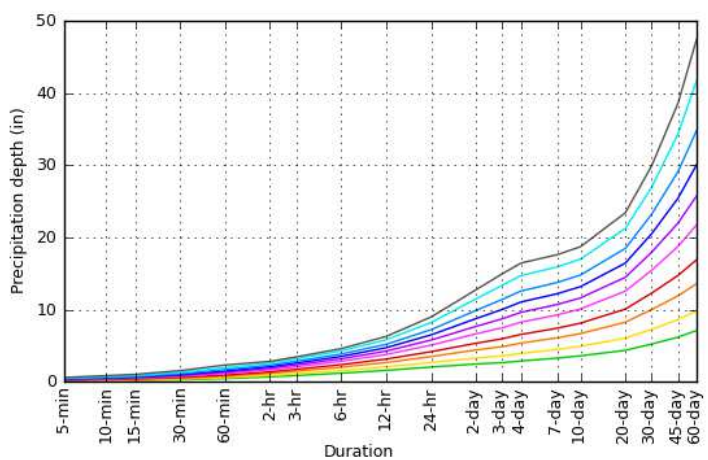

NOAA Atlas 14, Volume 6, Version 2

Created (GMT): Mon Mar 6 21:51:25 2023

[Back to Top](#)

Maps & aerials

Small scale terrain



Large scale terrain



### Large scale map



### Large scale aerial



[Back to Top](#)

---

[US Department of Commerce](#)  
[National Oceanic and Atmospheric Administration](#)  
[National Weather Service](#)  
[National Water Center](#)  
1325 East West Highway  
Silver Spring, MD 20910  
Questions?: [HDSC.Questions@noaa.gov](mailto:HDSC.Questions@noaa.gov)

[Disclaimer](#)

**Curve (I) Numbers of Hydrologic Soil-Cover Complexes For Pervious Areas-AMC II**

Cover Type (3)	Quality of Cover (2)	Soil Group			
		A	B	C	D
<b>AGRICULTURAL COVERS (Continued)</b>					
Legumes, Close Seeded (Alfalfa, sweetclover, timothy, etc.)	Poor	66	77	85	89
	Good	58	72	81	85
Orchards, Evergreen (Citrus, avocados, etc.)	Poor	57	73	82	86
	Fair	44	65	77	82
	Good	33	58	72	79
Pasture, Dryland (Annual grasses)	Poor	68	79	86	89
	Fair	49	69	79	84
	Good	39	61	74	80
Pasture, Irrigated (Legumes and perennial grass)	Poor	58	74	83	87
	Fair	44	65	77	82
	Good	33	58	72	79
Row Crops (Field crops - tomatoes, sugar beets, etc.)	Poor	72	81	88	91
	Good	67	78	85	89
Small grain (Wheat, oats, barley, etc.)	Poor	65	76	84	88
	Good	63	75	83	87

**Notes:**

1. All curve numbers are for Antecedent Moisture Condition (AMC) II.
2. Quality of cover definitions:  
  
 Poor-Heavily grazed, regularly burned areas, or areas of high burn potential. Less than 50 percent of the ground surface is protected by plant cover or brush and tree canopy.  
  
 Fair-Moderate cover with 50 percent to 75 percent of the ground surface protected.  
  
 Good-Heavy or dense cover with more than 75 percent of the ground surface protected.
3. See Figure C-2 for definition of cover types.

**SAN BERNARDINO COUNTY**  
**HYDROLOGY MANUAL**

**CURVE NUMBERS**  
**FOR**  
**PERVIOUS AREAS**

**Curve (I) Numbers of Hydrologic Soil-Cover Complexes For Pervious Areas-AMC II**

Cover Type (3)	Quality of Cover (2)	Soil Group			
		A	B	C	D
<b><u>NATURAL COVERS -</u></b>					
<b>Barren</b> (Rockland, eroded and graded land)		78	86	91	93
Chaparral, Broadleaf (Manzonita, ceanothus and scrub oak)	Poor	53	70	80	85
	Fair	40	63	75	81
	Good	31	57	71	78
Chaparral, Narrowleaf (Chamise and redshank)	Poor	71	82	88	91
	Fair	55	72	81	86
Grass, Annual or Perennial	Poor	67	78	86	89
	Fair	50	69	79	84
	Good	38	61	74	80
Meadows or Cienegas (Areas with seasonally high water table, principal vegetation is sod forming grass)	Poor	63	77	85	88
	Fair	51	70	80	84
	Good	30	58	71	78
Open Brush (Soft wood shrubs - buckwheat, sage, etc.)	Poor	62	76	84	88
	Fair	46	66	77	83
	Good	41	63	75	81
Woodland (Coniferous or broadleaf trees predominate. Canopy density is at least 50 percent)	Poor	45	66	77	83
	Fair	36	60	73	79
	Good	25	55	70	77
Woodland, Grass (Coniferous or broadleaf trees with canopy density from 20 to 50 percent)	Poor	57	73	82	86
	Fair	44	65	77	82
	Good	33	58	72	79
<b><u>URBAN COVERS -</u></b>					
Residential or Commercial Landscaping (Lawn, shrubs, etc.)	Good	32	56	69	75
Turf (Irrigated and mowed grass)	Poor	58	74	83	87
	Fair	44	65	77	82
	Good	33	58	72	79
<b><u>AGRICULTURAL COVERS -</u></b>					
Fallow (Land plowed but not tilled or seeded)		77	86	91	94

FOR  
EXISTING  
CONDITIONS

FOR  
EXISTING  
CONDITIONS

FOR  
PROPOSED  
CONDITIONS

**SAN BERNARDINO COUNTY**  
**HYDROLOGY MANUAL**

**CURVE NUMBERS  
FOR  
PERVIOUS AREAS**